

WORKSHOP MANUAL | MANUEL D'ATELIER | MANUAL DETALLER

| 250 SE FACTORY
| 300 SE FACTORY



SHERCO

TABLE OF CONTENTS

FORWARD	3
TOOLS LIST 250-300 SE	4
TECHNICAL SPECIFICATION	5
ENGINE	5
CARBURETTOR.....	5
BIKE SPECIFICATION	6
STANDARD ADJUSTMENT	7
FORK	7
SHOCK ABSORBER	7
OPERATIONS REQUIRING DEMOUNTING OR NOT ENGINE	8
REMOVING / REINSTALLING THE ENGINE	9
REMOVING THE ENGINE	9
REINSTALLING THE ENGINE	9
ENGINE DISASSEMBLY	10
» Draining the gearbox	10
» Removing the pinion and gear selector lever	10
» Dismantling the engine top end :	11
» Removing the cylinder head, cylinder and piston ...	11
» Disassembly of the right side:	13
» Removal of the clutch cover	13
» Removal of the clutch unit	13
» Disassembly of the left side :	16
» Removing the starter assembly	16
» Ignition removal	17
» Disassembly of the crankcases:	18
» Inlet pipe and reed valve box	18
» Separation of the half housing	18
» Removal of the gear selection	19
» Removal of the crankshaft	20
REPLACING ENGINE COMPONENTS	21
» Replacement of the crankshaft bearings	21
» Gear box output bearing	22
» Water pump / balnce shaft bearing	43
INSPECTING THE ENGINE COMPONENTS	23
» Checking the crankshaft:	23
» Balancing mass, External dimension control	23
» Radial clearance of the connecting rod head	23
» Lateral clearance of connecting rod head	23
» Checking the crankshaft runout	24
» Piston and cylinder inspection:	24
» Piston	24
» Checking the end gap	24
» Checking the piston pin	25
» Checking state of the cylinder wear	25
» Disassembly of the valve mechanism	25
» Functional check	27
» Assembling the valve mechanism	28
» Transmission control	30
» Clutch	30
» Gearbox	31
ENGINE REASSEMBLY	32
» Assembling the crankshaft and the gearbox	32

» Assembly the ignition and starter assembly	33
» Gear selection mechanism	34
» Primary transmission and clutch	35
» Clutch housing	37
» Installing the electric starter	37
» Piston et cylinder	38
» Reed valve and intake pipe	41
» Installation of the ignition cove	42
» Gearbox output pinion and clutch push rod	42

ELECTRICAL PART	45
» Electical components	45
» 1- Fan control	46
» 2- CDI	46
» 3-Checking voltage regulator	46
» 4-Battery check	47
» 5-starter check	47
» 6-Checking the alternator	47
» 7-Checking the (crankshaft) hall sensor	48
» 8-Temperature sensor check	48
» 9-Checking the ignition coil	49
» 10-Checking the valve moto	49

DIAGNOSTIC TOOL SYNERJECT	50
--	----

SYNERJECT INJECTION SYSTEM

PRESENTATION	50
1.1- Components Identification	50
1.2- Description Exxodiag diagnostic Tools	50
1.3- Diagnostic tool kit contents	51
1.4- Installation of the diagnostic tool	51
PRESENTATION OF THE SOFTWARE	55
2.1- Connection with keyless system	55
2.2- Software settings	57
2.3- Update menu and synchronization	58
3 - Use of the software	60
3.1 Identification	60
3.2 Reading trouble codes	61
3.3 Erasing fault codes	63
3.4 Actuator test	64
3.5 ECU update	66
3.6 Print screen function	68

TIGHTENING TORQUES	69
---------------------------------	----

CARBURETOR TUNING	72
» SE 250-Tableau réglage carburation	72
» SE 300-Tableau réglage carburation	73

WIRING DIAGRAM	74
» Main harness (Ref: 7107)	74
» Homologated light diagram (Ref: 8145)	75
» Racing light diagram (Ref: 6845)	76

This manual is designed primarily for skilled mechanics working in a properly equipped workshop. The execution of the operations in this manual requires a strong mechanical knowledge and specific SHERCO tools designed for the 250 SE and 300 SE engine.

This workshop manual is a supplement to the SHERCO 250 SE and 300 SE owner's manual.



TOOLS LIST 250-300 SE

TOOLS 250/300 2T

Owner Manual
10666



Clutch Tool
5749

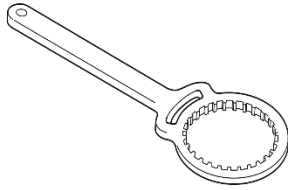

Engine support / Container
R481/R455

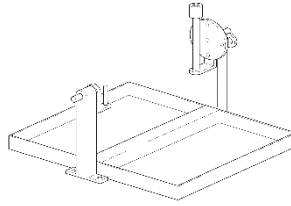

Ring Extractor
R464

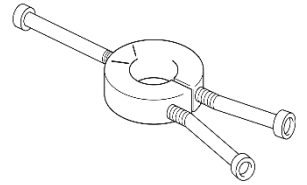

Pinion clutch shaft tool
5593

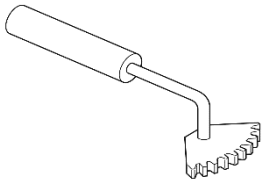

Ignition Tool
4753

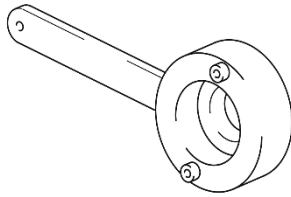

Flying extractor
R462

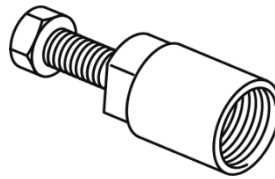

Tool kit
0726

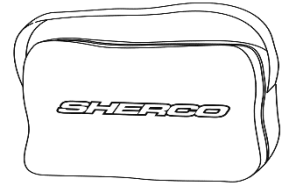

Diagnostic Tool
8561



SUSPENSION

FACTORY

Inner tube clamp
7670

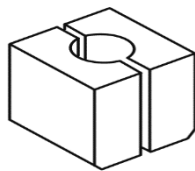

Top cap wrench
7666

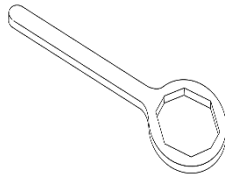

Oil seal insert
7668

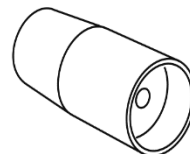

Seal hammer
7669

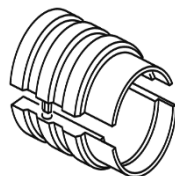

Piston rod holder
7667

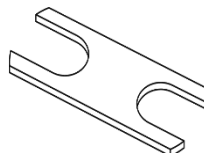

Oil measuring cup
7671

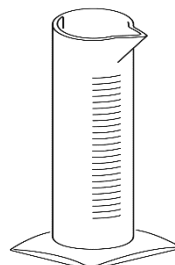

TECHNICAL SPECIFICATION

ENGINE

	250	300
Type	Mono-cylinder 2 temps liquid	
Displacement	249,32 CC	293,14 CC
Bore / Stroke	66,4 / 72 mm	72 / 72 mm
Compression ratio	11.5 / 1	11.9 / 1
Fuel	Without lead 95 or 98 mixed with 2 stroke oil (2%)	
Cooling	Liquid forced	
Ignition system	Electronic ignition Synerject	
Spark plug	NGK BR7ES	
Spark plug electrode distance	0.7 mm	
Piston	Aluminium graphite treated	
Gear box oil	750 ml SAE 5W40	
Primary reduction ratio	27 : 75	
Gearbox :	6 Speeds	
1 st	14 : 32	
2 nd	15 : 26	
3 rd	18 : 25	
4 th	22 : 24	
5 th	24 : 22	
6 th	25 : 20	
Final transmission	13 X 50	13 X 48
Clutch	Multi-disk in oil, Hydraulic command	
Start-up	Electric starter	
Battery	BS BSLi-02 Lithium 12V 2Ah	
Alternator	220W	

CARBURETTOR

	250	300
Carburettor type	KEIHIN PWK 36S AG	KEIHIN PWK 36S AG
Needle position	3 rd position from the top	3 rd position from the top
Needle jet	N1EG (N84K)	N8RE (N84K)
Main jet	KEA 162 (KEA 115)	KEA 165 (KEA 115)
Pilot jet	KEP 40 (KEA38)	KEP 40 (KEA 38)
Starter jet	85 (50)	85 (50)
Air screw adjustment	1T ¼	1T ½
Slide shape	N°7	N°7



TECHNICAL SPECIFICATION

BIKE SPECIFICATION

Frame	Semi-perimétric CrMo steel with aluminium sub frame
Fork	KAYABA USD Ø48mm Closed cartridge (FACTORY)
Rear shock	KAYABA rear shock with separate cylinder Aluminium swing arm
Travel front / rear	FACTORY 330/330mm
Front brake	Rotor Ø 260mm
Rear brake	Rotor Ø 220mm
Brake disc	Limit : Front 2.7mm et Rear 3.6mm
Front tyre	90/90-21"
Rear tyre	140/80-18"
Off road tyre pressure F / R	0.9 bar
Fuel tank capacity	10.4L with 1 liter de reserve
Angle of the steering column	27.3°
Wheel base	1480 mm

STANDARD ADJUSTMENT

FORK

Setting Factory – Fork KAYABA USD Ø48 mm (Closed cartridge)

Compression	Comfort	20 clicks back
	Standard	13 clicks back
	Sport	8 clicks back
Rebound	Comfort	18 clicks back
	Standard	13 clicks back
	Sport	10 clicks back
Spring stiffness	Rider weight : 65-75 kg	4.0N/mm (Original)
	Rider weight : 75-85 kg	4.2N/m
	Rider weight : 85-95 kg	4.4N/m
Fork oil	01M	345 CC

SHOCK ABSORBER

Setting Factory – Shock absorber KAYABA

Low-speed compression	Comfort	20 clicks back
	Standard	14 clicks back
	Sport	12 clicks back
High-speed compression	Comfort	2,5 turns back
	Standard	1.5 turns back
	Sport	1 turn back
Rebound	Comfort	15 clicks back
	Standard	13 clicks back
	Sport	11 clicks back
Spring stiffness	Rider weight : 65 - 75 kg	46N/mm
	Rider weight : 75 - 85 kg	48N/mm (original)
	Rider weight : 85 - 95 kg	50N/mm
Oil type		K2C



OPERATIONS REQUIRING DEMOUNTING OR NOT ENGINE

	REMOVING THE ENGINE	NOT DEMOUNTING ENGINE
Crankshaft (including connecting rod kit)	•	
Gear box	•	
Crankshaft bearing	•	
Gear box bearing	•	
Piston		•
Cylinder		•
Cylinder head		•
Ignition		•
Pinion of ignition system		•
Clutch		•
Water pump / balancer shaft		•
Gear selection		•

REMOVING / REINSTALLING THE ENGINE

REMOVING THE ENGINE

WARNING

To remove the engine, you must remove the swing arm axle, the swing arm and the rear wheel. To keep the bike from falling, remember to support the chassis with an appropriate jack.

- Drain (Cf. Owner's manual)
 - Engine oil.
 - Coolant.
- Remove the seat.
- Disconnect the battery.
- Remove the fuel tank and radiator side panels.
- Disconnect all the electrical wiring connectors from the engine (Starter, Spark plug cap, actuator).
- Remove the exhaust.
- Remove the coil.
- Remove the carburettor.
- Remove the chain.
- Remove the chain guard.
- Remove the clutch-actuating cylinder.

WARNING

When the clutch receiver has been removed, the piston is loose. Hold the piston in place using a plastic strap.

- Remove the water hoses connected to the engine.
- Remove the left side radiator.
- Loosen all the engine bolts.
- Loosen the swing arm axle.
- Remove the engine support and the electric motor.
- Remove the engine axle.
- Remove the swing arm axle.
- Remove the engine from the frame.

REINSTALLING THE ENGINE

The motor should be installed in the frame in the reverse order of how it has been removed. The following torque values should be used.

Tightening torques:

Engine bolts: 60Nm

Swing arm axle nut: 100 Nm

Clutch receiver screws: 10 Nm

Cylinder head bracket bolts 23Nm

Exhaust mounting bolts: 10Nm



» Draining the gearbox

- Remove drain plugs **1** & **2**, and allow the oil to drain.

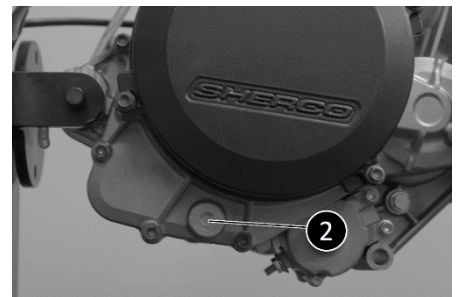
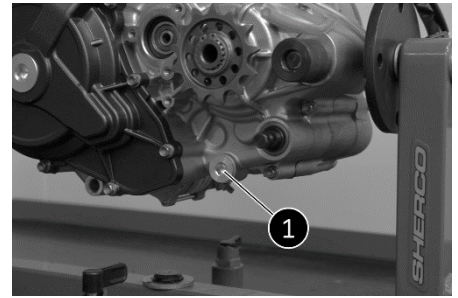

» Removing the pinion and gear selector lever

- Remove circlips **1** using external pliers.
- Remove the gearbox sprocket **2**.
- Remove screw **3** and remove the gear selector lever.
- Pull out the clutch control rod **4**.

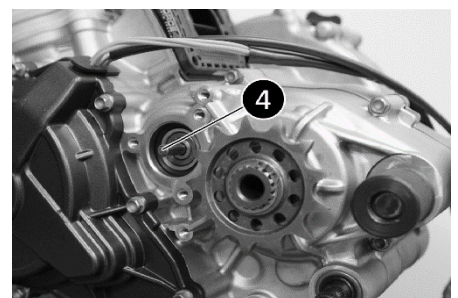
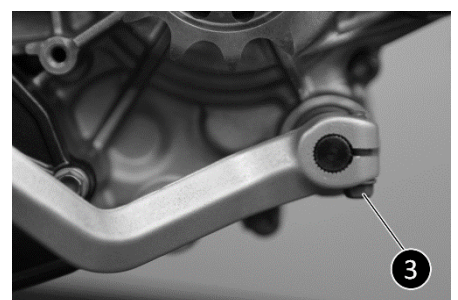
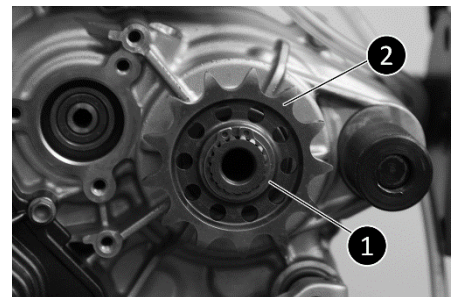

» Dismantling the engine top end :

» Removing the cylinder head, cylinder and piston

- Remove the shoulder screws **1** and the cooper washers.

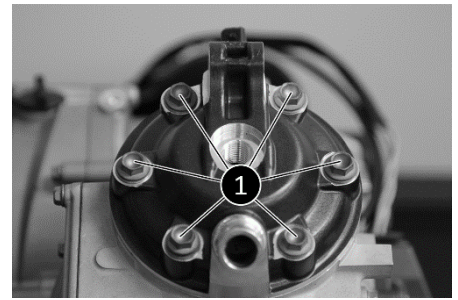

- Remove the cylinder head and the two toric seals.

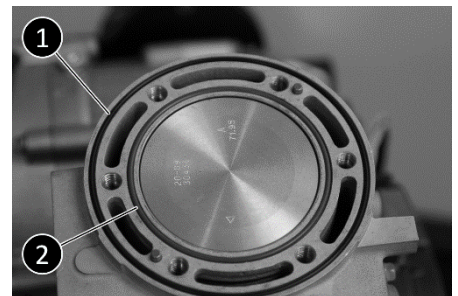

- Remove the 3 valve actuator cover screws taking care to not lose the metal spacers **1**.

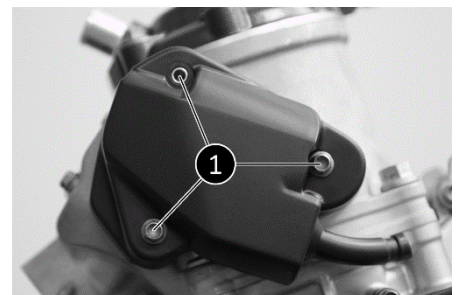

- Remove the exhaust valve actuator **2**.

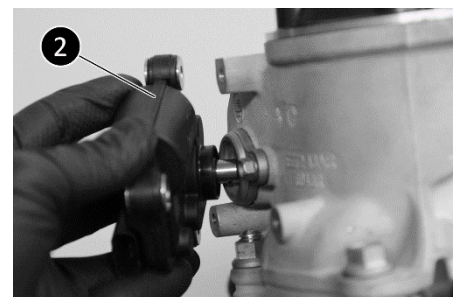

- Remove the exhaust chamber cover **3**.



ENGINE DISASSEMBLY

- Remove the 4 shoulder nuts **4** at the base of the cylinder.

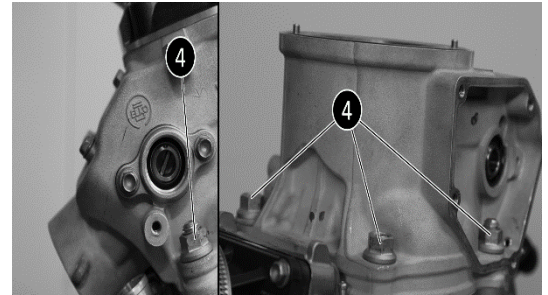

- Remove the cylinder and place tool 5774 **5** under the piston to hold it in place.
- Cover the housing.

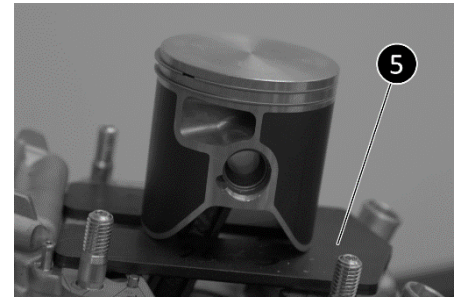

- Remove the piston pin circlips **6**.

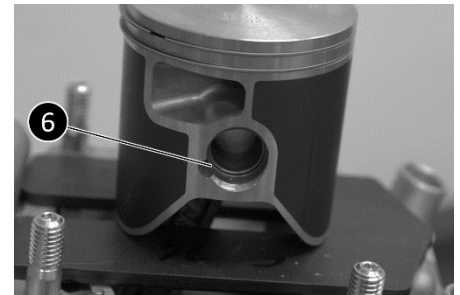

- Remove the piston pin **7**.



- Remove the piston, remove the needle bearing **8**.
- Remove the tool 5774 **9**.
- Remove the base gasket **10**.

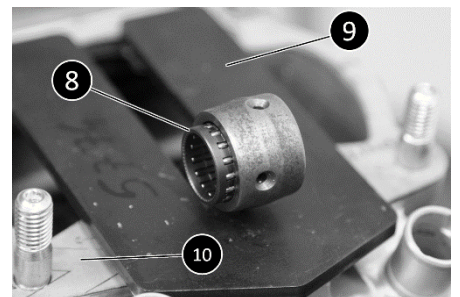

›| Disassembly of the right side:

›| Removal of the clutch cover.

- Remove the 4 screws **1**.
- Remove the water pump housing **2** and its O-ring.
- Remove the water pump impeller **3** by turning it counter clockwise.
- Remove the 9 housing screws **4**.
- Using a plastic tipped hammer gently tap the water pump shaft but allow it to stay in place so as to allow dismantling the crankcase.

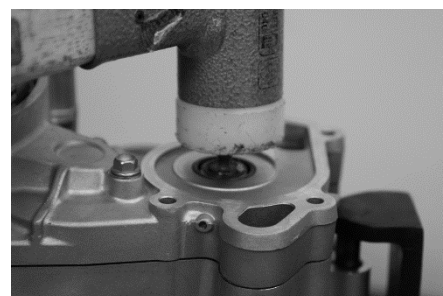
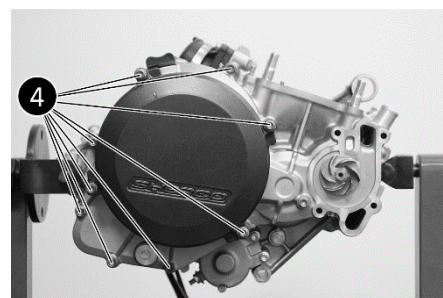
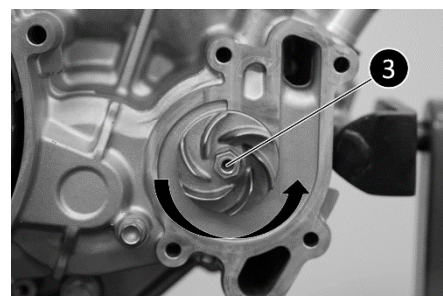
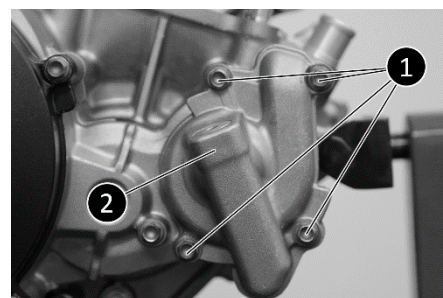

›| Removal of the clutch unit.

- Remove the 6 screws and their springs for the clutch pressure plate **1**,
remove the clutch pressure plate **2**.

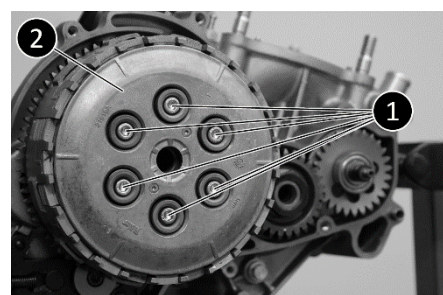

ENGINE DISASSEMBLY

- Remove the clutch release bearing **3**.

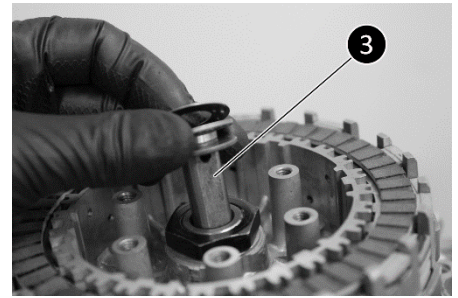

- Remove the friction discs pack and smooth disc from the clutch basket **4**.

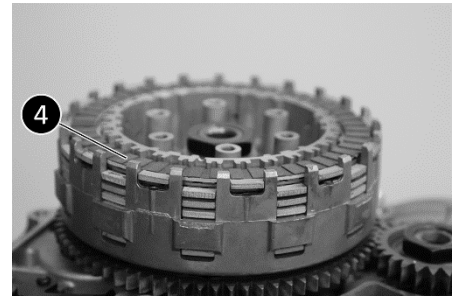

- Using tool 5206 **5** Installed between the crown and the primary transmission gear which locks the assembly allowing the transmission nut to be removed using 28 mm socket.
- Remove the nut and conical washer.



- Using tool 5749 **6** to hold the boss clutch and the clutch basket in place. Loosen the nut using a 30 mm socket.
- Remove the nut and its conical washer; remove tool 5749 and the boss clutch.

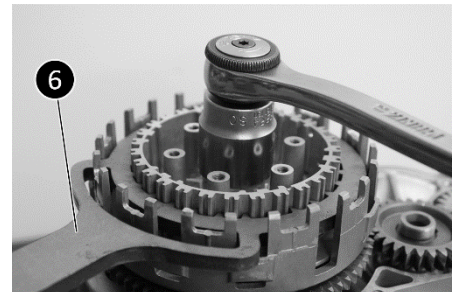

- Remove the support washer from the boss clutch **7**.

- Remove the clutch basket **8**.

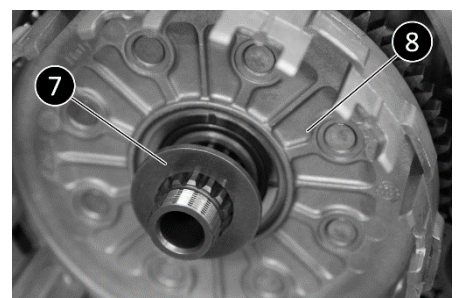

- Remove the needle bearing **9** as well as the spacer **10**.

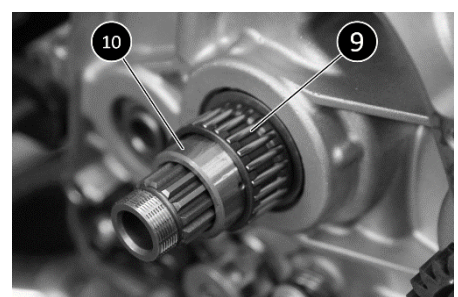

ENGINE DISASSEMBLY

- Using a magnet remove the washer **11** from the bearing support.

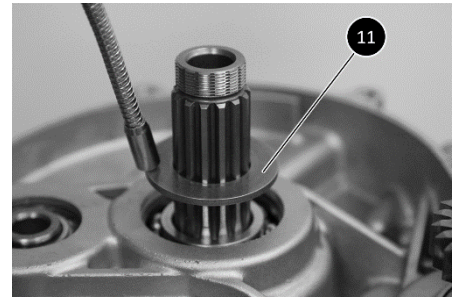

- Remove the pinion and its key from the crankshaft.

The primary transmission pinion and clutch gear ring gear are matched, so they cannot be changed separately. Always replace them as a matched set.

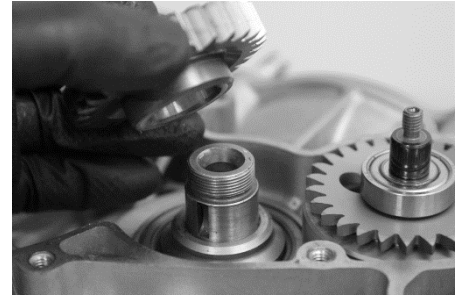

- Remove the water pump / balancer shaft **12**.

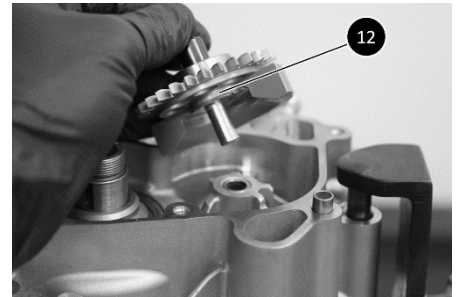

- Using a pair of plier remove the crankshaft tail spacer **13**.

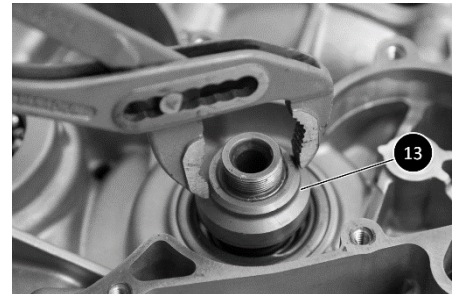

- Push the pawl of the selector mechanism towards the axel in order to be able to remove the selector.

- Remove the BTR screw **14** from the star selector.

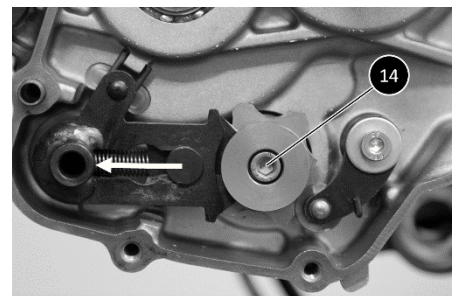

- Using a nose pliers depress the locking finger of the selector. Remove the selector star **15**.

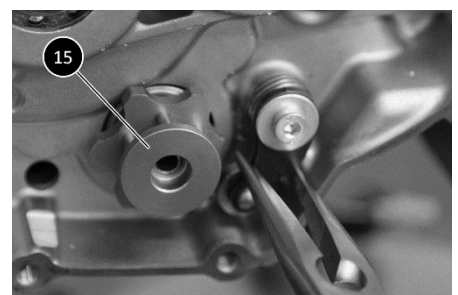

- Remove the pin **16** from the selector cylinder.

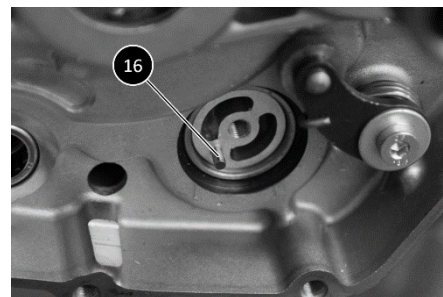

- Remove the BTR screw **17**, remove the washer the locking tab and the spring.

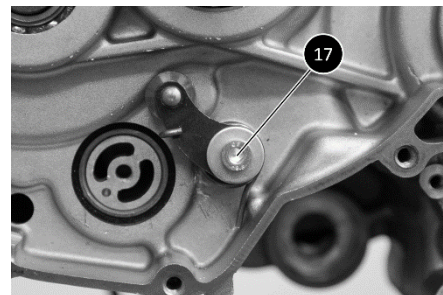

›| Disassembly of the left side :

›| Removing the starter assembly.

- Remove the 8 screws from the ignition cover **1**.

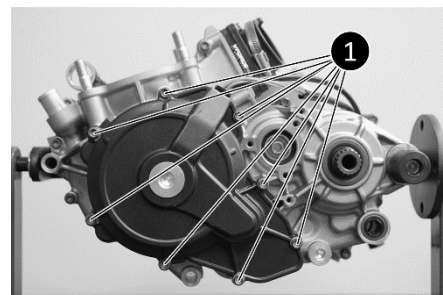

- Remove the 2 screws from the starter **2** and remove the starter **3**.

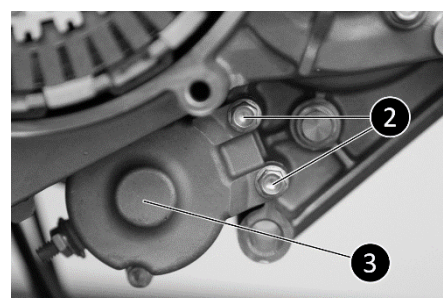

- Remove the 3 screws **4** from the torque limiter mount **5**.

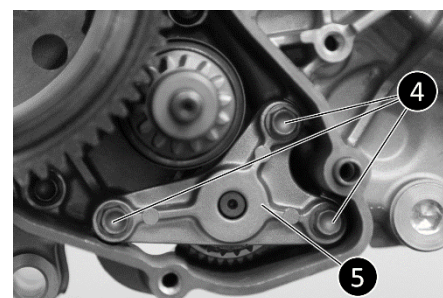

ENGINE DISASSEMBLY

- Remove the starter motor **6**.
Be careful to not lose the washer, which is located behind the launcher.

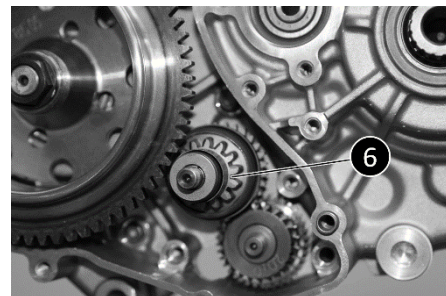

- Remove the torque limiter **7**.

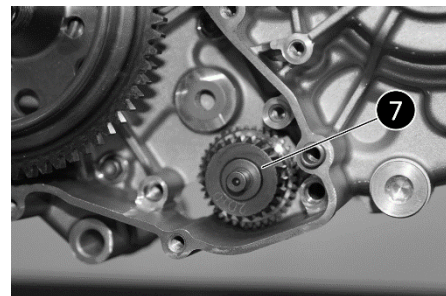

› Ignition removal.

- Hold the ignition flywheel with tool 4753 **1**, remove the locknut from the crankshaft.

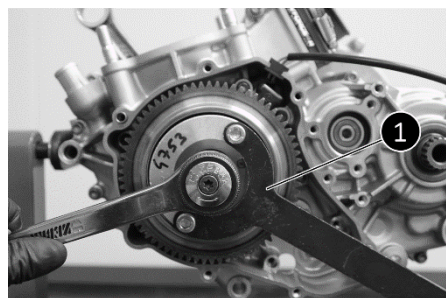

- Place tool 5208 **2** on the thread of the crank and remove the ignition flywheel.

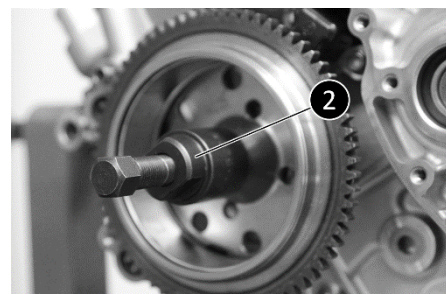

- Remove the ignition key **3**.

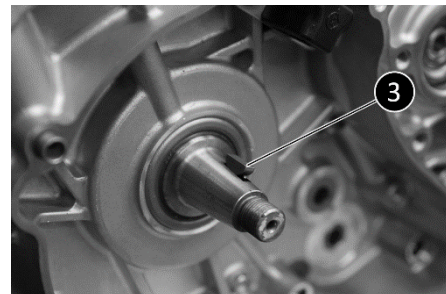

- Remove the two ignition sensor screws **4**, as well as the ignition sensor **5**.

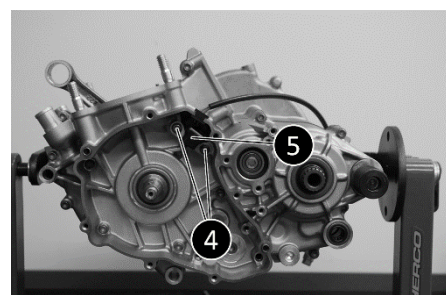

» Disassembly of the crankcases:

» Inlet pipe and reed valve box.

- Remove the 4 retaining screws from the inlet pipe **1**.
- Remove the inlet pipe **2**.

- Remove the reed valve box **3** as well as the seal **4**.

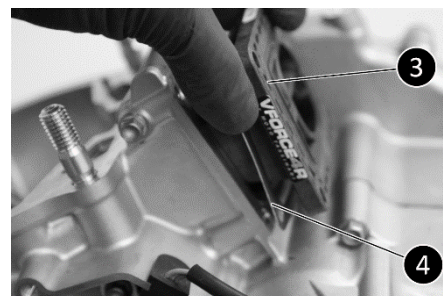
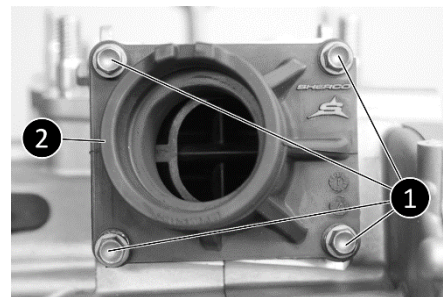

» Separation of the half housing.

- Tilt the engine to have the ignition side facing you.
- Remove the 12 screws **1**.

- **Take care** to remove the screw **2** which is located behind the ignition sensor.

- Using an external circlips tool to remove the clips **3** located on the clutch gearbox shaft.

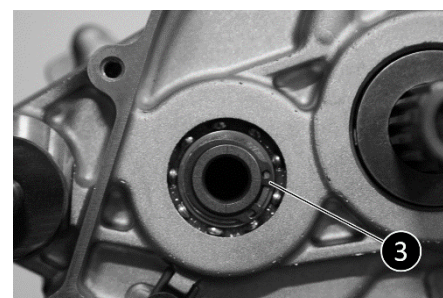
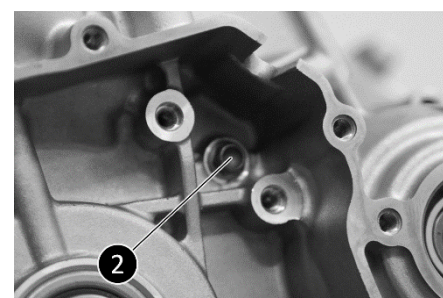
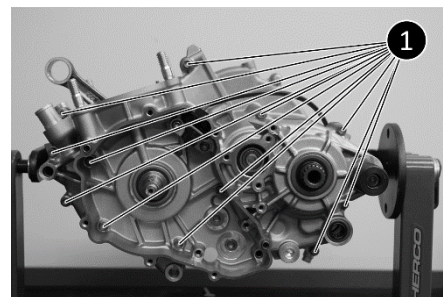

ENGINE DISASSEMBLY

- Remove the left crankcase half by lifting it up and lightly tapping the gearbox output shaft with a plastic hammer in order to separate the two halves.

WARNING

Avoid as much as possible introducing a screwdriver or any other tool between the two-crankcase halves to separate them. You will risk damaging the mating plane.

- Remove the half housing and the central seal **4**.

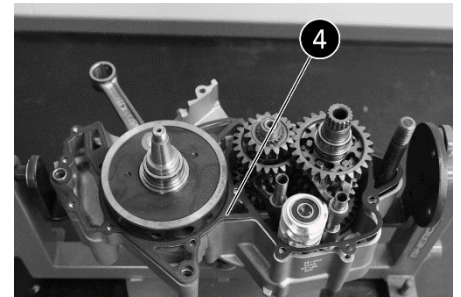

» Removal of the gear selection.

- Remove the gearbox lubrication tube **5**.

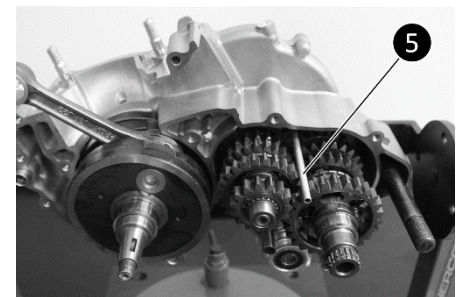

- Remove the two fork pins **6**.

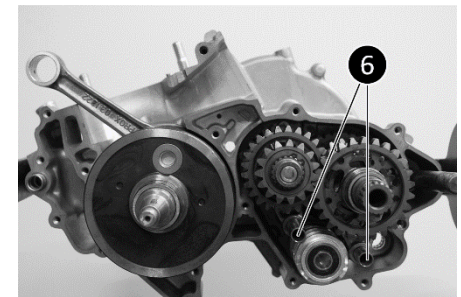

- Push the forks to the side to release them from the drum **7**.

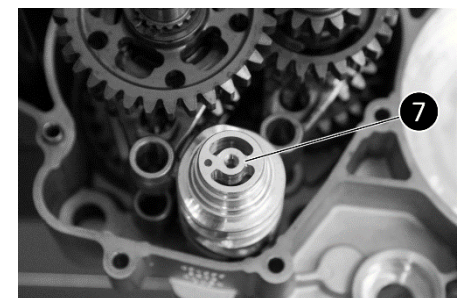

ENGINE DISASSEMBLY

- Take care to not lose the rollers **8** on the shifter fork lugs.

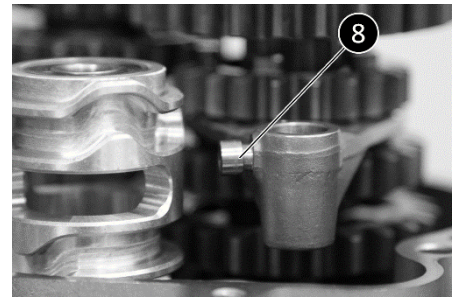

- Remove the shift forks **9** from the gearbox.

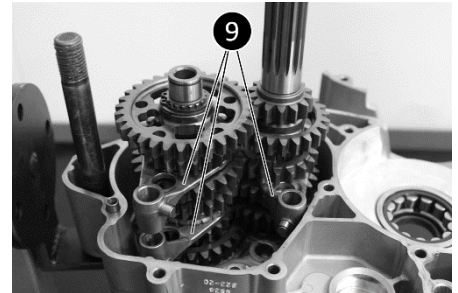

- Simultaneously bring out of their bearing the drive shaft and the shaft secondary.

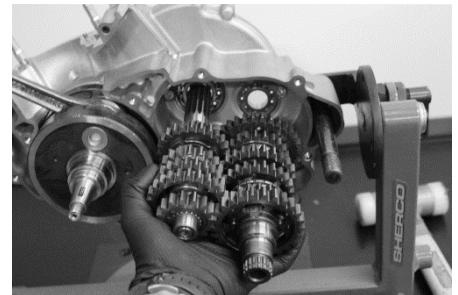

» Removal of the crankshaft.

- Remove the crankshaft assembly from its bearing (you may have to use plastic hammer end lightly tap the end of the crankshaft).

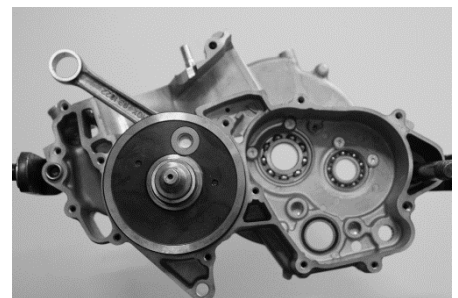

- Remove the O-ring **1**.

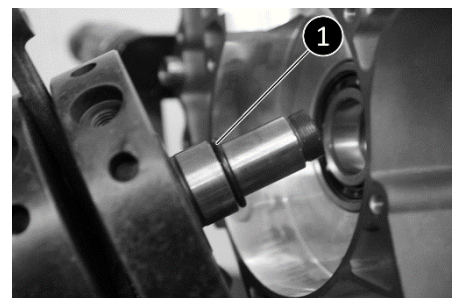

WARNING

When the engine is completely dismantled, it is best to replace all gaskets, oil seal, O-rings and all the bearings.

- Clean all the parts and check everything for wear, replace as required.

REPLACING ENGINE COMPONENTS

» Replacement of the crankshaft bearings.

- Remove the crankshaft oil seal on the left end of the crankshaft.
- Place a kinetic puller of 35 capacity on the roller bearing, heat the crankcase around the bearing and remove the bearing.
- When replacing the bearing it is necessary to replace the inner ring **1** which is located next to the balancing mass.
- Heat tool R464 **2** to approximately 150°C immediately fit into the ring interior. Make sure the tool is installed so that the heat will transfer to the ring. Remove the ring.
- In order to install the new ring use the old ring on the bearing press-fit tool.
- Heat the periphery of the bearing housing, use the installation tool and light pressure to install the new bearing.
- Install a new oil seal.
- To install the new ring reheat the tool to around 150°C. Insert the new ring in the proper location

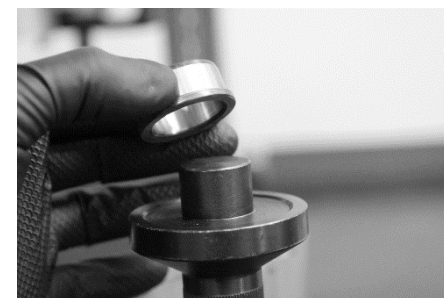
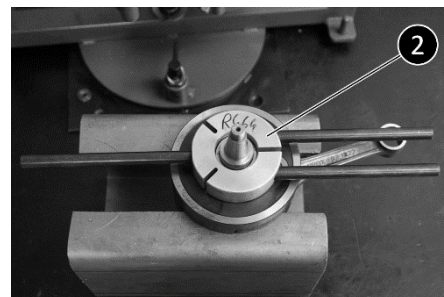
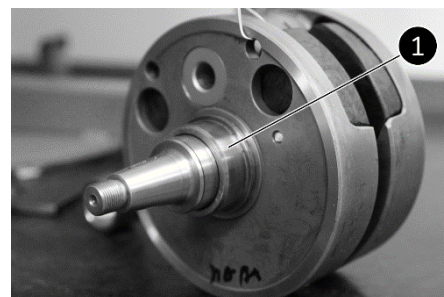
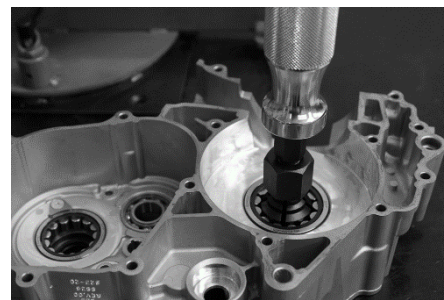

REPLACING ENGINE COMPONENTS

» Gear box output bearing.

- Start by removing the ignition housing ([Cf » Disassembly of the left side](#)).
- Unscrew the bearing locking screw, and remove the retaining plate.
- Install a 30mm kinetic puller in the roller bearing.
- Heat the periphery of the bearing.
- Remove the bearing.
- Heat the ring on the transmission secondary shaft.
- Place a 2-finger puller on secondary shaft and remove the ring.
- use the old ring on the bearing installation tool, heat the periphery of the bearing.
- Install the bearing in its housing using light pressure; make sur it seats in the bottom of the housing.
- Put blue thread lock on the screw and replace the retaining plate, tighten the screw to 5Nm.
- Heat and install the new bearing ring.
- It is recommended that you replace the output shaft seal at this time.

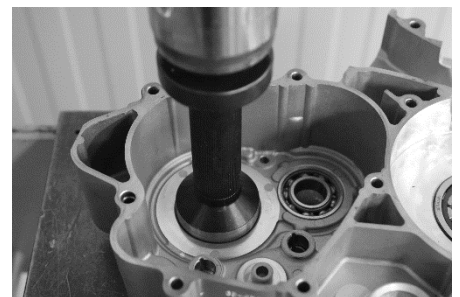
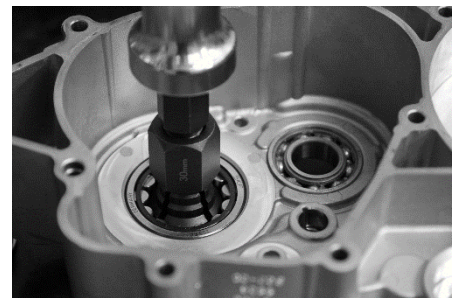
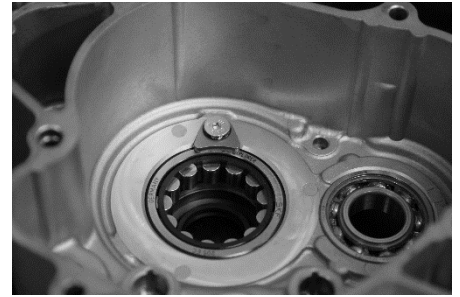

›) Checking the crankshaft:

›) Balancing mass, External dimension control.

- Using a caliper, measure the outer distance of the balancing mass.

External value: 64.3mm +0 / -0.2



›) Radial clearance of the connecting rod head.

- Fit the crankshaft on a set of V-blocks and place a dial indicator **1** against the head of the connecting rod.
- Move the connecting rod head towards the gauge, then in the opposite direction.
- The difference between these two measurements corresponds to the radial clearance.

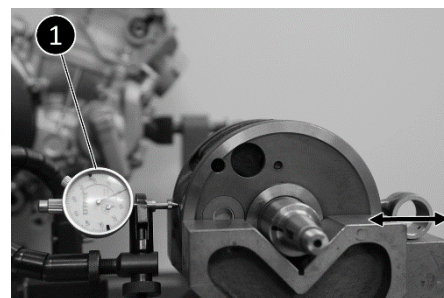

Radial clearance of the connecting rod head:

Standard: 0.015 mm – 0.025 mm

Limit: 0.06 mm

If the radial clearance is greater than the tolerated limit, the crankshaft must be replaced.

›) Lateral clearance of connecting rod head.

- Using a feeler gauges, measure the connecting rod head side play ;

Lateral clearance connecting rod head:

Standard: 0.8 mm - 1 mm

Tolerated limit: 1.25 mm

If the clearance is greater than the tolerated limit, the crankshaft must be replaced.

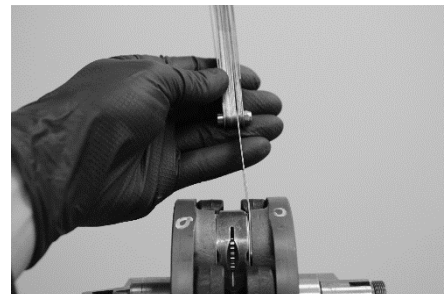

INSPECTING THE ENGINE COMPONENTS

›| Checking the crankshaft runout.

- Place the crankshaft on an alignment device or a set of V-blocks and locate the dial indicators as shown in the picture.
- Then slowly rotate the crankshaft. The maximum difference between the measurements corresponds to the centring of the crankshaft.

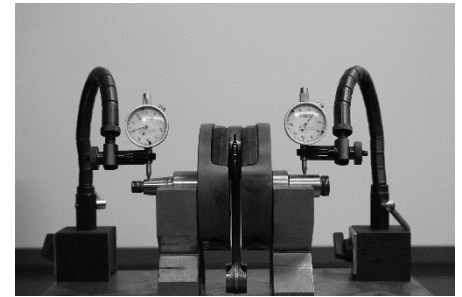

False round:

Standard: 0.03 mm maxi

Tolerated limit: 0.05 mm

›| Piston and cylinder inspection:

›| Piston.

If you want to use a piston that has been in service then you must check the following points:

- Skirt:

Look for any traces metal transfer (scuffing).
Light amount of scuffing can be removed with a soft stone.

- Piston ring grooves:

The piston rings should not get fit tight in the ring groove.

- The piston ring retainers :

They must not be worn or loose.

- Piston rings:

Check condition and end gap.



Ø PISTON		
250	66.36	A
	66.37	B
300	71.96	A
	71.97	B

›| Checking the end gap

- Insert the piston ring into the cylinder and use the piston to locate them at approximately 10 mm below the upper edge of the cylinder.
- Using a feeler gauge measure the end gap.

Gap clearance:

Standard 0.35-0.45mm,

Limit 0.65mm.

If the clearance is greater than what is indicated, it is then necessary to check the condition of the cylinder and the piston. If they are within tolerance then replace the piston

INSPECTING THE ENGINE COMPONENTS

›| Checking the piston pin

Piston pin diameter

Standard: 17,995-17,998 mm

Tolerated limit: 17,962mm

Piston pin hole diameter

Standard: 18.006-18.010mm

Tolerated limit: 18.08mm

›| Checking state of the cylinder wear

- To determine the cylinder wear. Measure the cylinder bore with bore inspection tool. Measure about 10mm from the top edge of the cylinder. Take readings 90 degrees apart to check for the possibility of ovalization.

Cylinder	Cylinder bore	Piston
250	66.410-66.420	A
	66.421-66.430	B
300	72.010-72.020	A
	72.021-72.030	B

›| Disassembly of the valve mechanism .

- Remove the valve cover **1**.
- Remove the screws from the valve actuator cover **2** taking care to not lose the metal spacers.
- Remove the cover
- Remove the actuator valve.

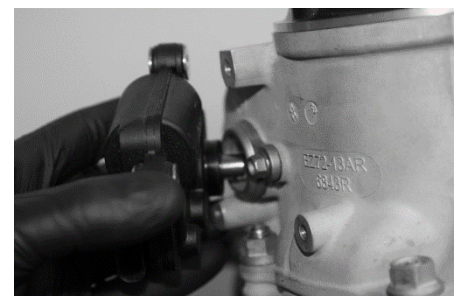
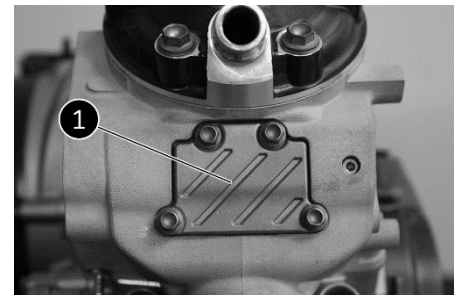

INSPECTING THE ENGINE COMPONENTS

- Remove the 2 screws **3**, remove the actuator support **4**.

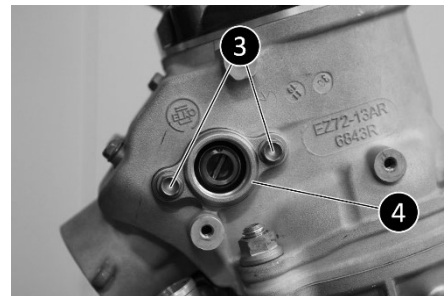

- Remove the 4 screws **5** from the exhaust chamber cover.

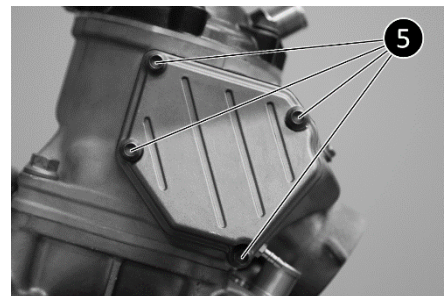

- Degrease the exhaust gas chamber.

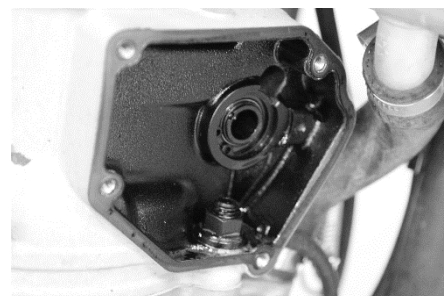

- Make sure that the drain hole **6** is not clogged.

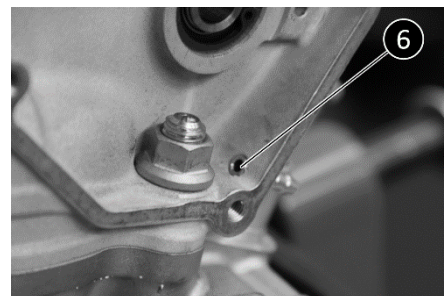

- Remove the stop screw **7** and its copper sealing washer.

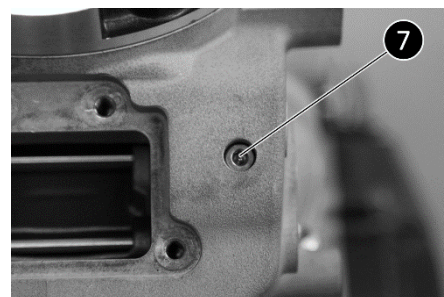

- using inside circlips pliers remove the circlip **8**.

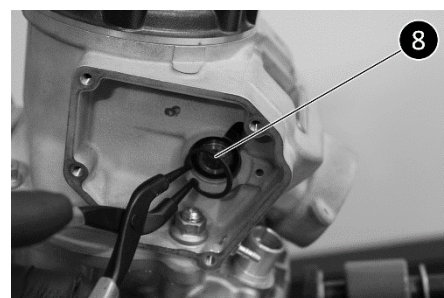

INSPECTING THE ENGINE COMPONENTS

- Use a clamp and remove the booster valve.

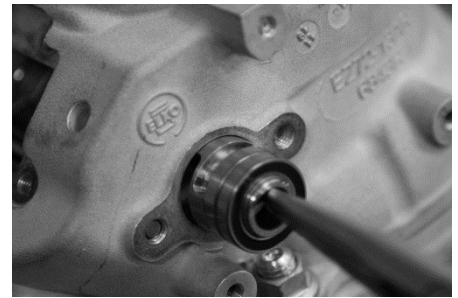

- Using a rod push out the first valve shaft.

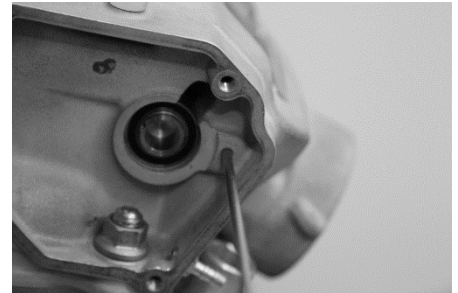

- if it does not come out with the booster, use a pair of pliers to remove the valve axel.



- Remove the valve from the housing.

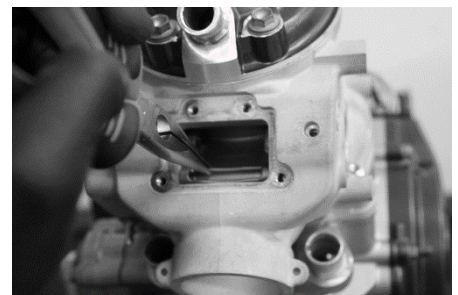

› Functional check.

- Clean and descale all disassembled parts.
- Visually inspect the exhaust barrel and use your fingernail to make sure there are no scratches on the barrels.
- Inspect the exhaust valve axel and replace if there are deep scratches them.
- Check the play in the booster bearings, make sure they rotate freely.



INSPECTING THE ENGINE COMPONENTS

» Assembling the valve mechanism.

Systematically replace all of the top end gasket.

- Place the valve in its housing.
- Install the booster and its circlips in the exhaust chamber.
- Install the first valve shaft.
- Position the second valve shaft, tacking care to make sure it is inserted correctly in the booster.
- Install the second booster into its housing.

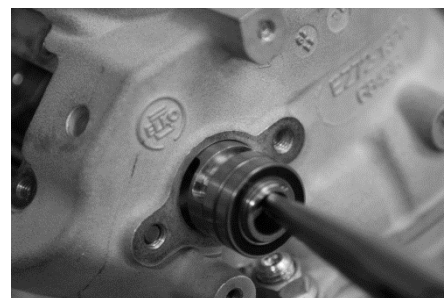
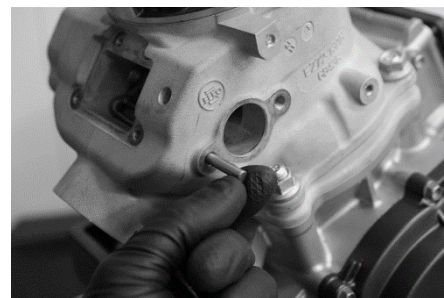
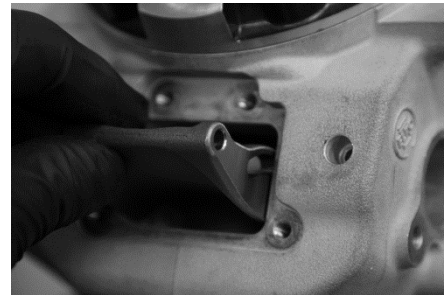

INSPECTING THE ENGINE COMPONENTS

- Tighten the booster stop screw **1** at 4Nm do not forget to install is sealing washer.

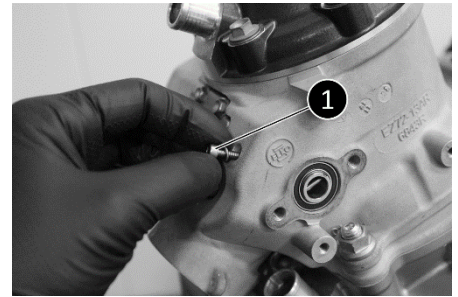

- Use the new gasket and install the actuator support **2**.
- Tighten screws **3** and **4** to 10Nm.

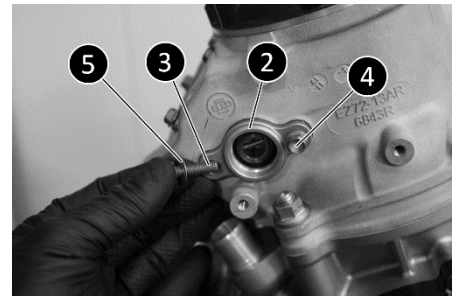

Warning : screw **3** is a 6 x 20 screw use a washer **5** while the screw **4** is a 6 x 16 screw and does not have an attached washer.

- After reassembly, check the side play of the central valve the minimum is 0.1mm.
- Operate the system through is rotational movement.

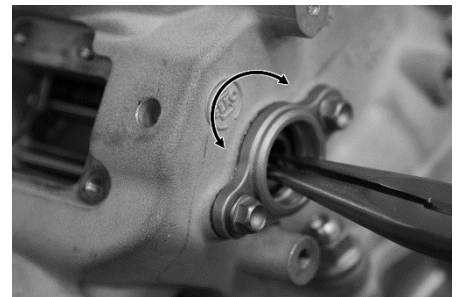

- Check to make sure that the valve opens 100 %.



- Check to make sure the that the valve closes 100 %.

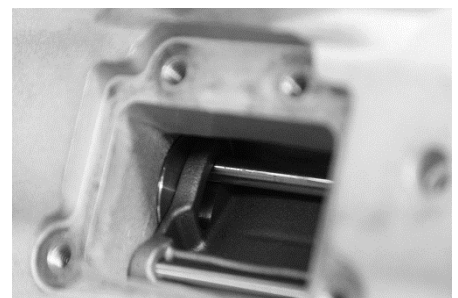

INSPECTING THE ENGINE COMPONENTS

- Install the valve cover along with a new gasket.
- Tighten the 4 screws to 6, 5 Nm.

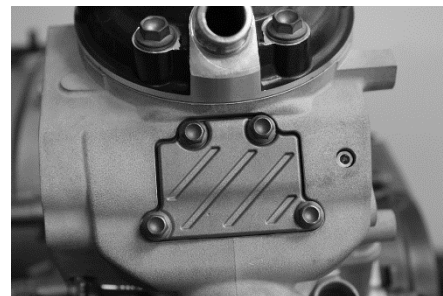

- Install the exhaust chamber cover along with a new gasket and tighten the 4 screws to 10 Nm.

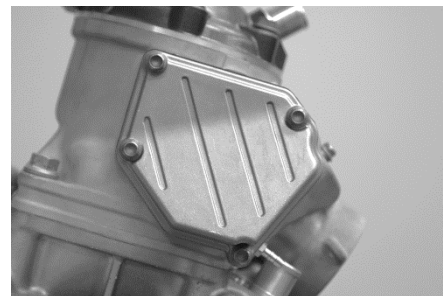

WARNING

After any maintenance, operation on the internal parts of the cylinder and / or after changing the cylinder it is necessary to adjust the automatic valves using the Sherco diagnostic tool. [3.4 Actuator test \(Page: 66\)](#)

Transmission control

Clutch

- Check the stopper, needle bearing and washer for wear.
- Check the push rod for wear :
Minimum length: 185,48mm.
- Check the length of the spring :
Minimum length: 45mm.
Replace the 6 springs if it necessary.
- Check lined discs :
Minimum thickness: 2.68mm.
- Check the smooth discs, check for deformation :
Maximum deformation: 0.2mm.

» Gearbox.

- Check all of the gears :
 - Check the coupling dogs **1** .
 - Check the pinion teeth **2** .
 - Check the fork grooves **3** .
-
- Check the condition of the shifter lock forks.
Thickness limit value: 4.87 mm
 - Check the selector drum; make sure that there is no deformation or abnormal wear.
Replace the selector drum if necessary.

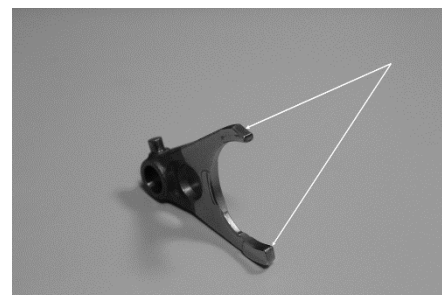
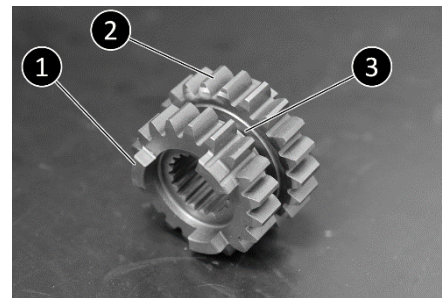

ENGINE REASSEMBLY

» Assembling the crankshaft and the gearbox

Start by cleaning the engine casings thoroughly, do not hesitate to blow into the lubrication passages and remove all impurities.

- Install a new O-ring **1** at the end of the crankshaft.

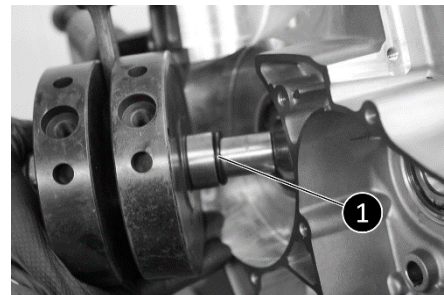

- Simultaneously install the two-gear box shaft assembly.

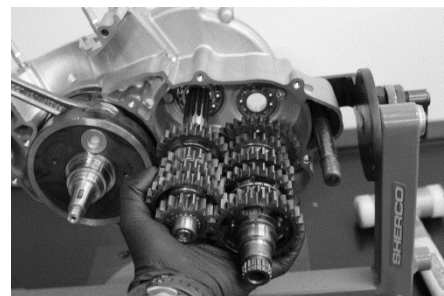

- Install circlips **2** on the secondary shaft on the clutch side.

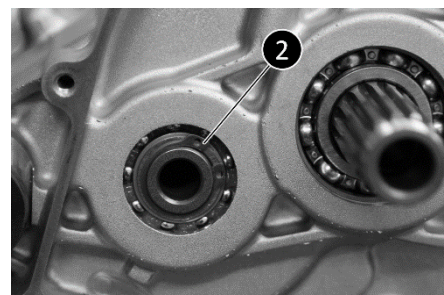

- Replace the selector drum.
- Coat the fork guide pins with grease and install the rollers **3**.

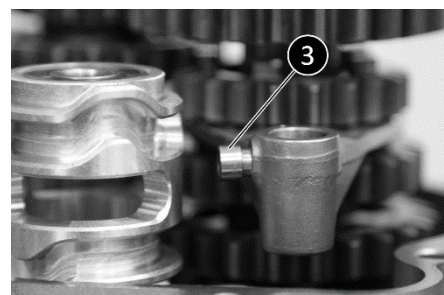

Warning: Always replace the fork roller with new ones when reassembling.

- Lubricate the fork axles **4** with oil, put them in place by carefully installing the forks in the track in the selector drum.

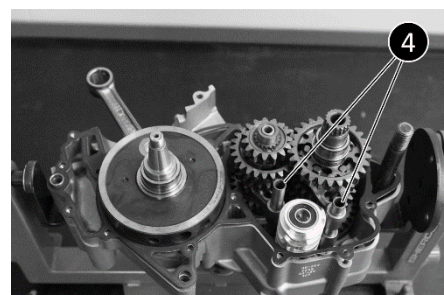

ENGINE REASSEMBLY

- Place an O-ring on the end of the lubrication tube **5** and install it in the crankcases as show.

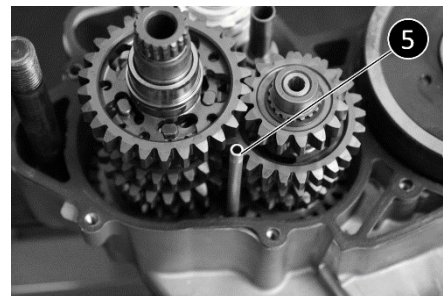

- Install the location pins on the crankcase housing.
- Install a new gasket.
- You can install the ignition side crankcase housing.
- Tighten the 12 vis **6** to 10Nm.

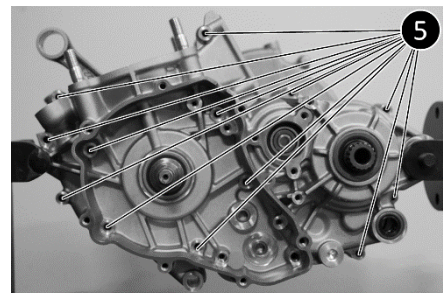

» Assembly the ignition and starter assembly.

- Place the crankshaft sensor in position and attach with its 2 screws **1** tighten to 7Nm.

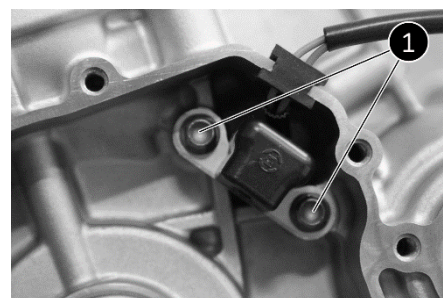

- Install the half-moon key in the slot in the crankshaft.

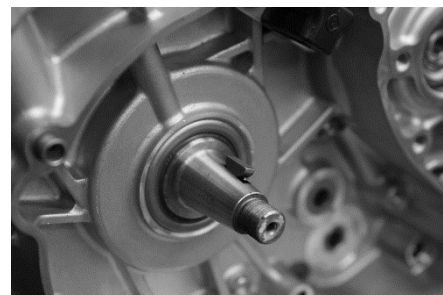

- Install the rotor on the crankshaft.
- Apply blue thread locker to the threads.
- Use tool 4753 to hold the rotor and tighten the nut to 60Nm.

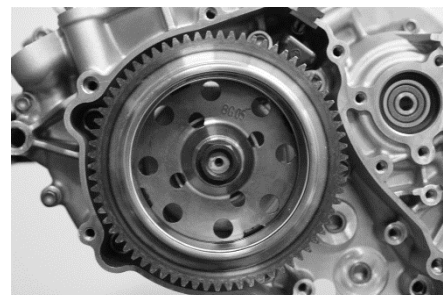

» Gear selection mechanism.

- Install the spring in the housing with curved ends up. The other end of the spring should rest against the housing
- Install the spacer, the locking finger, and the washer, apply blue thread locker to the screw tighten to 10Nm.
- Install the indexing star and pin on the drum.
- Pull the lever back to engage the indexing star.
- Apply blue thread locker to the screw and assemble the selection star to the drum. Tighten the screw to 10Nm.
- Lubricate the selector axle assembly and install it along with the needle bearing without forgetting the shim washer.
- Make sure the return spring fingers are properly located against the housing.
- Install the gear selector and make sure that all of the gears can be accessed. When does this operation the gearbox output shaft must be rotated.
- Remove the gear selector.

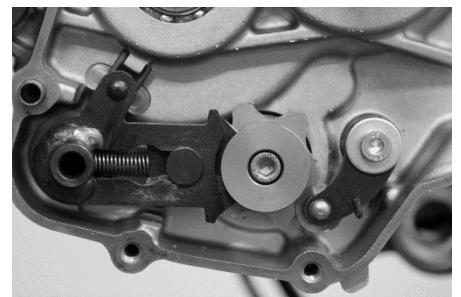
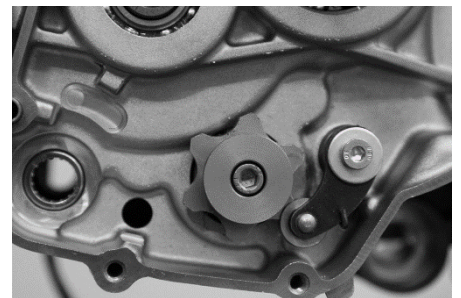
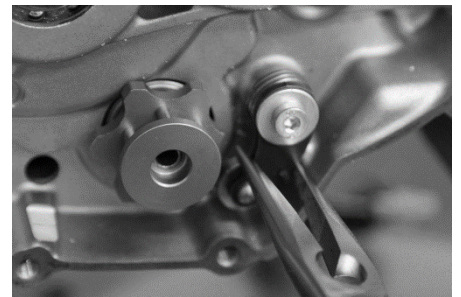
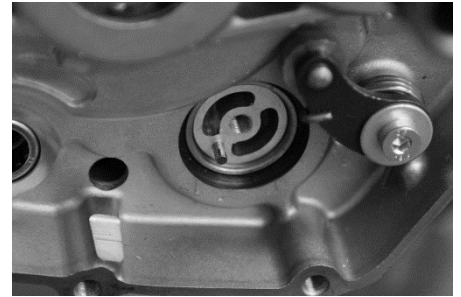
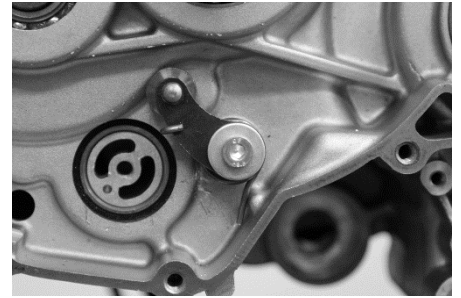

» Primary transmission and clutch.

- Lubricate the crankshaft seal and insert it into its housing.
- Install the spacer **1** that you have pre-oiled on the crankshaft.
- Install the half-moon key on the crankshaft.



- Install the conical washer **2** and the nut **3**.

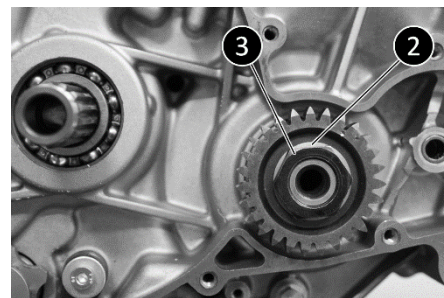

- Install the support washer **4** on the primary shaft.

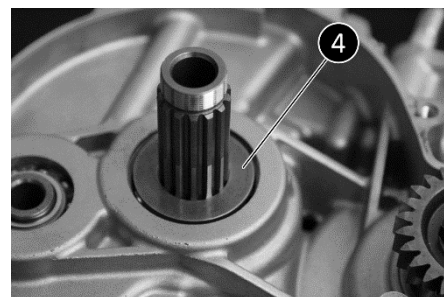

- Install the clutch housing; install the spacer **5** and the needle bearing **6** after lubricating them.



- Install the clutch support ring **7** on the primary axel.
- Install the clutch nut, the conical washer and then apply red thread lock on the threads.

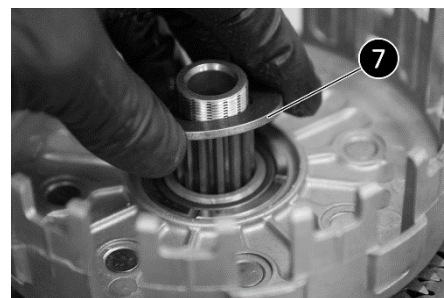

ENGINE REASSEMBLY

- Using the tool 5749 to hold the clutch housing tighten the nut to 100Nm.

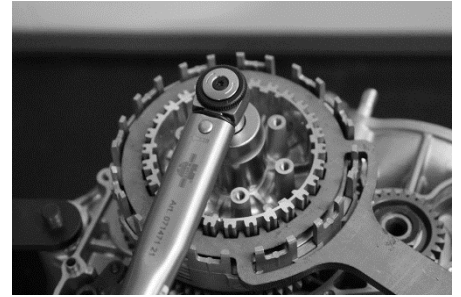

- Oil all of the clutch discs.
- Install them in the clutch basket alternating a smooth disc and a disc with fiber. A disc with the fiber should be the first disc installed

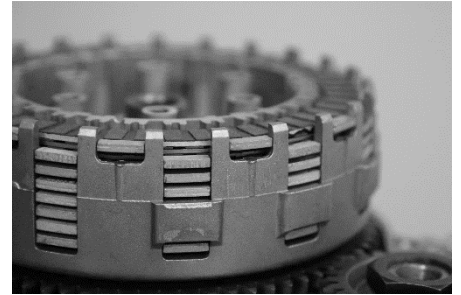

Warning: You must end up with a fiber disc which is housed differently from the others discs in the guide grooves.

- Install clutch-actuating mechanism and install the needle bearing **8** and the washer **9**.

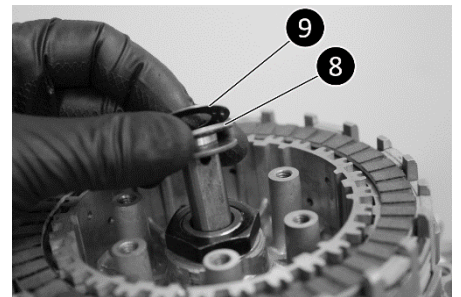

- Install the pressure plate, the clutch springs and the screws in their cups. Tighten the CHC to 10Nm.
- Using the tool 5206 tighten the primary pinion nut to 150 Nm.
- Check to make sure that the assembly rotates freely.

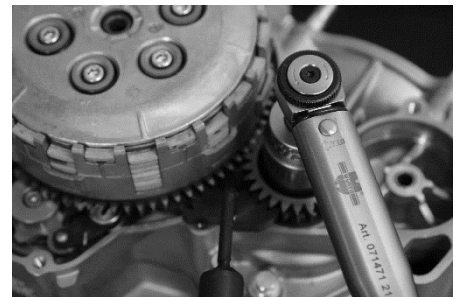

- Install the locking washer on the water pump balance wheel shaft.
- Install the axle tacking care to align the timing marks on both gears as shown in the picture.



» Clutch housing.

- Check to make sure that the two locating sleeves are securely in place in the housing.

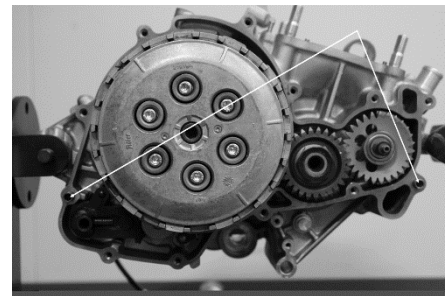

- Install the clutch housing along with a new seal.
- Install 5 clutch cover screws **1** tighten to 10 Nm.
- Tighten the water pump rotor **2** to 10Nm.

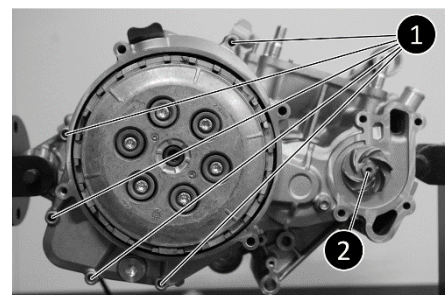

- Install the water pump housing along with a new O-ring. Tighten the screws to 10 Nm.

Warning: screws **3** have a sealing washer.

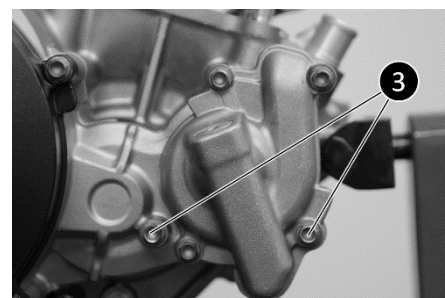

- Install the clutch housing along with a new O-ring and tighten the screw to 10 Nm.

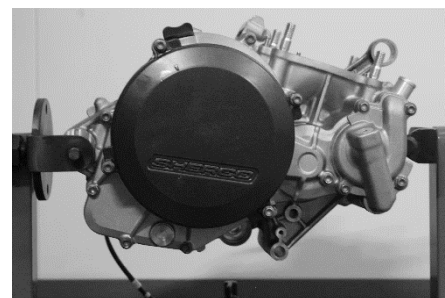

» Installing the electric starter.

- Install the torque limiter in its housing.

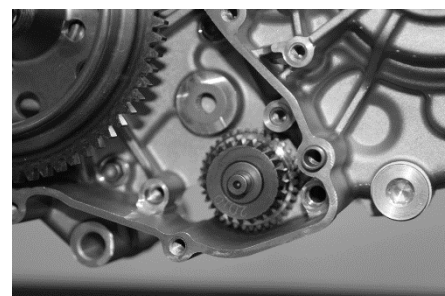

ENGINE REASSEMBLY

- Before you install the starter launcher, make sure that the support washer is installed.

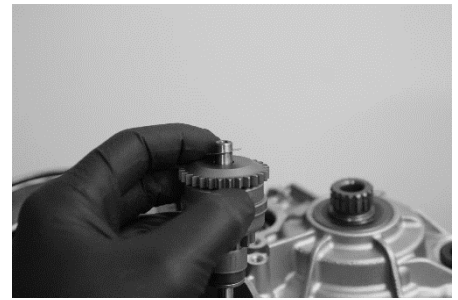

- Place the starter motor into its housing.

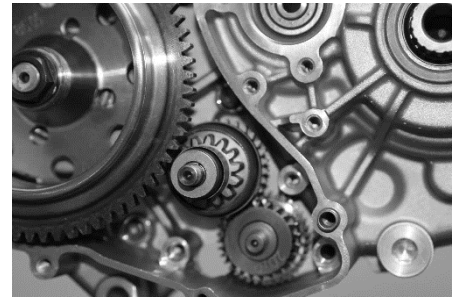

- Installed the 2 locating pins for the limiter support.

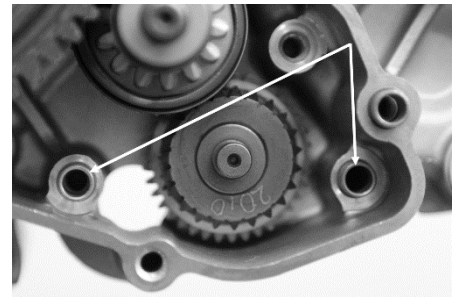

- Install the limiter support; grease the pinion with spray grease.
- Tighten screws to 10Nm.

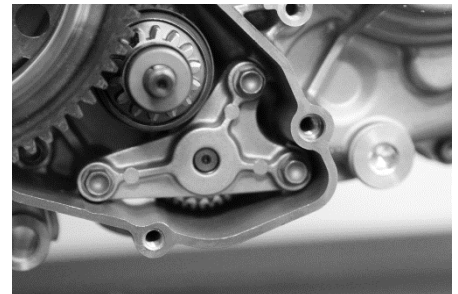

» Piston et cylinder

- Oil all the parts thoroughly before installation.
- Place tool 5774 as shown.

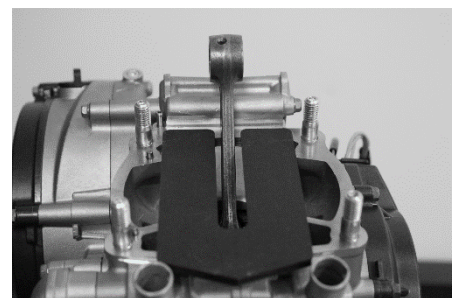

ENGINE REASSEMBLY

- Control the squish by measuring the distance between the flat of the piston at top dead center and the cylinder head plane. Depending on the value obtained from the squish chart below it may require the installation of one or more base gasket

WARNING
To correctly take the measurement make sure that a 0.5mm base gasket is installed

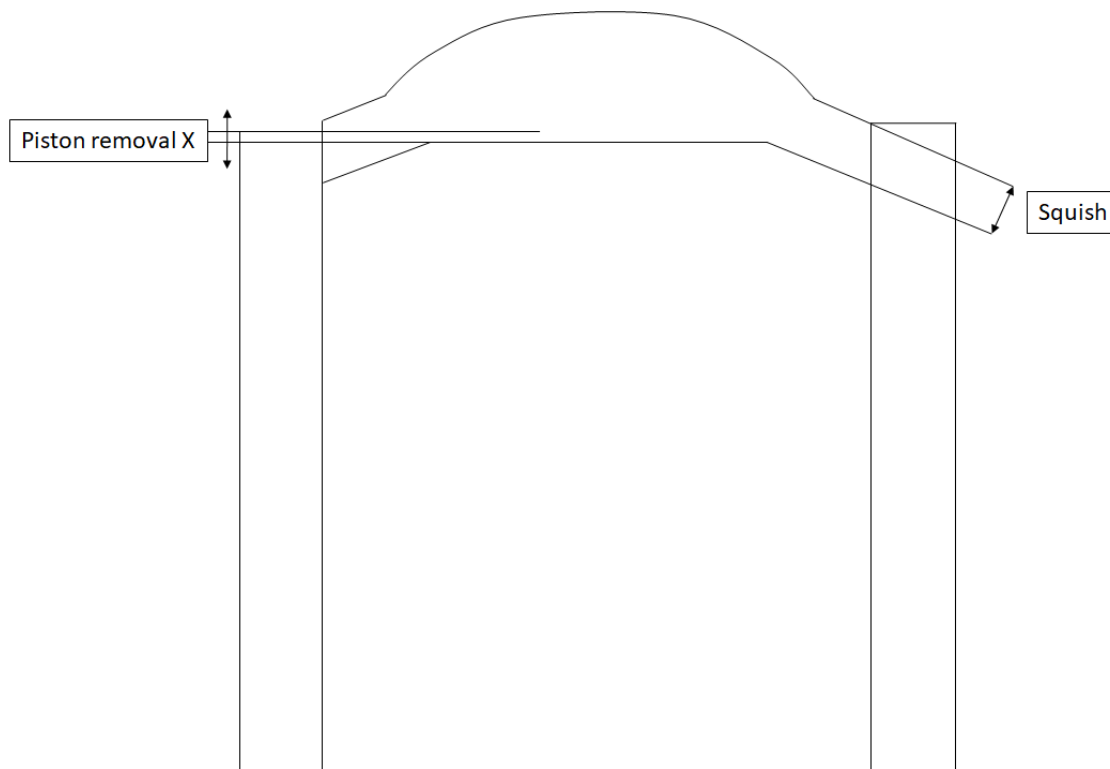

Protrusion measurement or withdrawal (-) piston (X mm)			
Made with 0.5 mm gasket	1 st squish with gasket 0.5 mm	Thickness of gasket to obtain Squich 1,7 mm	Sherco ref from gasket up to 1.7mm of Squich
$X \leq -0,25$	1,9 mm	0,3 mm	4942
$-0,25 < X \leq -0,15$	1,8 mm	0,4 mm	7238
$-0,15 < X \leq -0,05$	1,7 mm	0,5 mm	3840
$-0,05 < X \leq 0,05$	1,6 mm	0,6 mm	4942 + 4942
$0,05 < X \leq 0,15$	1,5 mm	0,7 mm	7238 + 4942
$0,15 < X \leq 0,2$	1,45 mm	0,75 mm	4943

»| Cylinder head.

- Clean the gasket surface of the cylinder and the cylinder head.
- Install two centering pins on the cylinder.
- Install the cylinder head O-ring.

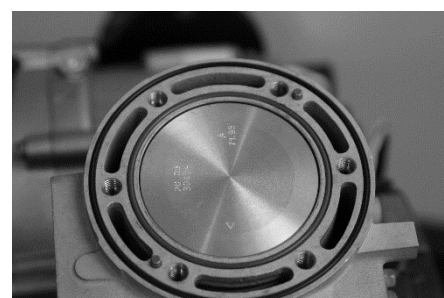

ENGINE REASSEMBLY

- Install the cylinder head.
 - Install the shoulder bolt along with new cooper washers.
 - Tighten the bolts in tree passes and crosswise to 25Nm.
-
- Coat the temperature sensor with waterproofing Loctite ® 577.
 - Install the temperature sensor along with a new seal and tighten to 20Nm.

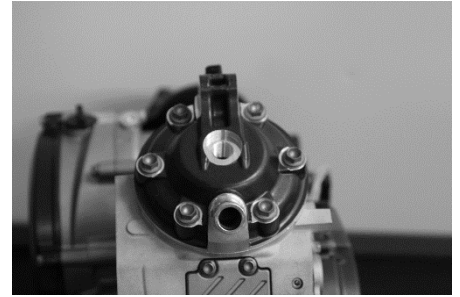

» Reed valve and intake pipe

Over time the carbon reeds can gradually lose their elasticity which causes a loss of power.

Replace damaged or worn reed valve assembly.

- To ensure a good seal apply sealer to the housing junction.
-
- Install a new reed box seal.
 - Install the reed valve in the inlet pipe.
-
- Install the 4 screws and tighten to 10 Nm.
 - Inspection the inlet rubber sleeve and make sure it is not cracked.

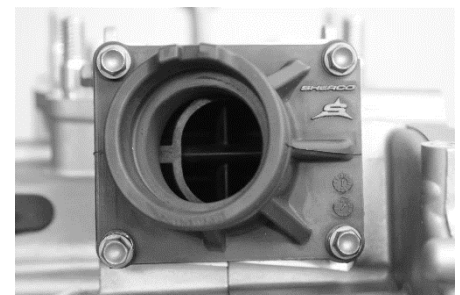
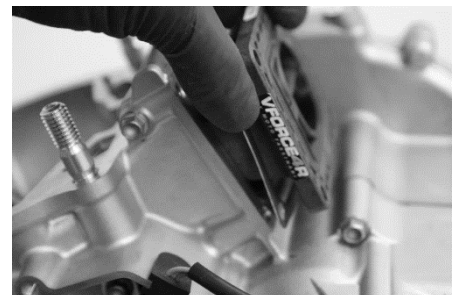
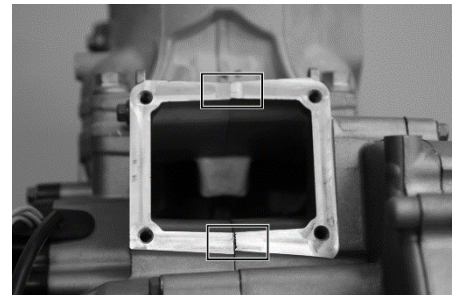

ENGINE REASSEMBLY

- Install the clamp on the inlet pipe.

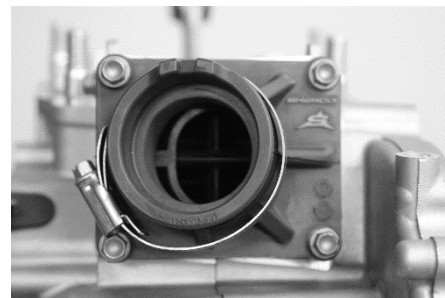

» Installation of the ignition cover.

- Install the 2 guides **1**.
- Install a new gasket.

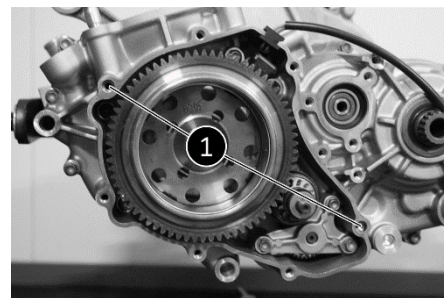

- Install the cover.
- Tighten the 8 cover screws and tighten to 10Nm.
- Install the inspection cover and tighten to 8Nm.

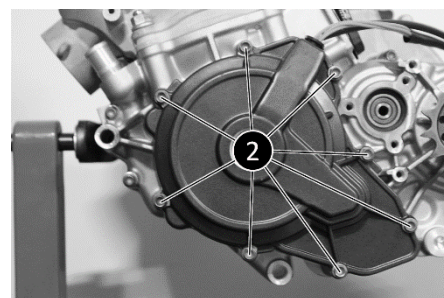

» Gearbox output pinion and clutch push rod.

- Install the gearbox output pinion of the secondary shaft and install the circlip **1**.
- Oil and install the clutch push rod **2** in the primary shaft.
- Replace the drain plugs and fill the crankcase with gear box oil.

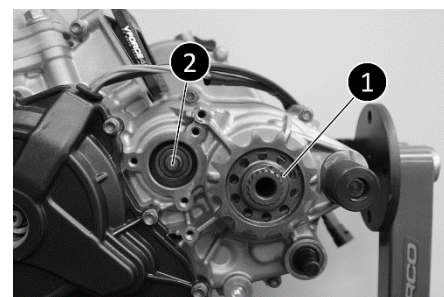

» Water pump / balance shaft bearing.

- Start by removing the clutch housing (See: [Disassembly of the right side](#)).
- Remove the water pump / balancer shaft.

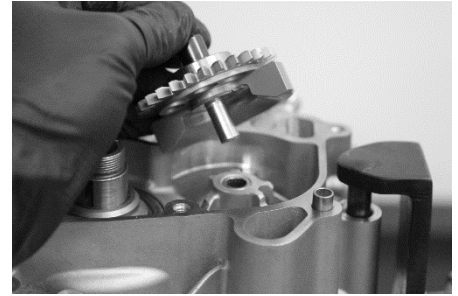

- Use tool 8987.



- The tool consists of the 6 different parts.

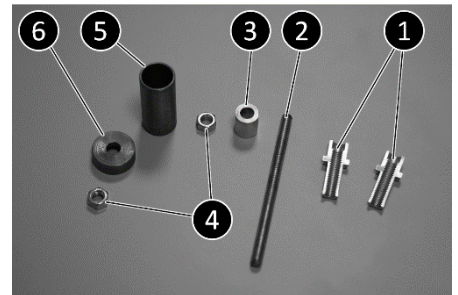

- Insert the claws **1** one by one into the bearings, both bearings must be removed at the same time.

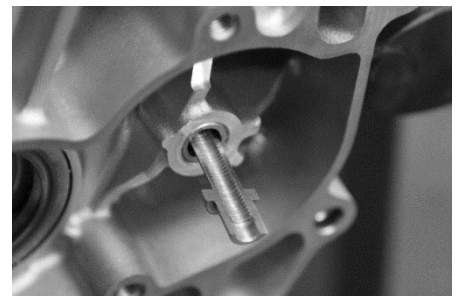

- Once the claws are in the bearings install ring **3** on it.

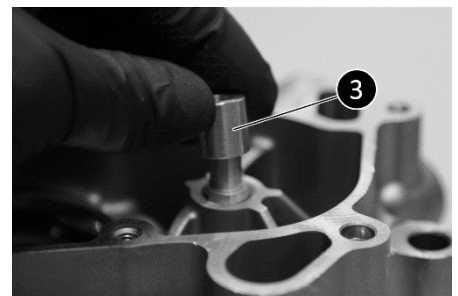

REPLACING ENGINE COMPONENT

- Screw the threaded rod **2** into the claws.
- Install nut **4** while keeping the claws **1** and the spacer **3**.
- Heat the crankcases around the periphery of the where the bearings are installed.
Warning: Do not hesitate to heat well at the risk of damaging your tool.
- Install the spacer **5** and its cover **6**,
Tighten the second nut **4** to remove the bearings.
- Install the 2 new bearings on the tool 10027, heat the periphery of the housing and use a press to simultaneously press both new bearings into the bottom of the housing.
- **Warning:** Press the bearings in smoothly so as to not risk getting metal between bearings.

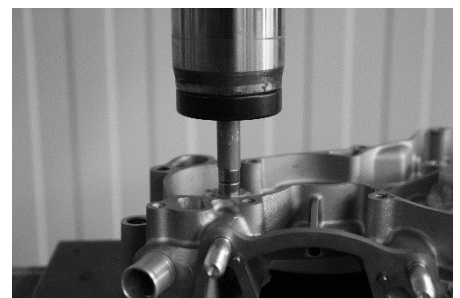
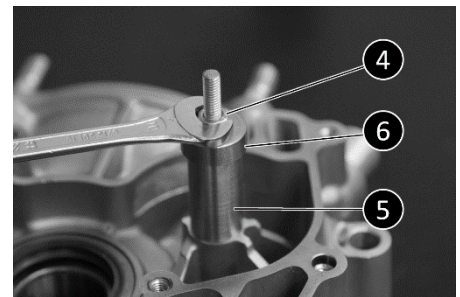
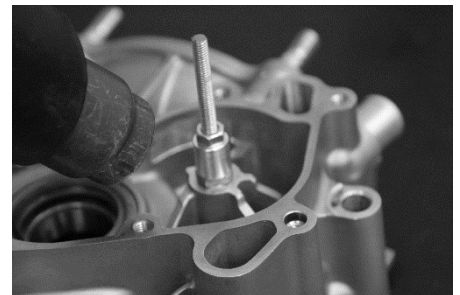
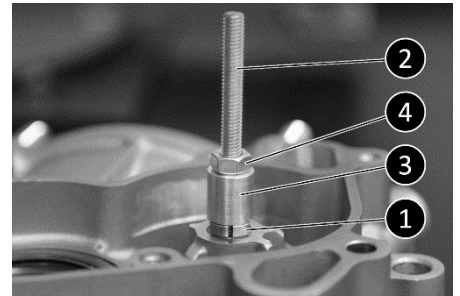
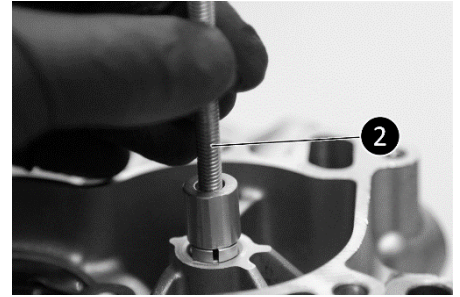

ELECTRICAL PART

» Electrical components

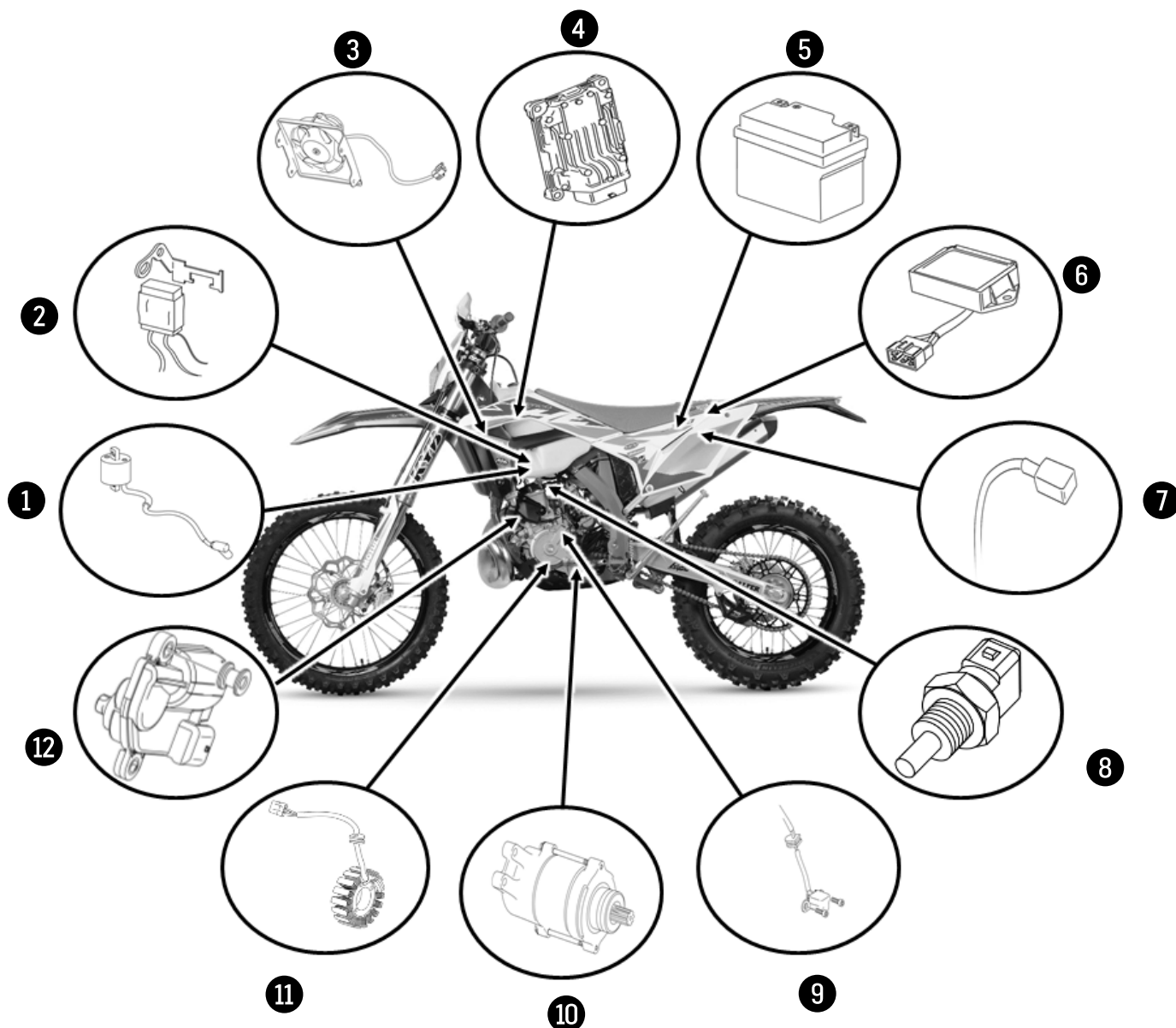

Position	Designation	Position	Designation
1	Coil	7	Relay
2	Additional CDI	8	Temperature sensor
3	Fan	9	Hall sensor
4	CDI	10	Starter
5	Battery	11	Alternator
6	Regulators	12	Valve motor



4-Battery check

- Connect a multimeter to the + and - battery terminals and check its voltage

Value read:

12.8V → Battery charged

12.7V or less → Charge battery

Less than 12V → Replace battery

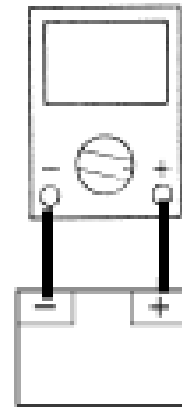

5-starter check

- Remove the starter and position it in a vice
- Connect a battery directly to the starter (positive on the starter terminal and the negative on the starter body) as shown in the diagram.
- In the event of abnormal operation, open the starter and clean the contacts between the starter brushes and the armature.

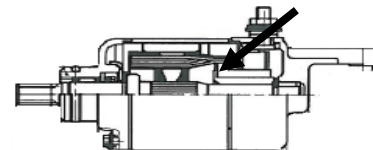
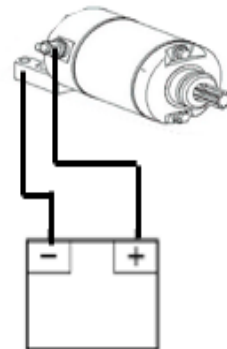

6-Checking the alternator

- Checking the resistance of the alternator windings.

Connect a multimeter between each phase of the alternator (Yellow wire) and measure the resistance.

Winding resistance: $0.44\Omega \pm 15\%$

- Checking the output voltage of the alternator.

Connect the multimeter between each phase of the alternator (Yellow wire) and ground (Multimeter in alternative position) Measure the output voltage.

Idling: 22V +/- 2V

At 6000 RPM: 77V +/- 3V

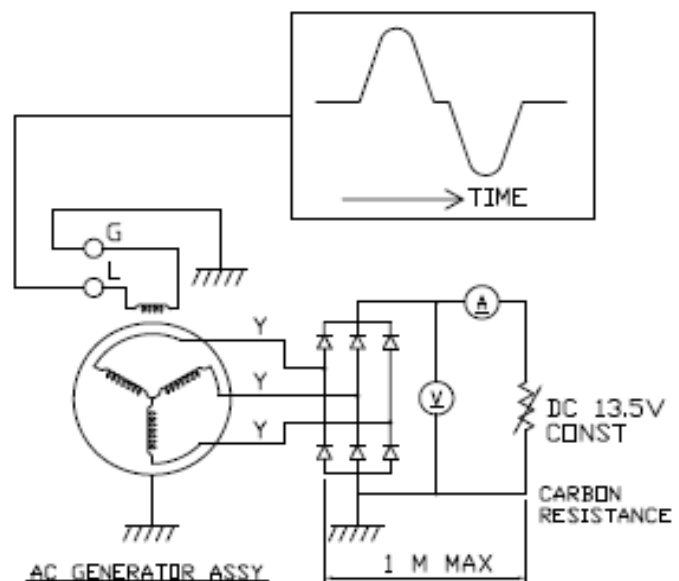

7-Checking the (crankshaft) hall sensor

- Sensor resistance check.

Connect the multimeter between the red and green wire of the sensor and measure the resistance.

Sensor resistance: 100 Ω +/- 20%

- Checking the output voltage of the sensor.

Connect a multimeter between the blue wire and ground and measure the voltage.

At 300 RPM: 1.7V minimum

At 10000 RPM: 120V maximum

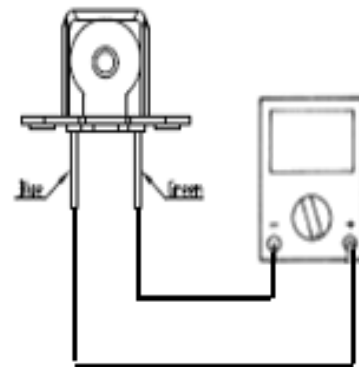

8-Temperature sensor check

- Drain the coolant.
- Remove the temperature sensor.
- Immerse the sensor [1] in a container filled with cooling liquid [2] and leave the terminals out of the liquid.
- Immerse a thermometer [3] in the liquid to observe the temperature.
- Heat the liquid slowly and check the resistance of the sensor using a multimeter connected as shown in the diagram as a function of the liquid temperature.

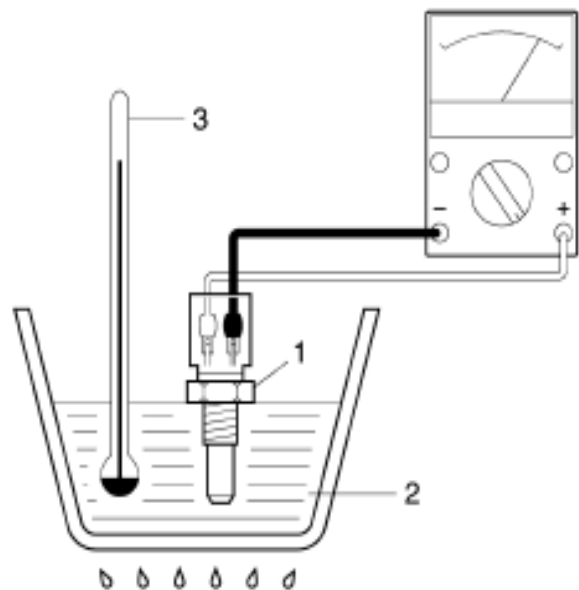

TEMPS (°C)	RESISTANCE (Ω)
25	3000
30	2415
40	1620
50	1081
60	748
70	528
80	379
90	278
100	206

›| 9-Checking the ignition coil

- Remove the ignition coil.
- Using a multimeter, measure the primary coil resistance in the following manner.
- Primary coil: measure the resistance between the ground and the coils output to the CDI.
- Secondary coil: measure the resistance between ground and the spark plug.
- **Primary resistance: 0.30 K Ω +/- 15% à 20°C**
- **Secondary resistance: 6.3 K Ω +/- 20% à 20°C.**

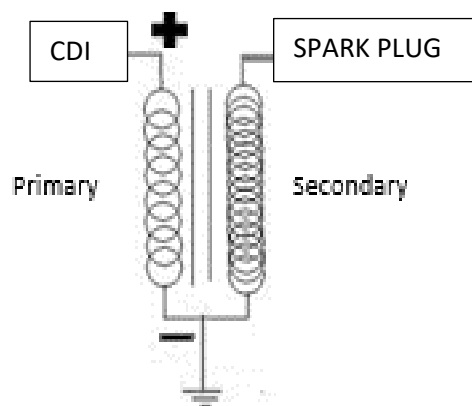

›| 10-Checking the valve moto.

- In order to check the valve motor, refer to the diagnostic check: [3.4 Actuator test \(Page : 66\)](#)



SYNERJECT INJECTION SYSTEM PRESENTATION

1.1- Components Identification

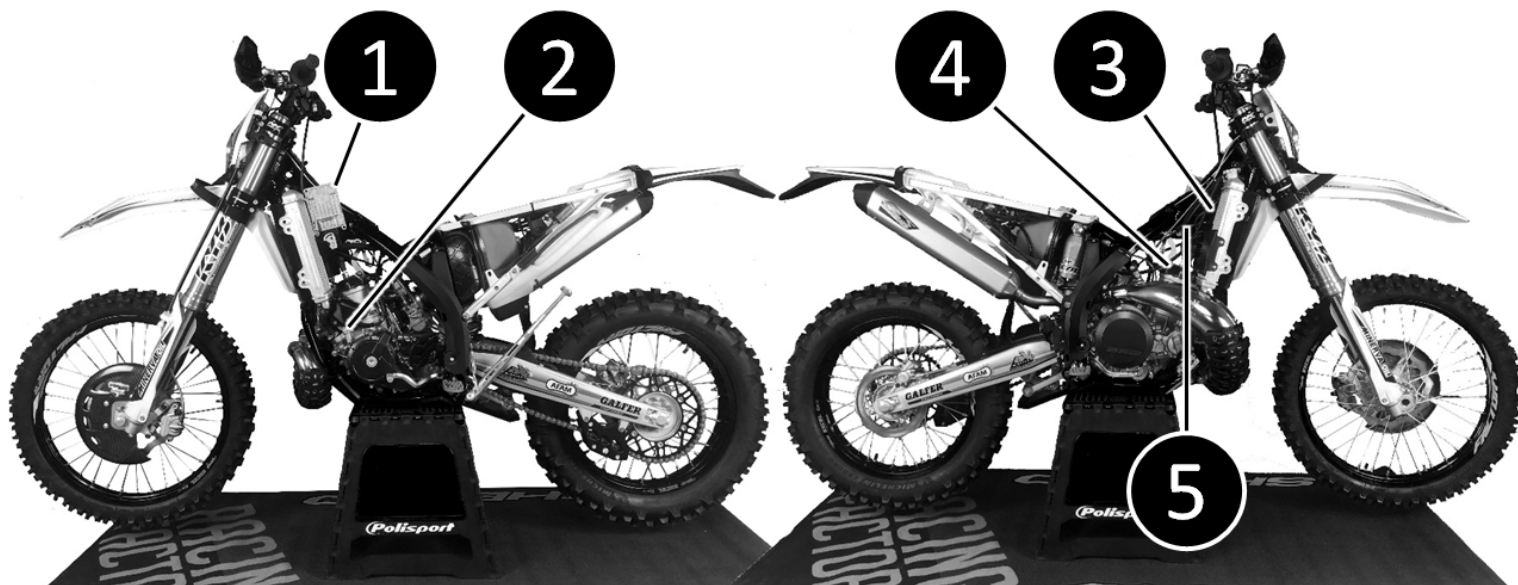

1 Synerject M3C : 3459

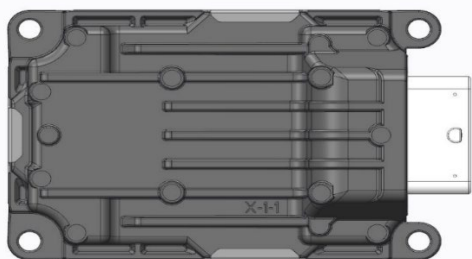

2 Valve motor : 6933

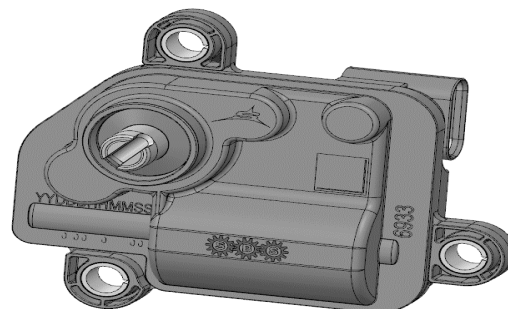

3 Ignition coil: SE 250 ref 4003 / SE 300 ref3461

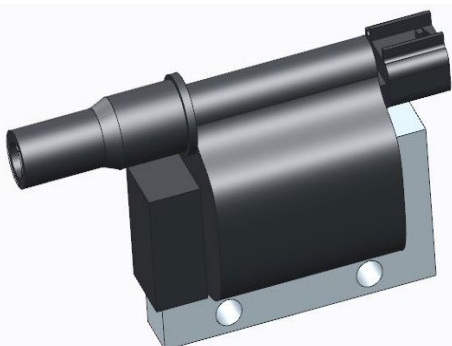

4 Temperature sensor: Ref 0380

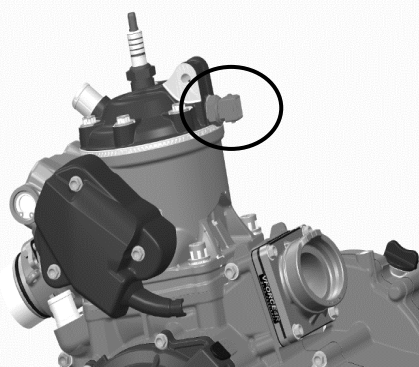

5 Additional CDI : SE 250 ref 8456 / SE 300 ref 10108

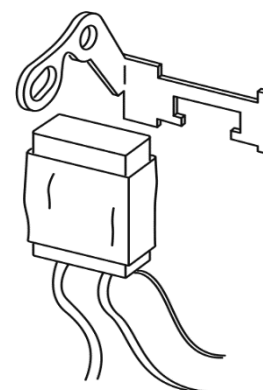

1.2- Description Exxodiag diagnostic Tools Ref: kit 8561

The diagnostic tool allows you to perform diagnostic operations, make updates to the injection mapping and to determine certain information (serial number of the motorcycle, number of hours of operation, etc.).

1.3- Diagnostic tool kit contents.

The diagnostic kit (Ref : 8561) consists of a USB to MUX output cable, a MUX device, a MUX to motorcycle diagnostic connector cable, a shunt and a user manual.

http://download.annecyelectronique.com/Exxodiag/Sherco/ShercoDiag_Setup.exe

1.4- Installation of the diagnostic tool.

In case of problem during the installation please contact EXWOTEST at +33 (0)4 50 02 34 34 or by mail to courrierxxotest.com.

A- Installing the software and drivers

- Open the installation link on your computer

- Run “ sherco_setup”

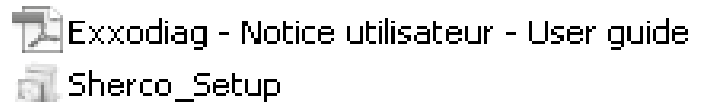

- Select the desired language.

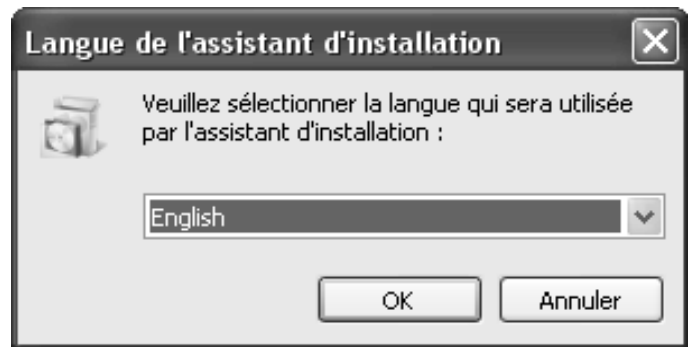

- Click on “Next”.



- Select the folder where you want to install the software.

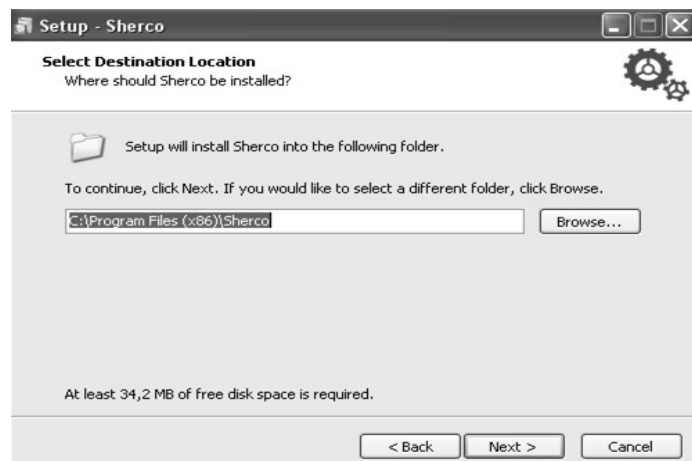

- Click on “Next”.

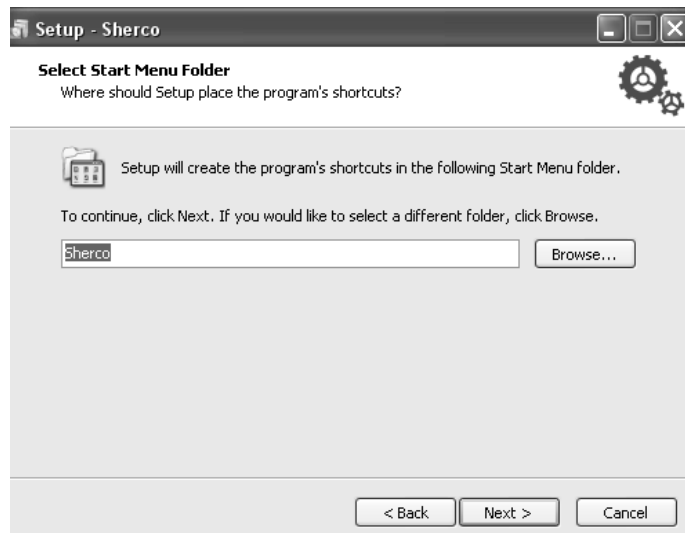

- Click on « Install ».

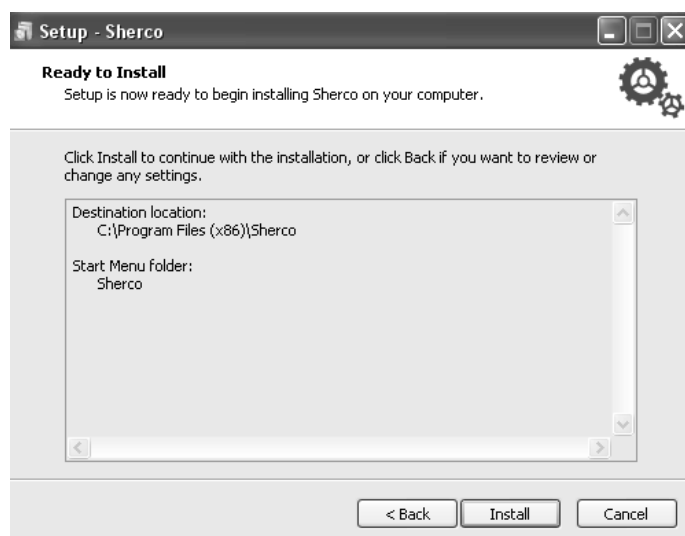

- Installation in progress.

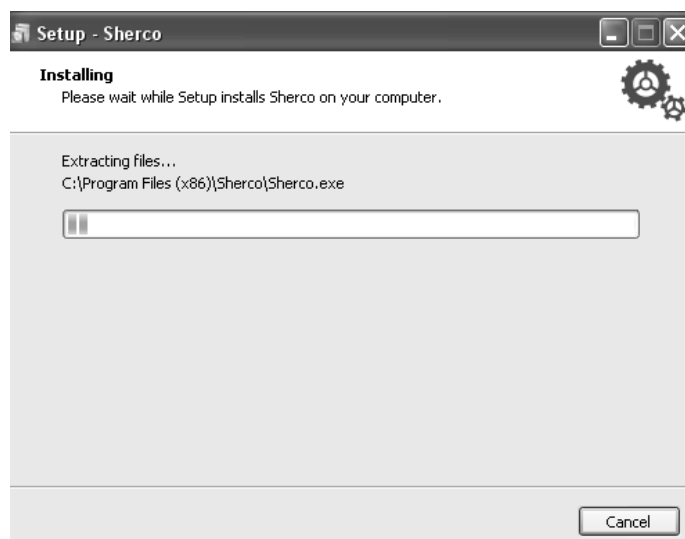

- Check the box “Start the driver installation” and click on “Finish”.



- The next window opens. Read the terms of the License Agreement Check « I accept the terms of the License Agreement » and « Install »



- Installation in progress.

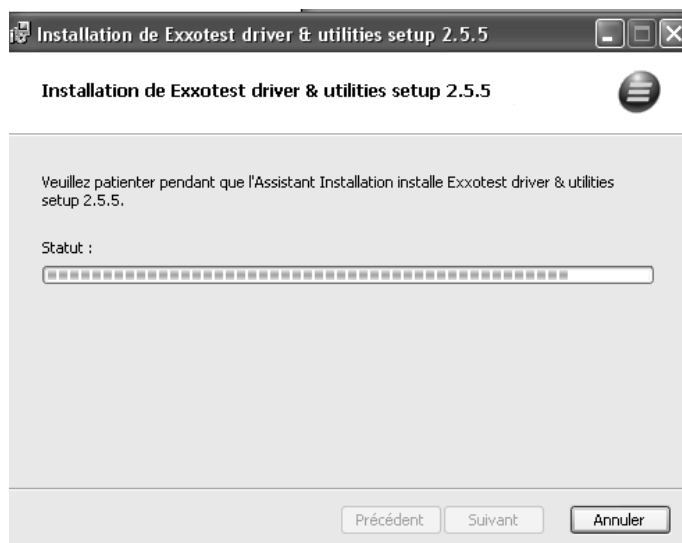

- The following window will open. Click on « Finish »

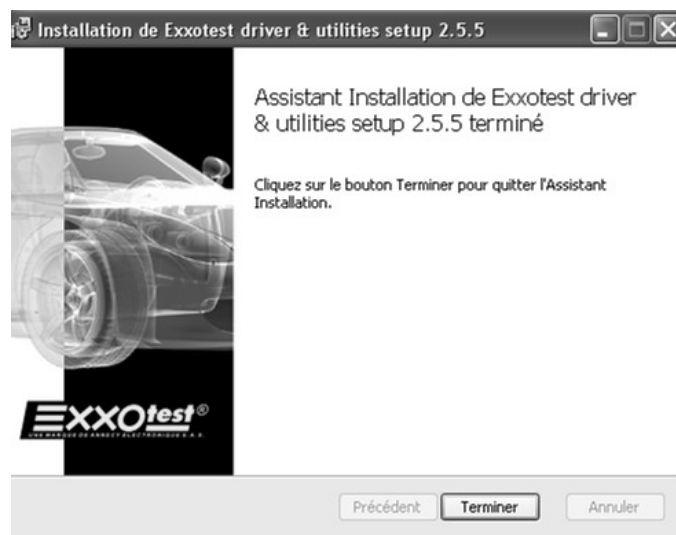

Installation is now complete.

B-Connection between computer, « Muxdiag II » and motorbike

Connect the cable to the diagnostic connector of the motorcycle.

Make sure the “Muxdiag II “unit is properly powered by checking the LED:

- **Fixed blue:** Computer connection properly established.
- **Flashing blue:** Computer connection in progress.
- **Blue off:** No connection with the computer, or device in standby, it can also indicate a problem with the USB connector.
- **Fixed green:** Firmware issue.
- **Flashing green (slow):** Correct execution of the firmware.
- **Flashing green (quick):** Communication with the computer in progress.
- **Green off:** No firmware.
- **Fixed red:** Correct power supply to the card.
- **All LEDs off:** The outlet is not powered on, or is off or USB is on standby mode.

PRESENTATION OF THE SOFTWARE

2.1- Connection with keyless system

Sherco has equipped its motorbikes with a “keyless” system that allows keyless operation and automatically turns off the ignition after 30 seconds of inactivity. This last point prevents the diagnosis from being made; which is why it is essential to follow the following step before any operations

1. Remove the plug **1** from the connector **2** (located on the rear sub frame – on the right part of the bike).

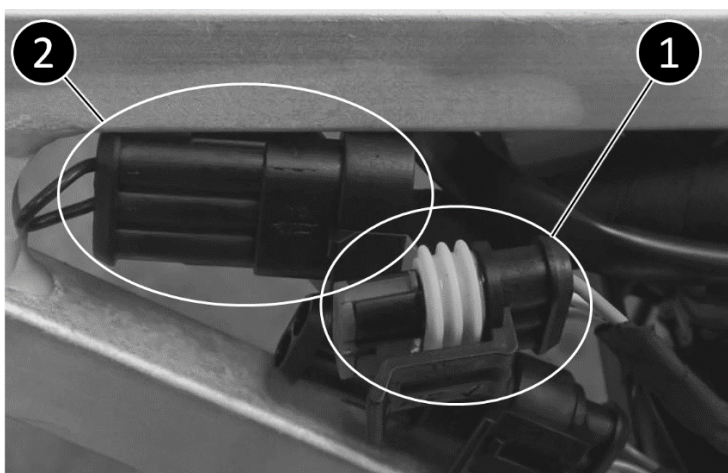
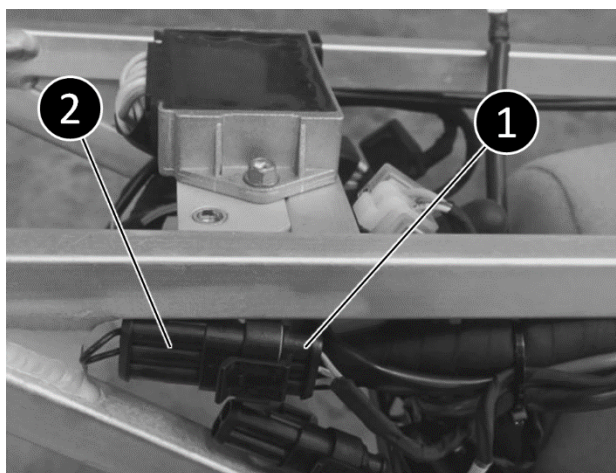

2. Take the shunt **3** (Ref: 6267) and connect the plug **1** into it.

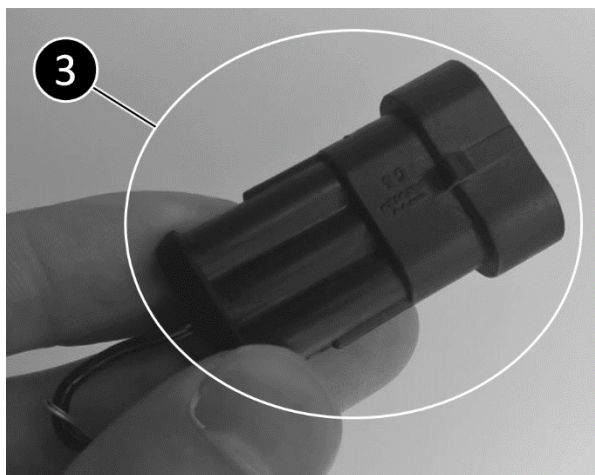

3. You can now do the diagnostic by following the next explanations.



DIAGNOSTIC TOOL SYNERJECT

Information: To set up the connection with the motorcycle, the motorcycle must be switch on with the shunt.

To navigate through the different menus, only the USB cable with the “Muxdiag II” box must be connected to the computer.

Start the software using the icon on your desktop:



The following menu will come up:

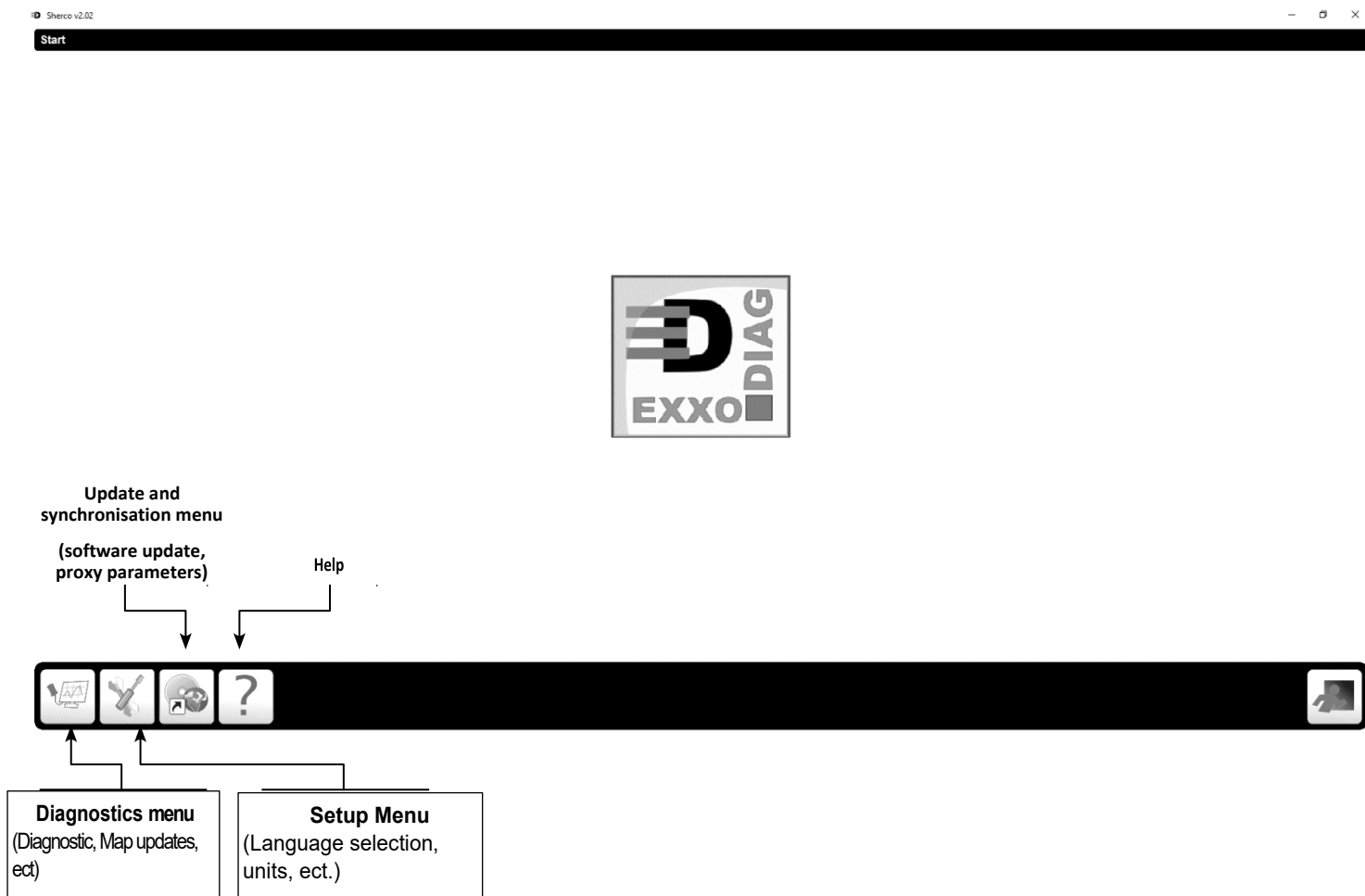

2.2 Software settings

- Configuration menu: 



In this menu, you can modify:

- The diagnostic plug. You can refresh the list by hitting the button. 

The number must match the number of your « Muxidiag II » device.

- The language available in the software: French, English, Spanish, Portuguese, German, Italian.

Make a software update; see: [2.3- Update menu and synchronization \(Page 60\)](#)

- Set the units.
- Click  to return to the home screen.
- Click  to save the changes.

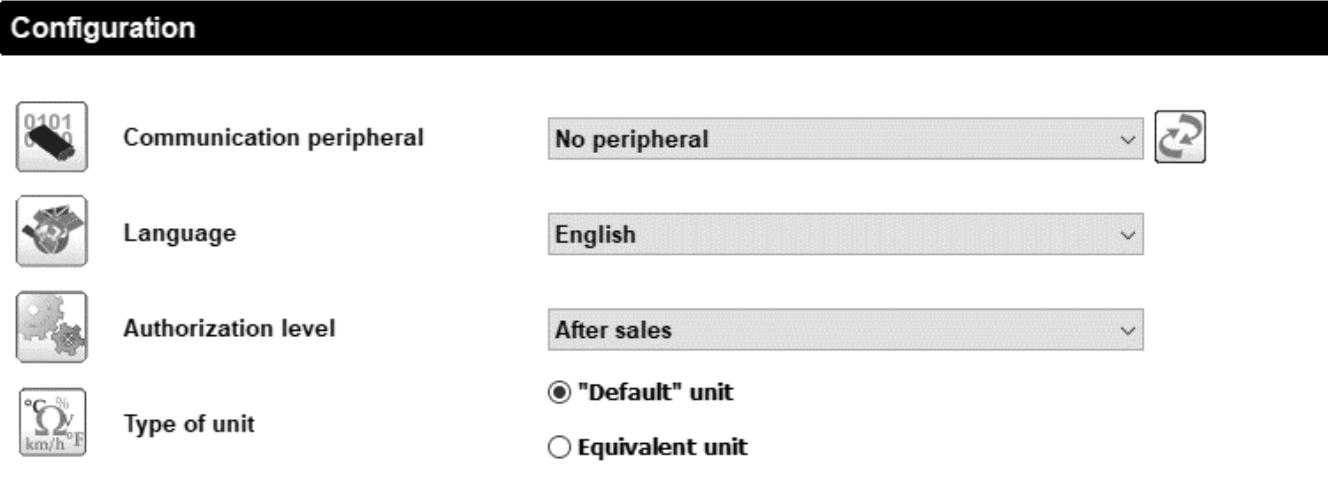

2.3- Update menu and synchronization



A- in this menu, you can update the diagnostic software tool.

- To find out if an update is available, check that you have an internet connection, then click on the following icon



- If an update is available this window will appear :

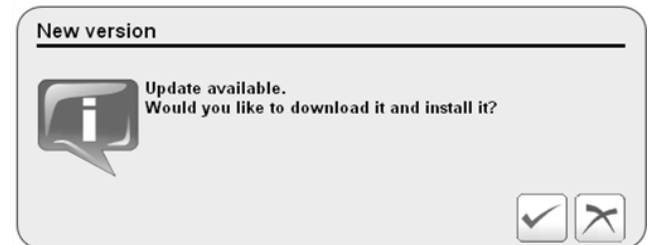

- If no update is available, the following window will appear :



- Click on  to start downloading the update.

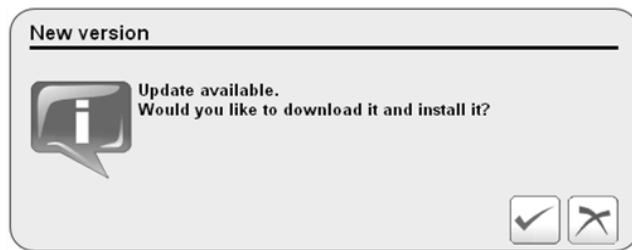

- The following message will come up.
- Click on  to start the installation



- Repeat the installation steps. It is not necessary to repeat the driver installation.

B- Configuration of internet access parameters

It may be necessary to set up a proxy server to access the internet.

- Click on 

- Fill in the following settings necessary

Configuration of proxy settings

None

Use the following settings

Customized settings

Address / Port	<input type="text"/>	<input type="text"/>
User	<input type="text"/>	
Password	<input type="text"/>	

- Click on  to save your changes.

3 - Use of the software

Diagnostic menu and injection mapping update.



General

- Click on « Sherco' ».

Choose vehicle

 After sales
 USB MUX DIAG V2
N°5438

Sherco

- Click on « M3C ».

Choose ECU

 After sales
 USB MUX DIAG V2
N°5438
 Sherco

M3C

- You reach the following menu :

Choose vehicle

 After sales
 USB MUX DIAG V2
N°5438
 Sherco
 M3C

	Identification
	Parameter reading
	Trouble codes reading
	Trouble codes clearing
	ECU updating
	Actuator tests

3.1 Identification

Identification check (Serial number, Vehicle operating hours, calibration number....)

Reading of current setting...

 Factory
 USB MUX DIAG V2
N°5438
 Sherco
 M3C

VIN code	VNBS430E32B001821
Overall engine operating hour counter	0.0 h
ECU Board Serial Number	2011929783
Software Version	QR010010
Hardware Version	S180037040Z9
Calibration	25EUS01.

A. Measurement of parameters:

General parameters (Speed, temperature, pressure ect....)

Choose category...

After sales USB MUX DIAG V2 N°5438 Sherco M3C	<input type="text"/>	Engine information
	<input type="text"/>	Throttle Position
	<input type="text"/>	Misc

B. Engine information

The main values of the system appear:

Reading of current setting...

After sales USB MUX DIAG V2 N°5453 Sherco M3C 	RPM	0 tr/mn
	Engine Temperature	31 °C
	Battery Voltage	11.9 V
	Air temperature	28 °C
	Ambient pressure	1012 mb
	Stepper position	0
	Throttle position	0 %

3.2 Reading trouble codes

If you click on « trouble code reading » the system start checking.

Choose vehicle

After sales USB MUX DIAG V2 N°5438 Sherco M3C	<input type="text"/>	Identification
	<input type="text"/>	Parameter reading
	<input type="text"/>	Trouble codes reading
	<input type="text"/>	Trouble codes clearing
	<input type="text"/>	ECU updating
	<input type="text"/>	Actuator tests
	<input type="text"/>	

- If no trouble codes appears exit the menu by clicking on this icon :



- If trouble codes appears :

Breakdown list...

After sales

0101 USB MUX DIAG V2
N°5438

Sherco

M3C



Fugitive failure

Permanent failure







Throttle Position Sensor (P0122)



Electric fuel pump (P0231)



Air pressure sensor (P0107)



Intake air temperature sensor (P0113)



Stepper motor (P1508)



Cooling fan (P0485)

- You can get the details of the default by clicking on the default display :

Details of breakdown code...

After sales

0101 USB MUX DIAG V2
N°5438

Sherco

M3C



Throttle Position Sensor (P0122)

Short circuit to ground or overload

- Number of occurrence of present failure = 59
- RPM = 0 tr/mn
- Engine Temperature = -40 °C
- Battery voltage = 4.0 V
- Air Temperature = 29 °C
- Ambient pressure = 64 mb
- Applied Ignition angle = -29 °CRK
- Injection Time = 35 ms
- Engine state = ES
- Overall engine operating counter = 0 h
- Engine operating minute counter since last engine start = 237 min
- Throttle Position in degrees = 0 °TPS
- Intake manifold air pressure = 1360 mb
- Mass air flow = 40 mg/tdc
- Adaptive value of integral term of the idle speed controller = -50.00 %

- Record the defaults and exit the by clicking on this icon
- Record the defaults and exit the menu by clicking on :



Note:

1- **Fugitive/Permanent fault:** A fugitive fault becomes permanent after variable number of engine cycles depending on the components (injector, fuel pump, etc.). For a permanent fault to disappear, it is necessary to wait 40 engine cycles without the fault appearing.

2- **Fan fault:** If there is no fan installed on the motorbike, there will always be a rise in the fan fault (P0485).

3.3 Erasing fault codes

A. If fault code appears : go to the menu “trouble code cleaning “.

Choose vehicle

After sales	Identification
USB MUX DIAG V2 N°5438	Parameter reading
Sherco	Trouble codes reading
M3C	Trouble codes clearing
	ECU updating
	Actuator tests



Clear all Diagnostic Trouble Codes ?

- Click on in order to clear all the defaults codes :



- The following window appear:

Current service in execution...

After sales	
USB MUX DIAG V2 N°5438	
Sherco	
M3C	

Service in execution...

Information

Erasing of trouble codes successful.

- Confirm by clicking on :



B. Return to the “trouble code reading” menu

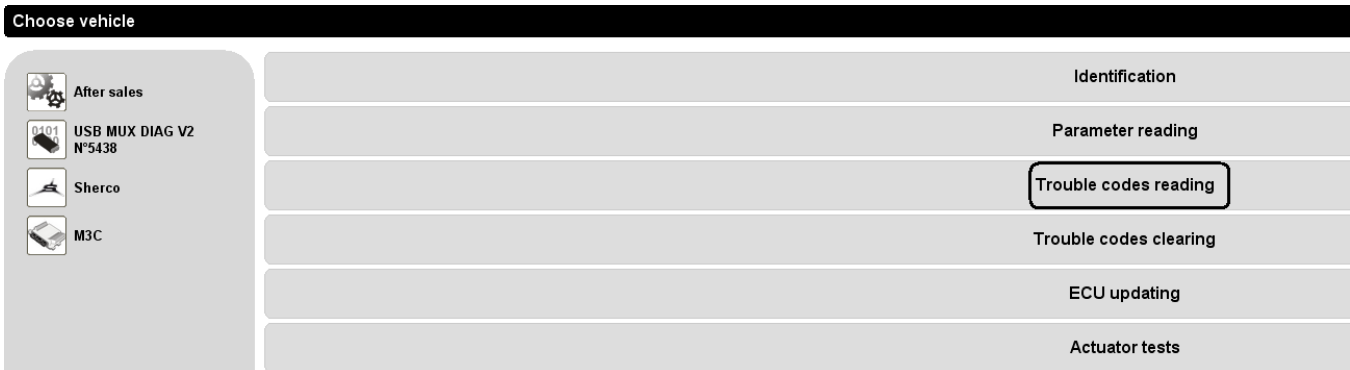

- Check and make sure that the default are the same as before. Check / Replace the defective parts.
- Check all the connections.

3.4 Actuator test

In addition to reading the trouble codes, you can also test certain system components:

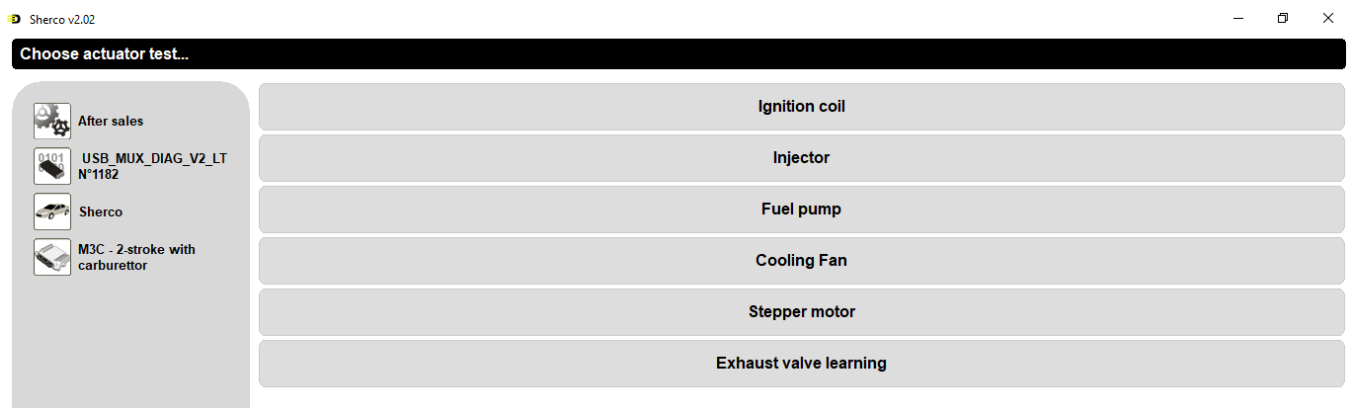

1- Ignition coil

When you launch the ignition coil test, the following message will appear:



The system is not able to detect an ignition coil failure with the engine stopped. The test result will be the same if the coil is faulty or not. Therefore, when testing the ignition coil make sure that the engine makes the correct sound for a properly functioning ignition coil.



2- Cooling fan

For the fan, the test is “standard” and the fault or correct operation will appear as a classic default.

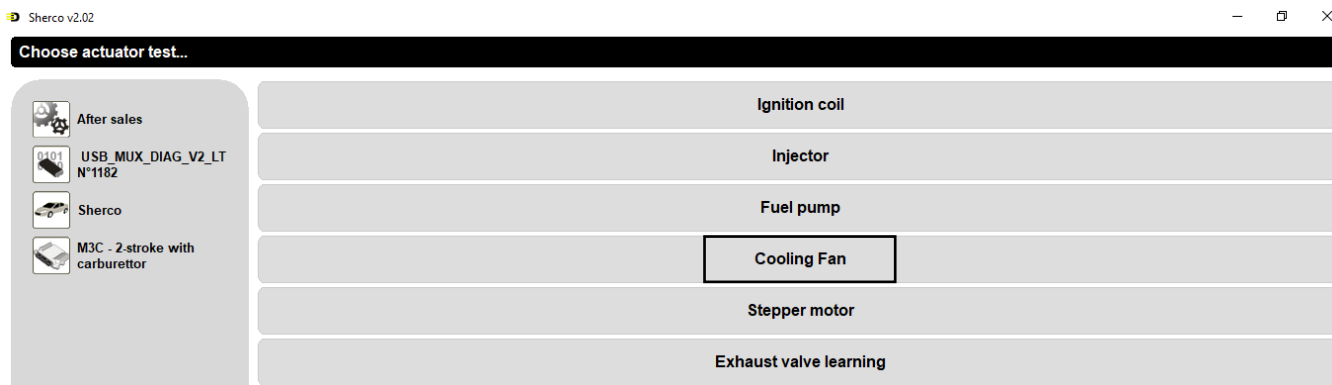

3- Valve motor learning

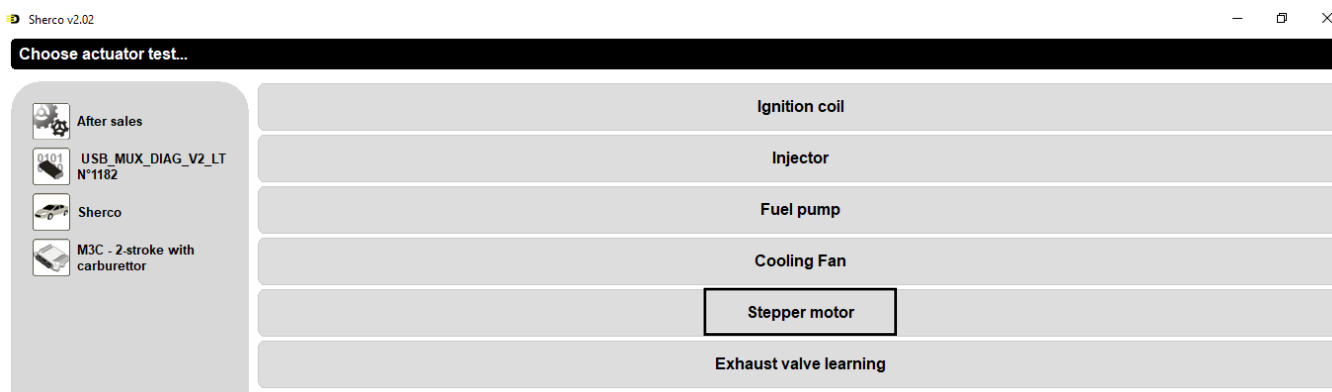

3.5 ECU update

With the diagnostic tool, it is possible to update the ignition maps (calibration). For a Racing silencer, for example, or because an update is proposed by the factory.

You must pay attention to the model, the displacement, the type of exhaust, ect...

In case of doubt, contact the technical support:

1. Download the desired update (file “.mot”)

ShercoNetwork→Information→Technical information→Injection map.

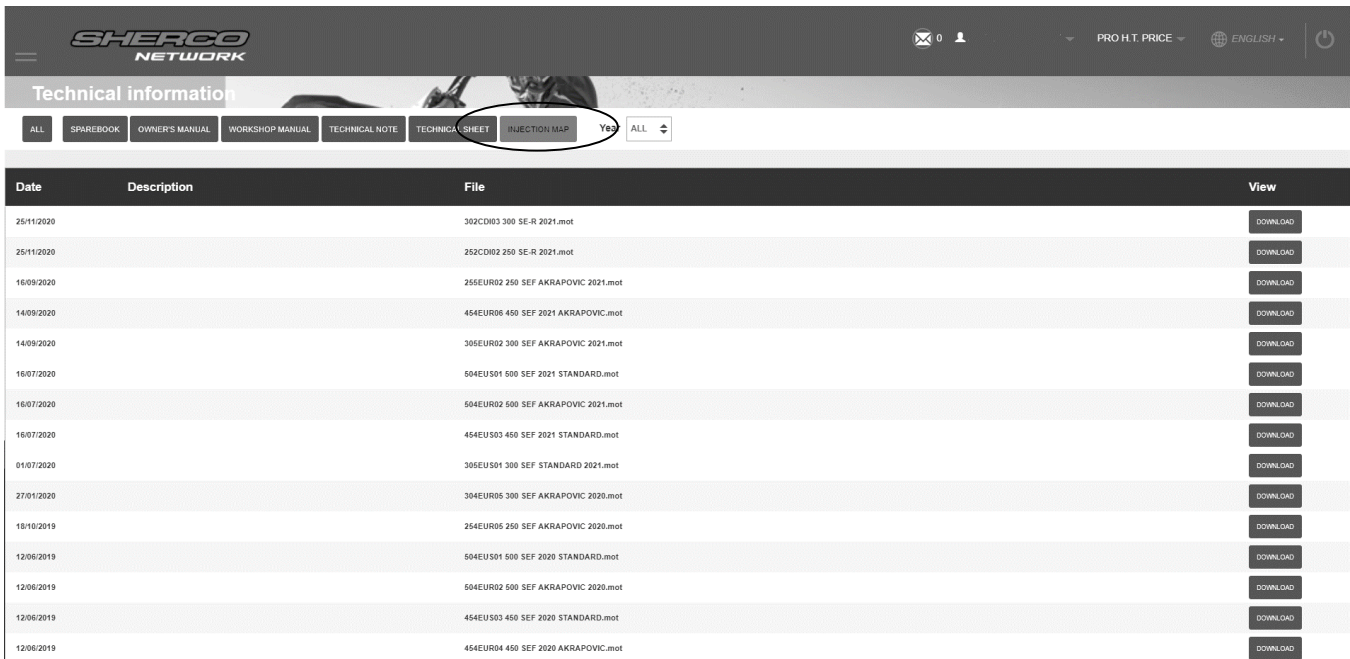

Date	Description	File	View
25/11/2020		302CD03 300 SE-R 2021.mot	DOWNLOAD
25/11/2020		252CD02 250 SE-R 2021.mot	DOWNLOAD
16/09/2020		255EUR02 250 SEF AKRAPOVIC 2021.mot	DOWNLOAD
14/09/2020		454EUR06 450 SEF 2021 AKRAPOVIC.mot	DOWNLOAD
14/09/2020		305EUR02 300 SEF AKRAPOVIC 2021.mot	DOWNLOAD
16/07/2020		504EU501 500 SEF 2021 STANDARD.mot	DOWNLOAD
16/07/2020		504EUR02 500 SEF AKRAPOVIC 2021.mot	DOWNLOAD
16/07/2020		454EU503 450 SEF 2021 STANDARD.mot	DOWNLOAD
01/07/2020		305EU501 300 SEF STANDARD 2021.mot	DOWNLOAD
27/01/2020		304EUR05 300 SEF AKRAPOVIC 2020.mot	DOWNLOAD
18/10/2019		254EUR06 250 SEF AKRAPOVIC 2020.mot	DOWNLOAD
12/06/2019		504EU501 500 SEF 2020 STANDARD.mot	DOWNLOAD
12/06/2019		504EUR02 500 SEF AKRAPOVIC 2020.mot	DOWNLOAD
12/06/2019		454EU503 450 SEF 2020 STANDARD.mot	DOWNLOAD
12/06/2019		454EUR04 450 SEF 2020 AKRAPOVIC.mot	DOWNLOAD

2. Power up the motorcycle

3. Click on “ECU updating”

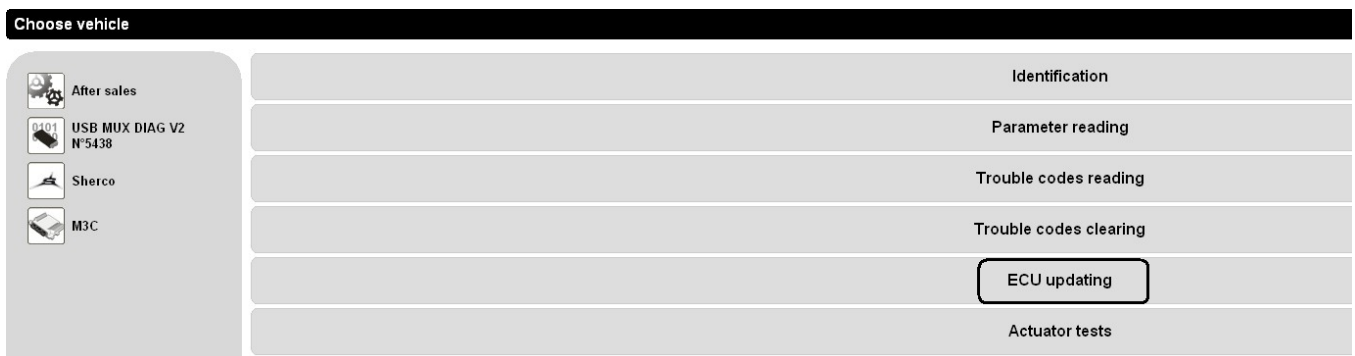

After sales

USB MUX DIAG V2
N°5438

Sherco

M3C

Identification
Parameter reading
Trouble codes reading
Trouble codes clearing
ECU updating
Actuator tests



Update ECU now ?

Confirm by clicking on this icon:



Select the previously downloaded calibration “.mot” and click open.

4. The file is being downloaded



Downloading ... (14.2%)

WARNING

Do not switch off the motorbike power supply during the download operation.
Do not switch off the software during the flash
Risk of irremediable damage to your ECU.

5. At the end of the updating the following message will appear:

INFORMATION: Download was successful

Confirm by clicking on:



6. Check the correct allocation of the calibration file by selecting « Identification »

Choose vehicle

After sales	Identification
USB MUX DIAG V2 N°5438	Parameter reading
Sherco	Trouble codes reading
M3C	Trouble codes clearing
	ECU updating
	Actuator tests

Check to make sure that the file name matches the file that was download.



Reading of current setting...

After sales USB_MUX_DIAG_V2_LT N°1115 Sherco M3C	VIN code	@@@
	Overall engine operating hour counter	151.4 h
	ECU Board Serial Number	2022042259
	Software Version	QR111010
	Hardware Version	S18003704029
	Calibration	302TSC05

Information: Serial N° and operating hour's information is not rest during a calibration update.

7. Put the "Shunt" back on the connector in the air box to switch back to "Keyless" mode.
8. The procedure of the ECU power latch will proceed during 20 seconds.
9. Wait 30 seconds for the ECU to turn off before starting the motorbike.
10. Star the motorbike, switch it off and wait another 30 seconds before the next start.
11. Start the motorbike and check that the engine parameters are normal.

3.6 Print screen function

In the event of communication with technical support and to enable quick identification of possible problems, you can attach screen print files to your message using the print screen key on your keyboard as shown below.



The "identification" tab is very important for good communication (serial number of the motorbike, engine hours, calibration, etc....)

Reading of current setting...

Factory USB_MUX_DIAG_V2 N°5438 Sherco M3C	VIN code	VNBS430E32B001821
	Overall engine operating hour counter	0.0 h
	ECU Board Serial Number	2011929783
	Software Version	QR010010
	Hardware Version	S18003704029
	Calibration	25EUS01.

TIGHTENING TORQUES

Other engine nuts	M4	5Nm	
Other engine screws	M4	5Nm	
Valve blocking screw	M4	5Nm	
Bearing lock plate screw	M5	8Nm	Blue
Electric starter screws	M5	7Nm	Grease
Engine speed sensor screw	M5	7Nm	Red
Expansion chamber cover screw	M5	7Nm	
Main valve cover screw	M5	7Nm	
Other engine nuts	M5	7Nm	
Other engine screw	M5	7Nm	
Stator screw	M5	7Nm	Red
Clutch housing screw	M6	10Nm	Grease
Clutch receiver cylinder screw	M6	10Nm	Grease
Clutch spring screw	M6	10Nm	
Coolant drain screw	M6	7Nm	Grease
Engine crankcase screw	M6	10Nm	Grease
Exhaust flange nut	M6	10Nm	
Ignition casing screw	M6	10Nm	Grease
Oil level control screw	M6	10Nm	
Other engine nuts	M6	10Nm	
Other engine screw	M6	10Nm	
Selection locking finger screw	M6	10Nm	Blue
Selection star screw	M6	10Nm	Blue
Water pump cover screw	M6	10Nm	Grease
Water pump turbine nut	M6	10Nm	Blue
Cylinder head screw	M8	1st pass 15Nm 2nd pass a 25Nm	Grease
Other engine nuts	M8	25Nm	
Other engine screw	M8	25Nm	
Other engine nuts	M10	40Nm	
Other engine screw	M10	40Nm	
Cylinder stud	M10	20Nm	Blue
Top dead center sight plug	M10	10Nm	Grease
Ignition nut	M12	80Nm	Blue
Water temperature sensor	M12	20Nm	Yellow
Spark plug	M14	15Nm	Copper grease
Magnetic drain plug screw	M16	15Nm	Grease
Primary gear/crankshaft nut	M20	120Nm	Blue
Water connection	M20	15Nm	Yellow
Clutch basket nut	M22	100Nm	Blue
Ignition casing cap	M27	15Nm	Grease



TIGHTENING TORQUES

Emergency stop button screw	M3	3Nm	
Spoke nut	M4	5Nm	
Battery screw (Factory)	M4	7Nm	
Master cylinder cover screw	M4	7Nm	
Odometer screw	M4	5Nm	Blue
Rear light screw	M4	1Nm	Blue
Frame protection screw	M4	2Nm	
Other frame nuts	M4	5Nm	
Other frame screw	M4	5Nm	
Other frame nuts	M5	7Nm	
Other frame screw	M5	7nm	
Air filter support nut	M5	10Nm	
Kickstand return plate	M5	7Nm	Blue
Filter flap screw	M5	7Nm	Blue
Gas control screw	M5	10Nm	
Light switch screw	M5	7Nm	
Brake pedal end screw	M5	7Nm	Blue
Fork air bleed screw	M5	3Nm	
Regulator screw	M5	8Nm	Blue
Brake hose support screw	M5	7Nm	Blue
Hand protection support screw	M5	10Nm	
Expansion tank screw	M5	10Nm	Blue
Other frame nuts	M6	10Nm	
Other chassis screw	M6	10Nm	
Starter lug nut	M6	7Nm	
Battery screw (Racing)	M6	10Nm	
Odometer support screw	M6	10Nm	Blue
Front mudguard screw	M6	12Nm	Blue
Chain guide screw	M6	12Nm	Blue
Lower bashplate screw	M6	8Nm	Blue
Rear master cylinder screw	M6	8Nm	
Clutch master cylinder screw	M6	10Nm	
Front brake master cylinder scre	M6	10Nm	
Radiator side panel screw (tank)	M6	3Nm	
Chain guide pad screw	M6	8nm	Blue
Chain protection screw	M6	10Nm	
Fork protection screw	M6	8Nm	Blue
Chain sprocket protection screw	M6	12Nm	Blue
Brake pedal stop adjustment screw	M6	8Nm	
Brake pedal adjustment screw	M6	8Nm	
Relay screw, starter relay lug	M6	6Nm	
Selector screw	M6	12Nm	Blue
Screw silent block exhaust	M6	10Nm	Blue
Mud flap support screw	M6	12Nm	Blue

TIGHTENING TORQUES

Seat lock screw	M6	10Nm	Blue
Other frame nuts	M8	25Nm	
Other chassis screw	M8	25Nm	
Valve nut	M8	8Nm	
Gripster nut	M8	12Nm	
Upper sub frame nut	M8	25Nm	
Chain tensioner nut	M8	25Nm	
Handlebar clamp screw	M8	20Nm	Cooper grease
Sprocket screw	M8	30Nm	
Steering stop screw	M8	25Nm	Blue
Brake disc screw	M8	35Nm	Red
Front brake caliper screw	M8	25Nm	Cooper grease
Frame chain guide screw	M8	25Nm	Blue
Lower sub frame screw	M8	25Nm	Blue
Fork foot screw	M8	20Nm	Cooper grease
Steering column clamp screw	M8	25Nm	Cooper grease
Front caliper bleed screw	M8	10Nm	
Chain rollers screw	M8	25Nm	Blue
Cylinder head support screw	M8	25Nm	Blue
Lower triple clamp screw	M8	12Nm	Cooper grease
Upper triple clamp screw	M8	17Nm	Cooper grease
Other engine nuts	M10	40Nm	
Other engine screw	M10	40Nm	
Engine axle	M10	60Nm	
Shock absorber foot axle	M10	50Nm	
Upper shock absorber axle	M10	50Nm	
Kickstand nut	M10	25Nm	
Brake hose banjo bolt	M10	25Nm	
Brake pedal screw	M10	25Nm	
Handlebar support screw	M10	40Nm	Red
Delta link axle	M12	60Nm	
H link axel	M12	60Nm	
H-link-chassis axle	M12	60Nm	
Swing arm axle	M16	100Nm	
Front wheel axle nut	M20	60Nm	Cooper grease
Steering column nut screw	M20	30Nm	
Rear wheel nut	M24	100Nm	Grease
Hose guide screw	Parker	2Nm	
Headlight switch screw (Racing)	Parker	2nm	
Hand guard screw	Parker	3Nm	
Mud flap support screw	Parker	3Nm	
Fan screw	Auto-perforante	3nm	
Clamp of tightening		7Nm	



CARBURETOR TUNING

» SE 250- CARBURETOR SETTING TABLE

Sea level	Temp	-20°C→ -7°C	-6°C→ 5°C	6°C→ 15°C	16°C→ 24°C	25°C→ 36°C	37°C→ 49°C
3.000 m (10,000f ft) to 2.301 m (5,001 ft)	Air adjust screw	1T ¼	1T ¾	1T ¾	2T ¼	2T ¼	
	Idling jet	40	40	38	38	35	
	Needle	N1EG	N1EG	N1EH	N1EH	N1EI	
	Position	3	2	2	2	2	
	Main jet	165	162	160	160	158	
2 300 m (7,500 ft) to 1 501 m (5,001 ft)	Air adjust screw	1T ¼	1T ¼	1T ¾	1T ¾	2T ¼	2T ¼
	Idling jet	40	40	40	38	38	35
	Needle	N1EG	N1EG	N1EG	N1EH	N1EH	N1EI
	Position	3	3	2	2	2	2
	Main jet	165	165	162	160	160	158
1 500 m (5,00 ft) to 751 m (2,501 ft)	Air adjust screw	1T	1T ¼	1T ¼	1T ¾	1T ¾	2T ¼
	Idling jet	42	42	40	40	38	38
	Needle	N1EF	N1EG	N1EG	N1EG	N1EH	N1EH
	Position	3	3	3	2	2	2
	Main jet	168	165	165	162	160	158
750 m (2,500 ft) to 301 m (1,001 ft)	Air adjust screw	1T	1T	1T ¼	1T ¼	1T ½	1T ¾
	Idling jet	48	45	45	40	40	38
	Needle	N1EF	N1EF	N1EG	N1EG	N1EG	N1EH
	Position	4	3	3	3	2	2
	Main jet	170	168	165	162	162	160
300 m (1000 ft) to 0 m 0 ft	Air adjust screw	1T	1T	1T	1T ¼	1T ¼	1T ¾
	Idling jet	45	45	42	42	42	40
	Needle	N1EE	N1EF	N1EF	N1EG	N1EG	N1EG
	Position	4	4	3	3	3	2
	Main jet	172	170	168	165	165	162

CARBURETOR TUNING

SE 300-CARBURETOR SETTING TABLE

Seal level	Temp	-20°C→ -7°C	-6°C→ 5°C	6°C→ 15°C	16°C→ 24°C	25°C→ 36°C	37°C→ 49°C
3.000 m (10,000f ft) to 2.301 m (5,001 ft)	Air adjust screw	1T ½	1T ½	2T	2T ½	3T	3T
	Idling jet	40	38	35	35	32	32
	Needle	N8RE	N8RF	N8RF	N8RG	N8RG	N8RH
	Position	3	3	3	3	3	3
	Main jet	165	162	162	160	160	158
2 300 m (7,500 ft) to 1 501 m (5,001 ft)	Air adjust screw	1T	1T ½	1T ½	2T	2T ½	3T
	Idling jet	40	38	38	35	35	32
	Needle	N8RE	N8RE	N8RF	N8RF	N8RG	N8RG
	Position	3	3	3	3	3	3
	Main jet	168	165	165	165	162	162
1 500 m (5,00 ft) to 751 m (2,501 ft)	Air adjust screw	1T	1T	1T ½	1T ½	2T	2T ½
	Idling jet	40	40	40	38	38	38
	Needle	N8RD	N8RE	N8RE	N8RF	N8RF	N8RG
	Position	3	3	3	3	2	1
	Main jet	170	168	165	165	162	160
750 m (2,500 ft) to 301 m (1,001 ft)	Air adjust screw	1T	1T	1T	1T ½	1T ½	2T
	Idling jet	42	40	40	40	40	38
	Needle	N8RD	N8RD	N8RE	N8RE	N8RF	N8RF
	Position	3	3	3	3	3	3
	Main jet	172	170	168	165	165	165
300 m (1000 ft) to 0 m 0 ft	Air adjust screw	1T	1T	1T	1T	1T ½	1T ½
	Idling jet	45	42	42	40	40	40
	Needle	N8RC	N8RD	N8RD	N8RE	N8RE	N8RF
	Position	3	3	3	3	3	3
	Main jet	175	172	170	168	165	165

WIRING DIAGRAM

» Main harness (Ref: 7107)

Description

002	Light switch
1010	Starter
1020B	Alternator
1020C	Regulator
1042	Main relay
1135	Ignition coil
1225	Actuator
1303	Ignition relay
1320	Engine ECU
1405	Crankshaft sensor
1510	Fan
4020	Temperature sensor
8235A	Starter switch (Relay)
8235B	Starter switch (Battery)
8235C	Starter (Engine)
8235D	Starter switch engine
9901	Map switch
9902	Kill switch
BB00A	Battery
C001A	Diagnostic plug
C001B	Diagnostic plug
FUSE	Fuse 15A
MM01	Ground
BB00B	Battery ground

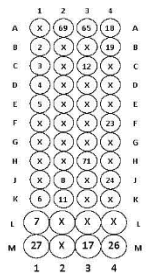
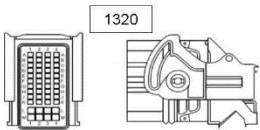

CODE COULEUR	
FR	GB
BA	Blanc White
BE	Bleu Blue
GR	Gris Grey
JN	Jaune Yellow
MR	Marron Brown
NR	Noir Black
OR	Orange Orange
RG	Rouge Red
RS	Rose Pink
VE	Vert Green
VI	Violet Violet
VJ	Vert/Jaune Green/Yellow

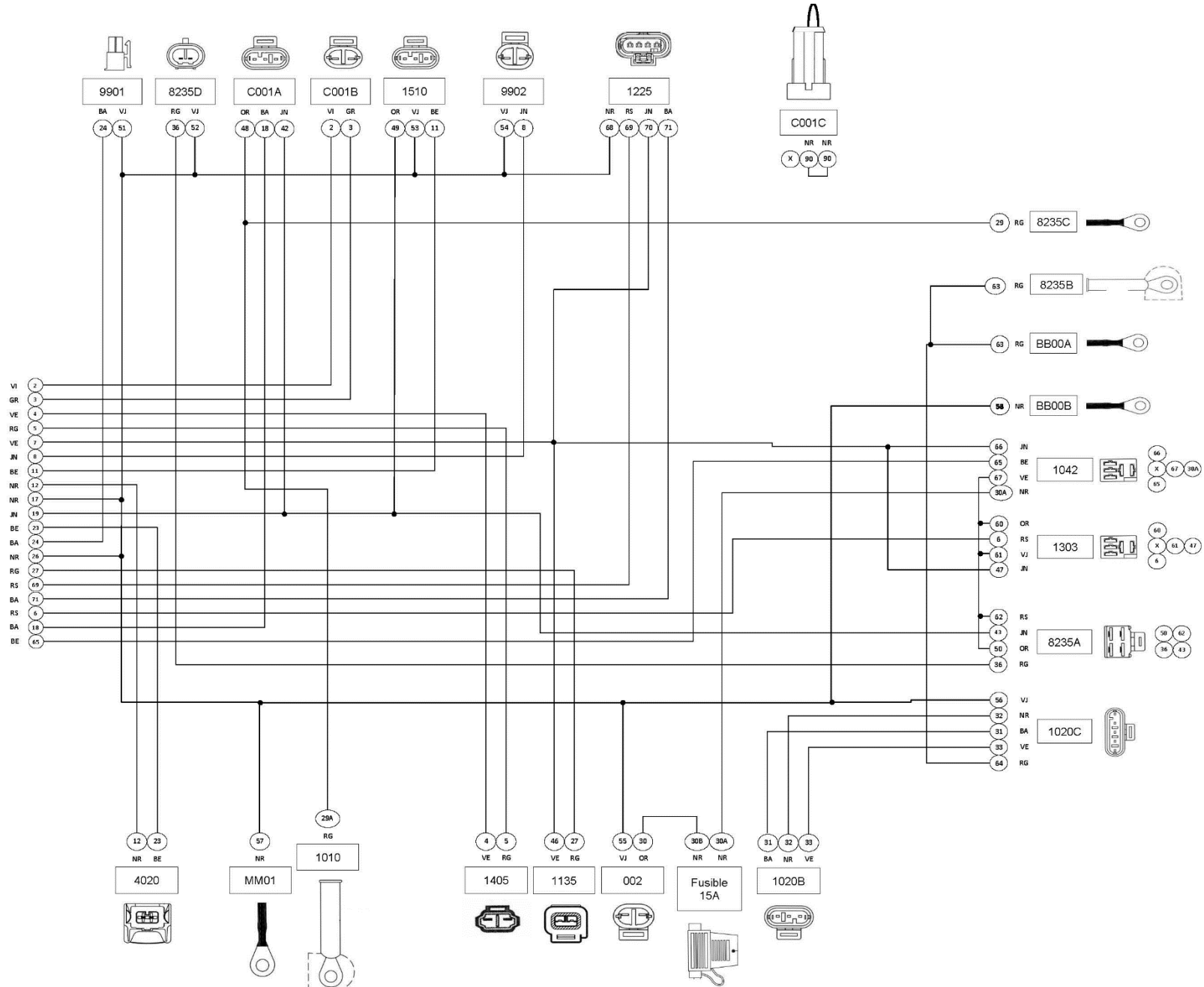

WIRING DIAGRAM

Homologated light diagram (Ref: 8145)

description

- 002 Light signal switch
- 2100 Stop switch
- 2110 Brake light
- 2305 Indicative light relay
- 2310 Headlight switch
- 2310A Light switch
- 2320 Front left indicator light
- 2320A Front left indicator light (ground)
- 2325 Front right indicator light
- 2325A Front right indicator light (ground)
- 2330 Rear left indicator light
- 2330A Rear left indicator light (ground)
- 2335 Rear right indicator light
- 2335A Rear right indicator light (ground)
- 2500 Rear brake light switch
- 2520 Hom
- 2520A Hom (ground)
- 2610 Projector
- 2630 Rear light
- 2630A Light (ground)
- 2633 Police plate light
- 2633A Police plate light (ground)
- 8235 Engine starter switch
- 9902 Kill switch
- V262 Headlight light
- V430 Fuel light
- V824 EFI light
- V824A EFI light (ground)

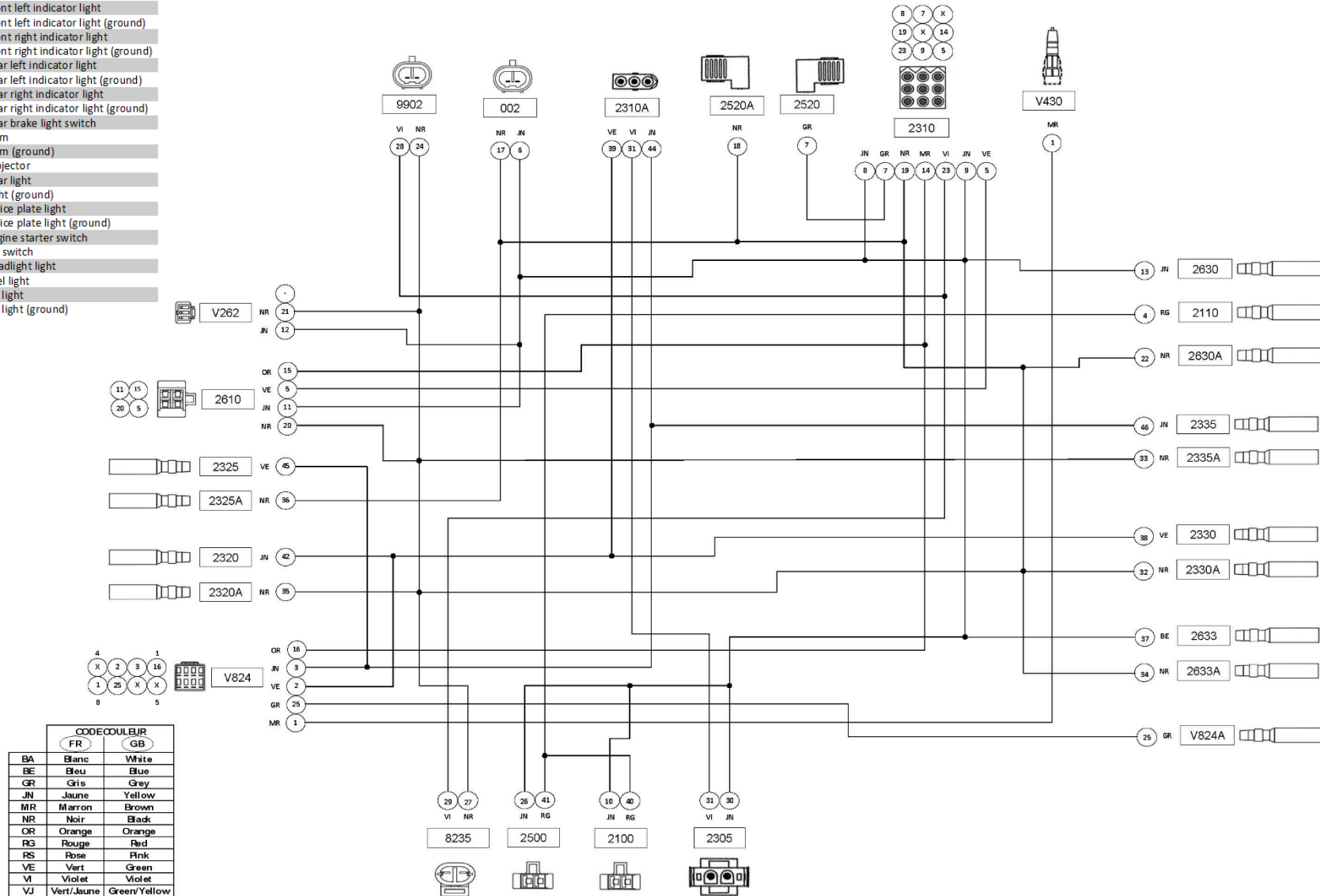

CODE COULEUR		
	FR	GB
BA	Blanc	White
BE	Bleu	Blue
GR	Gris	Grey
JN	Jaune	Yellow
MR	Marron	Brown
NR	Noir	Black
OR	Orange	Orange
RG	Rouge	Red
RS	Rose	Pink
VE	Vert	Green
VI	Violet	Violet
VJ	Vert/Jaune	Green/Yellow

WIRING DIAGRAM

»I Racing light diagram (Ref: 6845)

description

002	Light signal switch
2100	Stop switch
2110	Brake light
2610	Projector
2630	Rear light
2630A	Light (ground)
BB10	Alimentation
V262	Headlight light
V430	Fuel light
V824	EFI light
V824A	EFI light (ground)

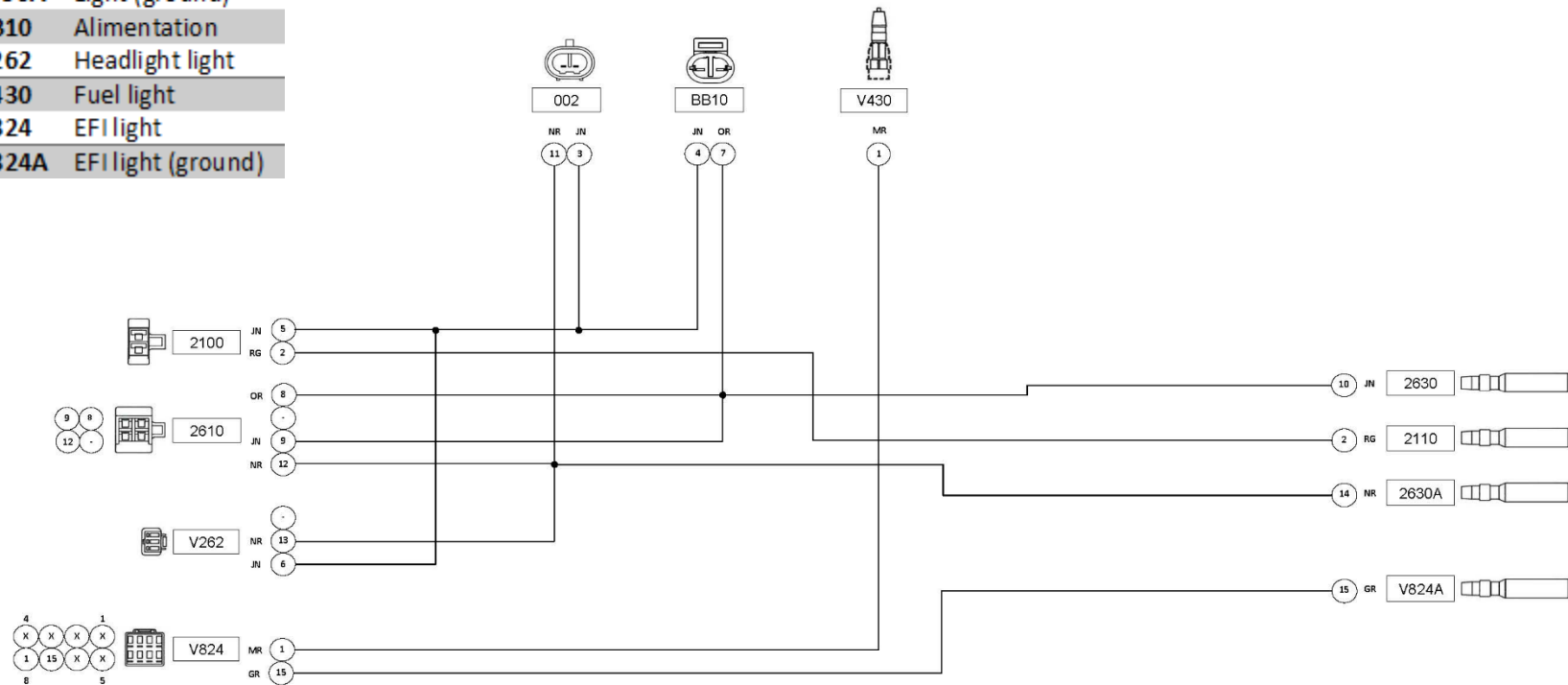

CODE COULEUR		
	FR	GB
BA	Blanc	White
BE	Bleu	Blue
GR	Gris	Grey
JN	Jaune	Yellow
MR	Marron	Brown
NR	Noir	Black
OR	Orange	Orange
RG	Rouge	Red
RS	Rose	Pink
VE	Vert	Green
VI	Violet	Violet
VJ	Vert/Jaune	Green/Yellow

WIRING DIAGRAM

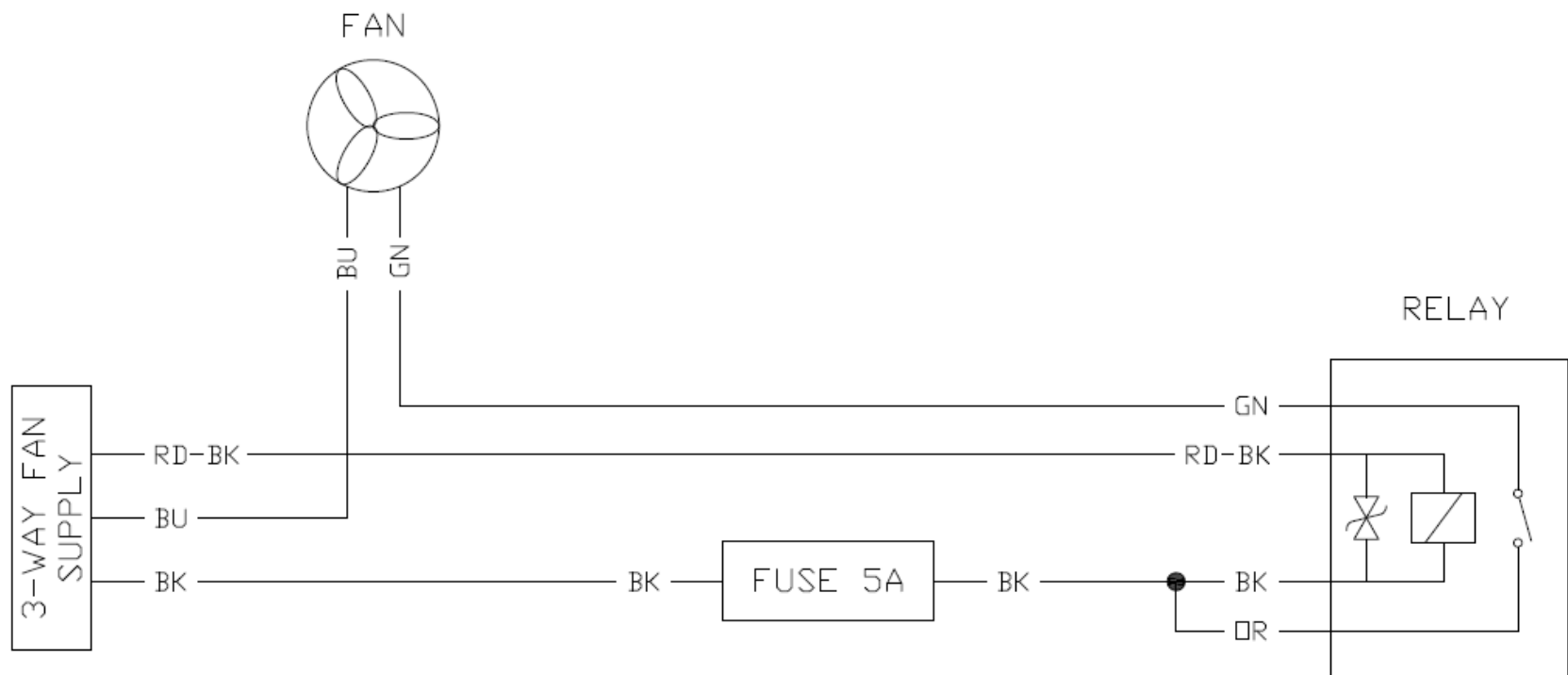

COLOR CODE	
RD	RED/ROUGE
BU	BLUE/BLEU
GN	GREEN/VERT
PK	PINK/ROSE
BK	BLACK/NOIR
OR	ORANGE/DRANGE

WWW.SHERCO.COM



MOTUL

KENNY



GAERNE

KYB
Technical Touch



Polisport
Performance Plastics

VERTEX
PISTON & POWER



GALFER

BS
BATTERY



AKRAPOVIČ

SHERCO