

SHERCO

MANUEL D'ATELIER | WORKSHOP MANUAL | MANUAL DE TALLER



SUMMARY

[Specification](#).....P3

[Cylinder Head](#).....P4 to P11

[Camshaft and Rocker Arms](#).....P12 to P15

[Valves and Valve Springs](#).....P26 to P23

[Cylinder and Piston](#).....P24 to P30

[Clutch and Primary Driven Gear](#).....P31 to 39

[Oil Pump](#).....P40 to P43

[Kick Axle and Shift Shaft](#).....P44 to 48

[CDI Magneto](#).....P49 to 51

[CDI Magneto and Starter Clutch](#).....P52 to 56

[Crankcase, Crankshaft and Balancer](#).....P57 to 63

[Transmission, Shift Cam and Shift Fork](#).....P64 to 69

[Electrical Components and wiring diagram](#).....P70 to 72

TECHNICAL INFORMATION

DIMENSIONS

Overall length	2.025 mm
Overall width	810 mm
Seat height	700 mm
wheelbase	1.308 mm
Ground clearance	320 mm
Dry weight	78 kg

MOTEUR

Engine	4 stroke SOHC Engine Euro4
Cylinder capacity	123,7
Bore x stroke	54 x 54 mm
Lubrication cylinder	Unleaded petrol , cyl. Nickasil coating
Alimentation System	Carburetor Ø 20 mm
Cooling	By air
Starting	Gear system with folding pedal (kick) / starter electric
Transmission	5-speed sequential gearbox
Clutch	Multidisc in oil bath
Ignition	Electronic CDI

PARTIE CYCLE

Frame	Monohull
Exhaust	Steel + aluminum
Petrol tank	Plastic tank 2,6 liters
Protection disk	Equal (7075), with treatment T6
Front suspension	Hydraulic telescopic fork. Diameter 40 mm and stroke 177 mm.
Rear suspension	Shock absorber R16V adjustable in compression, and pre-charge Spring stroke 165 mm
Front brake	Floating hydraulic disc 182 mm, AJP caliper 4 pistons
Rear brake	Hydraulic disc 150 mm, AJP caliper 2 pistons
Wheels	Rims in light anodized titanium alloy MORAD, 1,60"x21" and 2,15"x19"
Tires	Front tubetype tire, rear tubeless tire

CYLINDER HEAD

CYLINDER HEAD

CYLINDER HEAD SIDE COVER AND TAPPET COVER

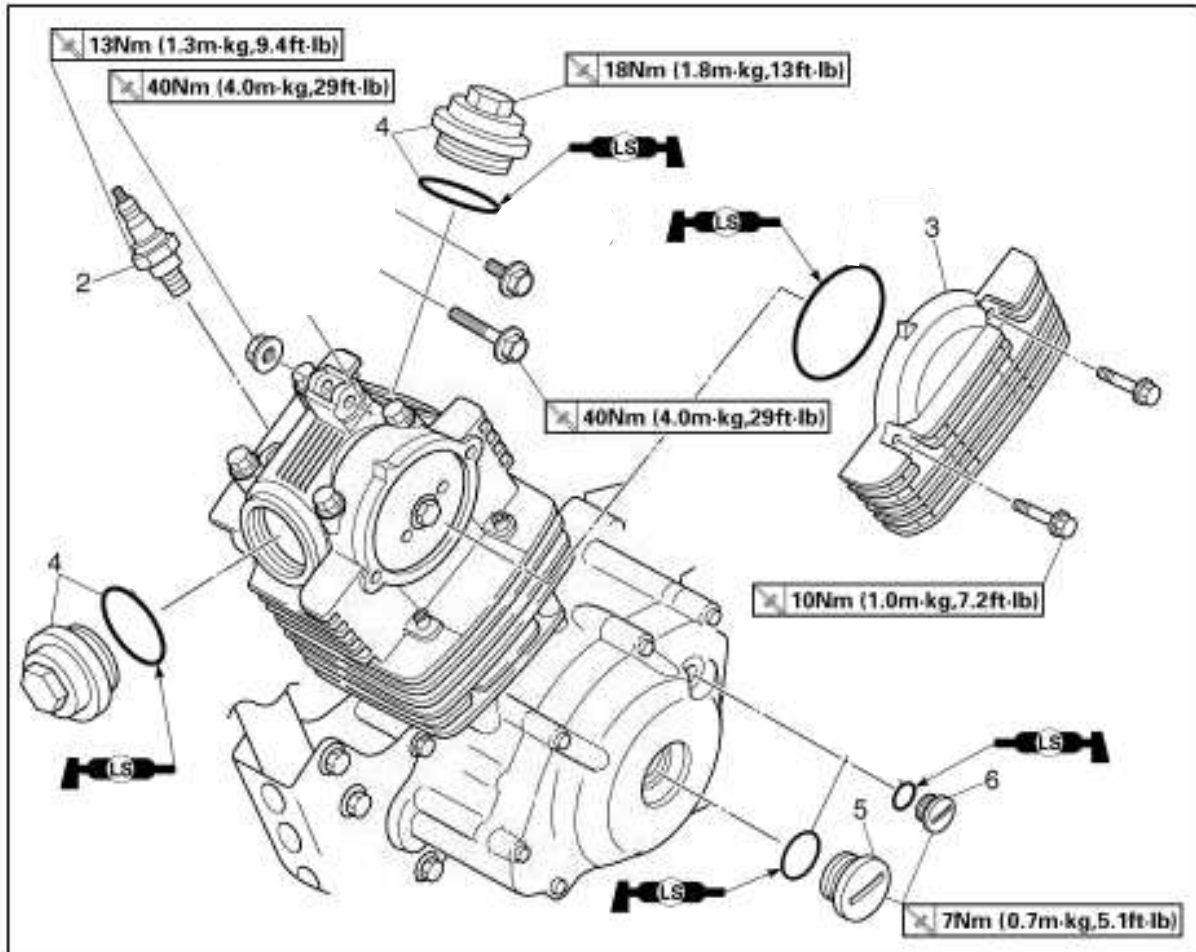

CYLINDER HEAD

CYLINDER HEAD

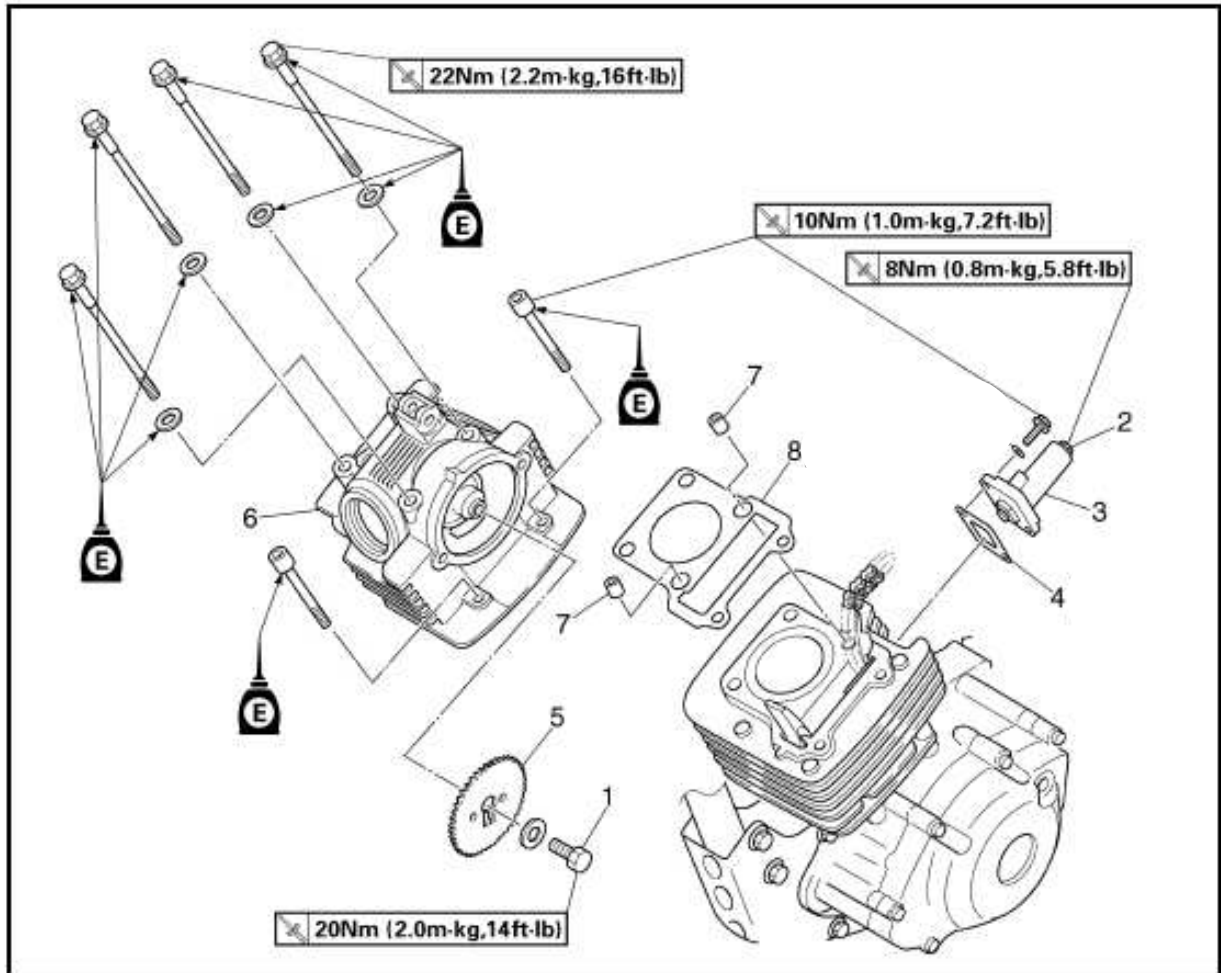

CYLINDER HEAD

REMOVAL POINTS

Cylinder head

1. Align:
 - "I" mark (with stationary pointer)

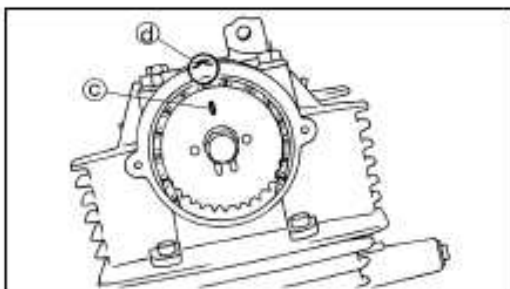
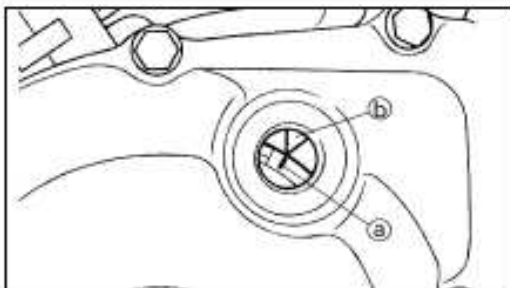

Checking steps:

- Turn the crankshaft counterclockwise with a wrench.
- Align the "I" mark (b) on the rotor with the stationary pointer (a) on the crankcase cover. When the "I" mark is aligned with the stationary pointer, the piston is at the Top Dead Center (T.D.C.).

NOTE:

In order to be sure that the piston is at Top Dead Center, the match mark (c) on the camshaft sprocket must align with the stationary pointer (d) on the cylinder head as shown in the illustration.

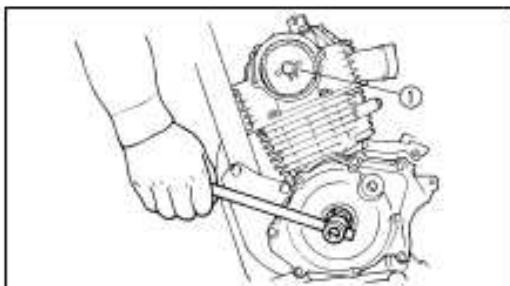

2. Loosen:
 - Camshaft sprocket bolt (1)

NOTE:

Remove the bolt while holding the rotor nut with a wrench.

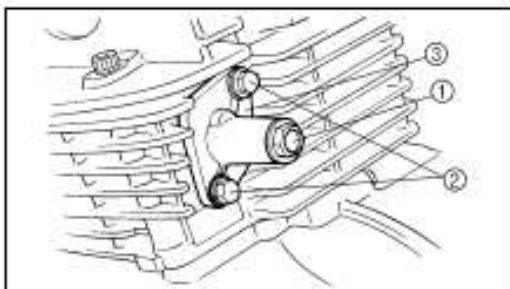

3. Remove:
 - Bolt (timing chain tensioner cap) (1)
 - Bolt (timing chain tensioner) (2)
 - Timing chain tensioner (3)

TECHNICAL INFORMATION

CYLINDER HEAD

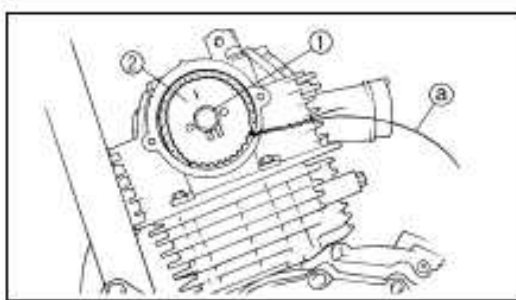

4. Remove:
 - Bolt (camshaft sprocket) ①
 - Camshaft sprocket ②

NOTE: Attach a wire ③ to the timing chain to prevent it from falling into the crankcase.

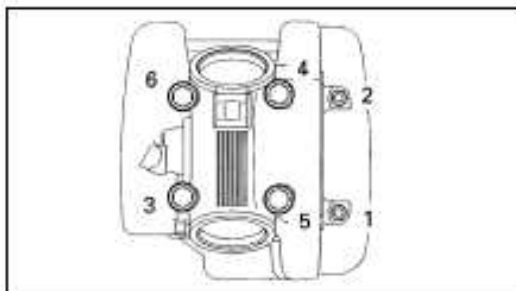

5. Remove:
 - Bolts (cylinder head)
 - Cylinder head

NOTE:

- Loosen the bolts 1/4 turn each and remove then after all are loosened.
- Loosen the bolts starting with the lowest number one.

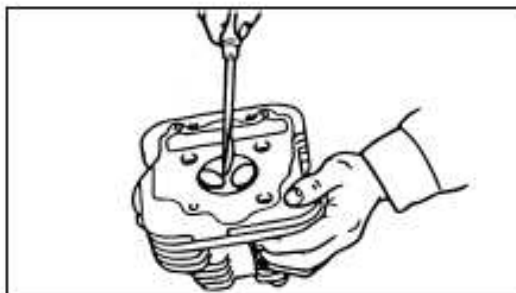

INSPECTION

Cylinder head

1. Eliminate:
 - Carbon deposits (from the combustion chambers)
 Use a rounded scraper.

NOTE: Do not use a sharp instrument to avoid damaging or scratching:

- Spark plug threads
- Valve seats

2. Inspect:
 - Cylinder head
 Scratches/damage → Replace.

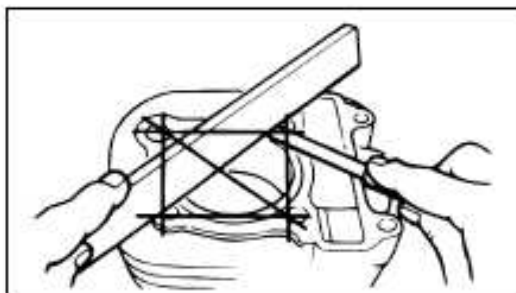

3. Inspect:
 - Cylinder head warpage
 Out of specification → Re-surface.

Warpage measurement and re-surfacing steps:

- Attach a straightedge and a thickness gauge on the cylinder head.
- Measure the warpage.

TECHNICAL INFORMATION

CYLINDER HEAD

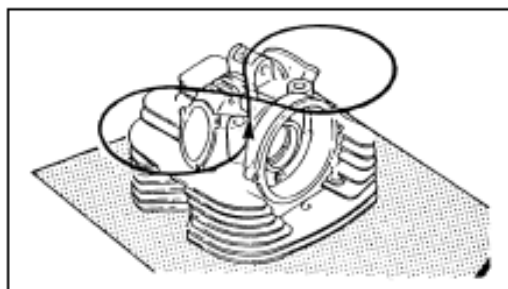

Warpage limit:
0.03 mm (0.0012 in)

- If the warpage is out of specification, resurface the cylinder head.
- Place #400 - 600 grit wet sandpaper on the surface plate, and re-surface the head using a figure-eight sanding pattern.

NOTE:

Rotate the cylinder head several times to avoid removing too much material from one side.

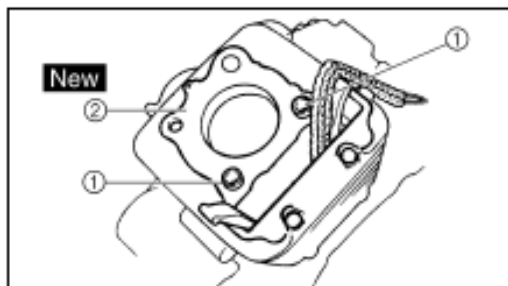

ASSEMBLY AND INSTALLATION

Cylinder head

1. Install:
 - Dowel pin ①
 - Gasket ② **New**

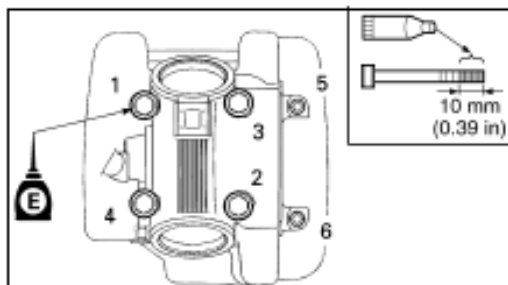

2. Install:
 - Cylinder head
 - Copper washer
 - Bolt (cylinder head)

M8	22 Nm (2.2 m - kg, 16 ft - lb)
M6	10 Nm (1.0 m - kg, 7.2 ft - lb)

CYLINDER HEAD

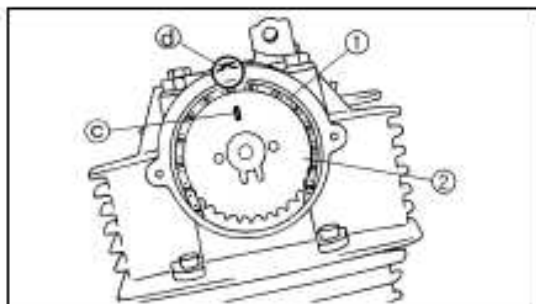
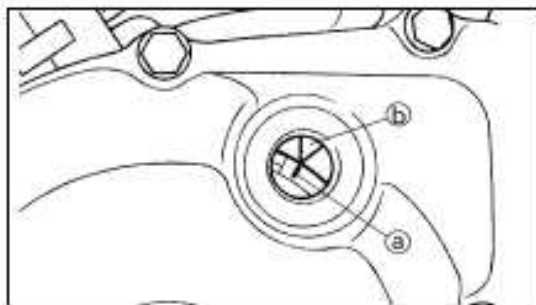

3. Install:
- Timing chain
 - Camshaft sprocket

Installation steps:

- Turn the crankshaft counterclockwise with a wrench.
- Align the "T" mark (a) on the rotor with the stationary pointer (b) on the crankcase cover.
- Align the match mark (c) on the camshaft sprocket with the stationary pointer (d) on the cylinder head.
- Fit the timing chain (1) onto camshaft sprocket (2) and install the camshaft sprocket on the camshaft.

NOTE:

When installing the camshaft sprocket, keep the timing chain as tense as possible on the exhaust side.

CAUTION:

Do not turn the crankshaft during installation of the camshaft. Damage or improper valve timing will result.

- Remove the safety wire from the timing chain.

4. Install:
- Washer
 - Bolt (camshaft sprocket)

NOTE:

Temporarily tighten the bolt (camshaft sprocket) at this point.

TECHNICAL INFORMATION

CYLINDER HEAD

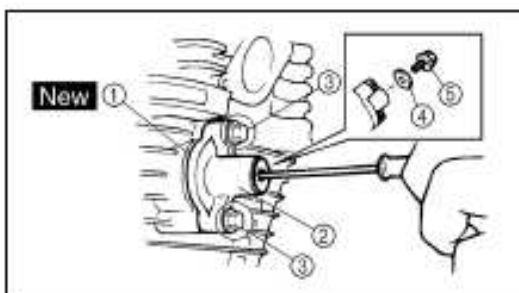
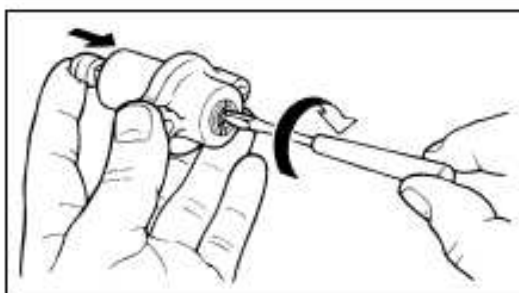

5. Install:
- Timing chain tensioner

Installation steps:

- While pressing the tensioner rod lightly with fingers, use a thin screwdriver and wind the tensioner rod up fully clockwise.
- With the rod fully wound, install the gasket (1) and the chain tensioner (2), and tighten the bolts (3) to the specified torque.



Bolt (chain tensioner):
10 Nm (1.0 m • kg, 7.2 ft • lb)

- Release the screwdriver, check the tensioner rod to come out and tighten the gasket (4) and the cap bolt (5) to the specified torque.



Cap bolt (timing chain tensioner):
8 Nm (0.8 m • kg, 5.8 ft • lb)

6. Turn:
- Crankshaft
Counterclockwise several turns
7. Check:
- Rotor "I" mark
Align with the crankcase stationary pointer.
 - Camshaft match mark
Align with the cylinder head stationary pointer.
Out of alignment → Adjust.

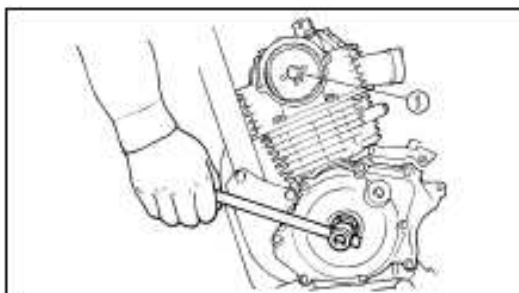

8. Tighten:
- Bolt (1)

20 Nm (2.0 m • kg, 14 ft • lb)

NOTE:
Tighten the bolt while holding the rotor nut with a wrench.

CYLINDER HEAD

9. Check:
- Valve clearance
Out of specification → Adjust.
Refer to "VALVE CLEARANCE INSPECTION AND ADJUSTMENT"

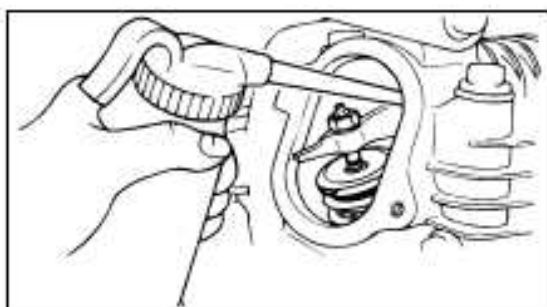

10. Apply:
- Engine oil
On camshaft.

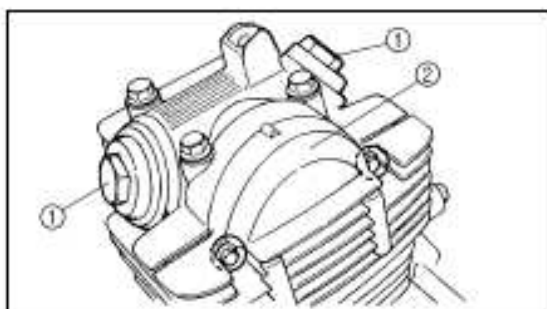

11. Install:
- Tappet cover ①
18 Nm (1.8 m · kg, 13 ft · lb)
 - Cylinder head side cover ②
10 Nm (1.0 m · kg, 7.2 ft · lb)

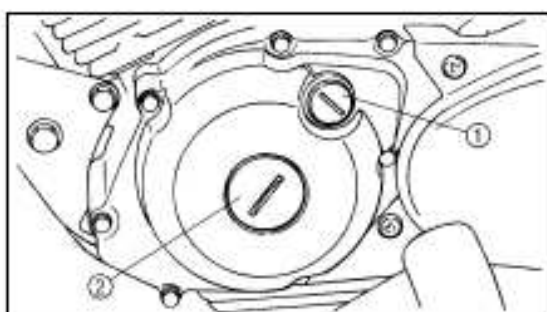

12. Install:
- Timing mark accessing screw ①
7 Nm (0.7 m · kg, 5.1 ft · lb)
 - Crankshaft end accessing screw ②
7 Nm (0.7 m · kg, 5.1 ft · lb)

13. Install:
- Spark plug
13 Nm (1.3 m · kg, 9.4 ft · lb)
 - Engine bracket
40 Nm (4.0 m · kg, 29 ft · lb)

CAMSHAFT AND ROCKER ARMS

CAMSHAFT AND ROCKER ARMS

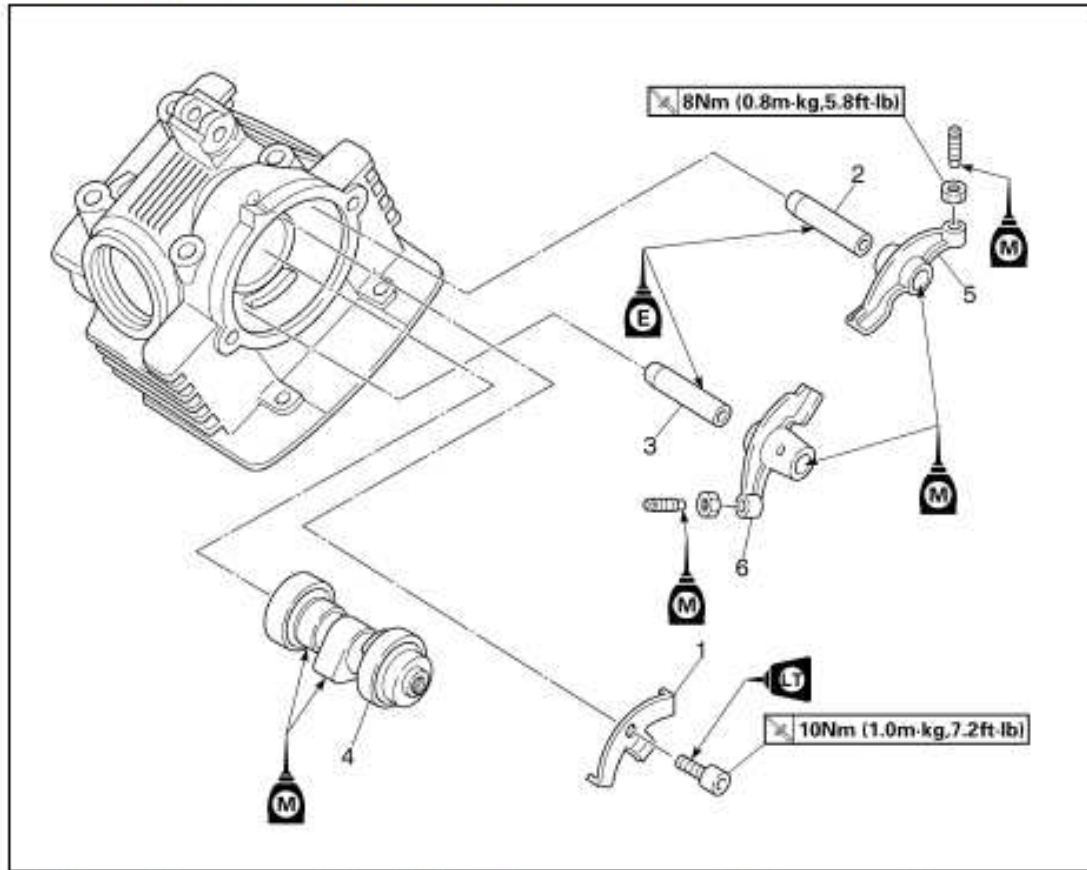

TECHNICAL INFORMATION

CAMSHAFT AND ROCKER ARMS

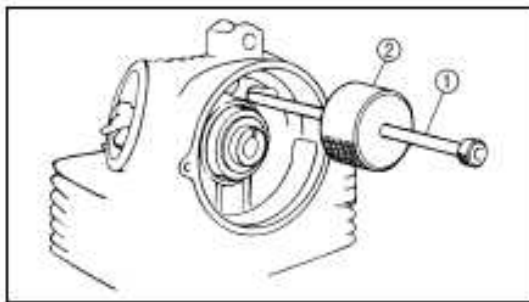

REMOVAL POINTS

Rocker arm shaft

1. Remove:
 - Rocker arm shafts

NOTE:

Use a slide hammer bolt ① and weight ② to slide out the rocker arm shafts.

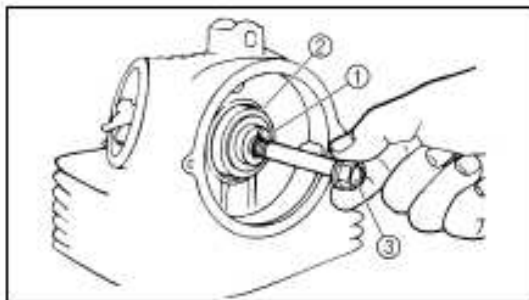

Camshaft

1. Remove:
 - Camshaft ①
 - Camshaft bearing ②

NOTE:

Screw in a suitable length of 8 mm bolt ③ into the threaded end of the camshaft and pull out the camshaft.

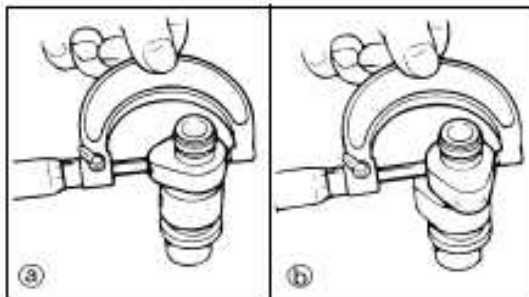

INSPECTION

Camshaft

1. Inspect:
 - Cam lobes
Pitting/scratches/blue discoloration → Replace.
2. Measure:
 - Cam lobes length ③ and ④
Out of specification → Replace.

	Cam lobes length limit:
	Intake: ③ 25.851 mm (1.0178 in) ④ 21.165 mm (0.8333 in) Exhaust: ③ 25.811 mm (1.0162 in) ④ 21.020 mm (0.8276 in)

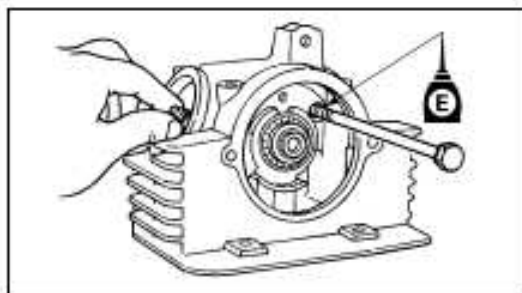
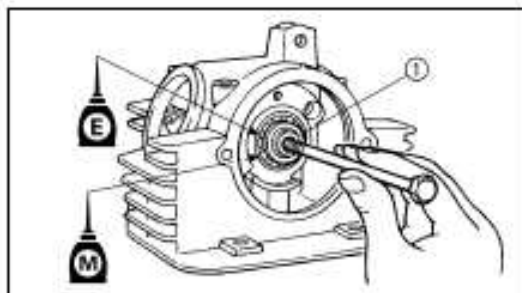
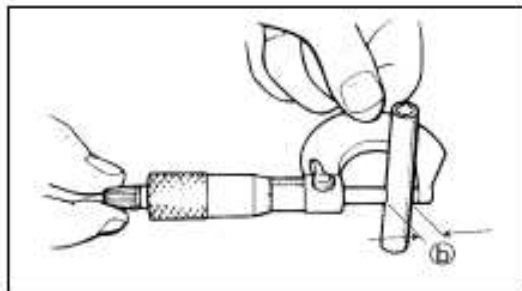
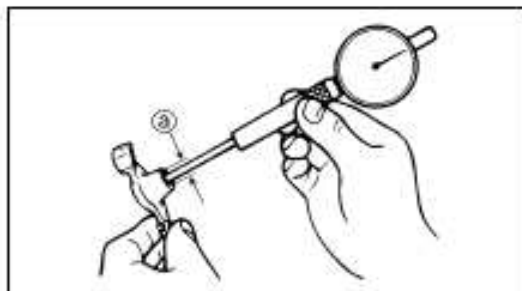
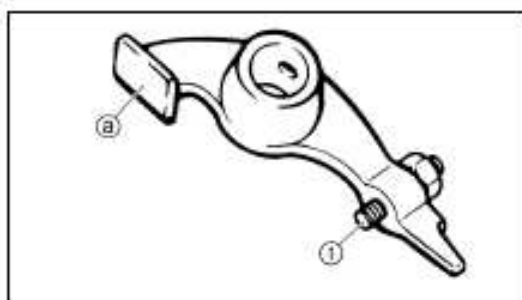

TECHNICAL INFORMATION

CAMSHAFT AND ROCKER ARMS



Rocker arms and rocker arm shafts

1. Inspect:
 - Cam lobe contact surface (a)
 - Adjuster surface (i)
 Wear/pitting/scratches/blue discoloration → Replace.

Measurement steps:	
<ul style="list-style-type: none"> • Measure the inside diameter (a) of the rocker arm holes. Out of specification → Replace.	
	Inside diameter (rocker arm): 10.000 - 10.015 mm (0.3937 - 0.3943 in) <Limit>: 10.03 mm (0.3949 in)
<ul style="list-style-type: none"> • Measure the outside diameter (b) of the rocker arm shafts. Out of specification → Replace.	
	Outside diameter (rocker arm shaft): 9.981 - 9.991 mm (0.3930 - 0.3933 in) <Limit>: 9.95 mm (0.3917 in)

ASSEMBLY AND INSTALLATION

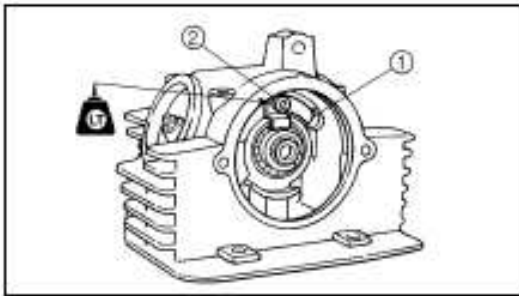

1. Apply:
 - Molybdenum disulfide oil (onto the camshaft cam lobe and rocker arm hole)
 - Engine oil (onto the camshaft bearing)
2. Install:
 - Rocker arms
 - Camshaft (i)
3. Apply:
 - Engine oil (onto the rocker arm shaft)
4. Install:
 - Rocker arm shaft

CAMSHAFT AND ROCKER ARMS

5. Install:

- Camshaft bearing holder ①

- Bolt ②

  10 Nm (1.0 m · kg, 7.2 ft · lb)

VALVES AND VALVE SPRINGS

VALVES AND VALVE SPRINGS

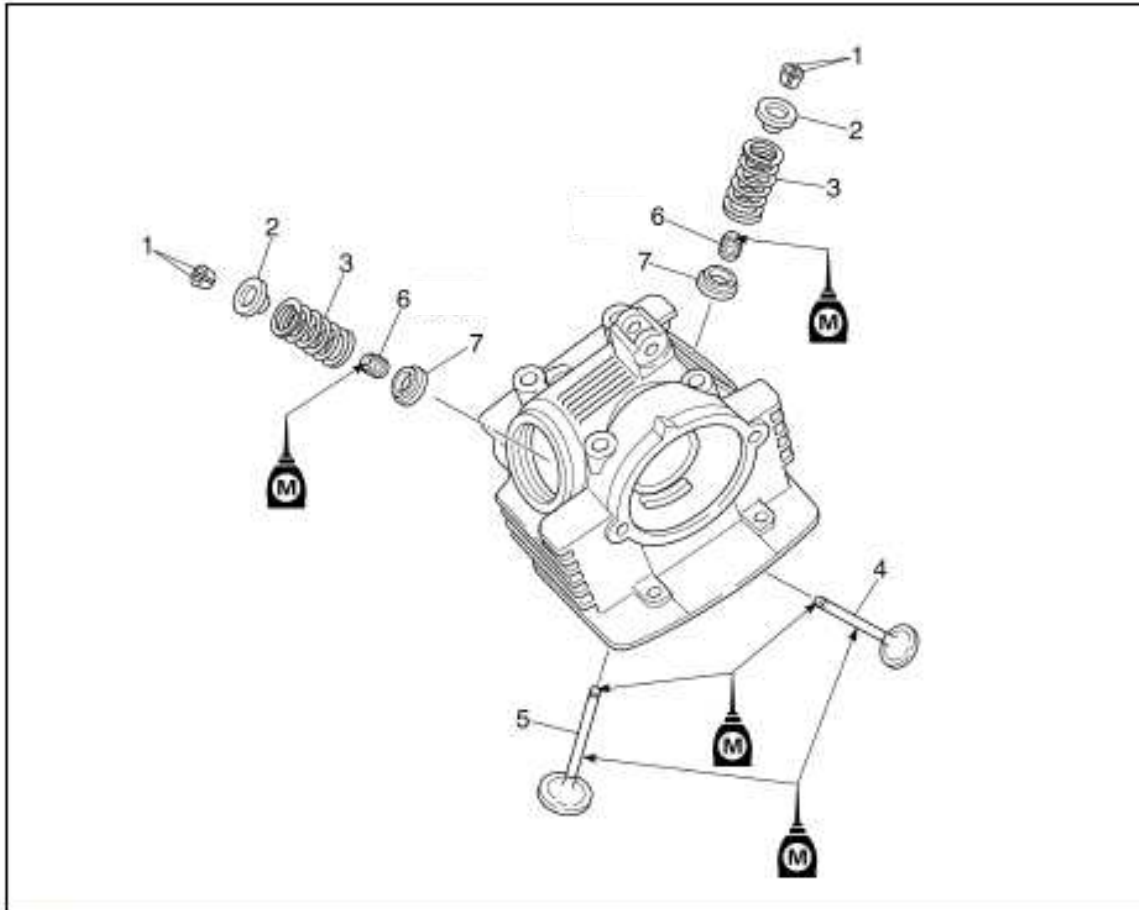

VALVES AND VALVE SPRINGS

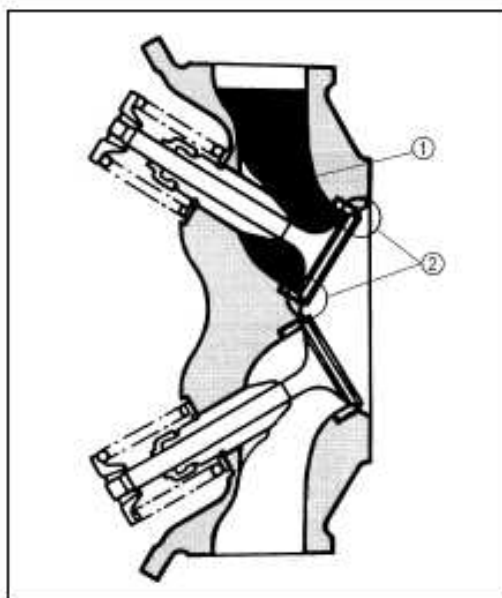

REMOVAL POINTS

Valve

1. Check:
 - Valve sealing
Leakage at the valve seat → Inspect the valve face, valve seat and valve seat width.

Checking steps:

- Pour a clean solvent ① into the intake and exhaust ports.
- Check that the valve seals properly. There should be no leakage at the valve seat ②.

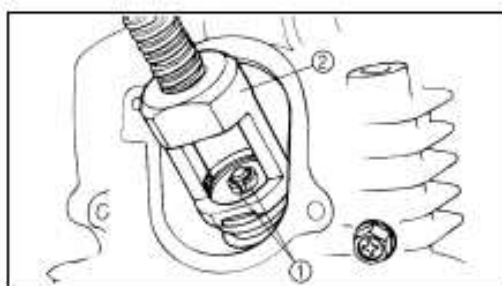

2. Remove:
 - Valve cotters ①

NOTE: Attach a valve spring compressor ② between the valve spring retainer and the cylinder head to remove the valve cotters.

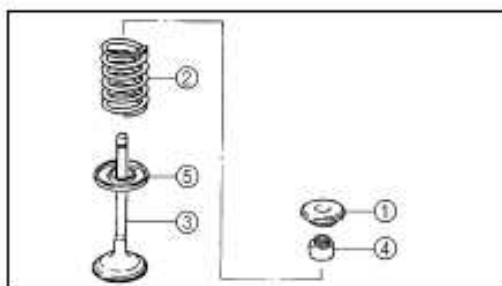

3. Remove:
 - Valve spring retainer ①
 - Valve spring ②
 - Valve ③
 - Valve stem seal ④
 - Valve spring seat ⑤

NOTE: Identify the position of each part very carefully so that it can be reinstalled in its original place.

VALVES AND VALVE SPRINGS

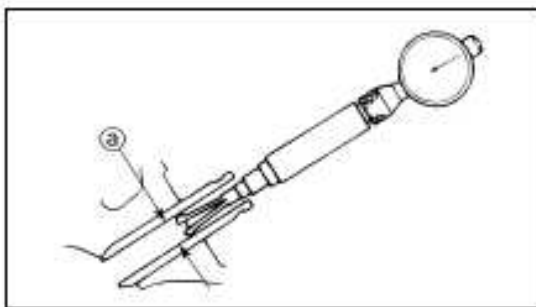

INSPECTION

Valve

1. Measure:
 - Stem-to-guide clearance

Stem-to-guide clearance =
valve guide inside diameter (a) –
valve stem diameter (b)

Out of specification → Replace the valve guide.

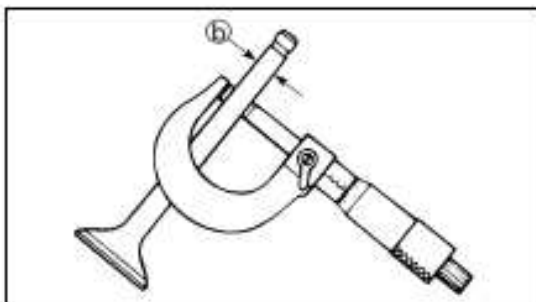

Clearance (stem to guide):
Intake:
 0.010 ~ 0.037 mm
 (0.0004 ~ 0.0015 in)
 <Limit>: 0.08 mm (0.0031 in)
Exhaust:
 0.025 ~ 0.052 mm
 (0.0010 ~ 0.0020 in)
 <Limit>: 0.10 mm (0.0040 in)



2. Replace:
 - Valve guide

Replacement steps:

NOTE: _____
 To ease guide removal, installation and to maintain correct fit heat the cylinder head in an oven to 100 °C (212 °F).

- Remove the valve guide using a valve guide remover (1).
- Install the new valve guide using a valve guide remover and valve guide installer.
- After installing the valve guide, bore the valve guide using a valve guide reamer (2) to obtain proper stem-to-guide clearance.

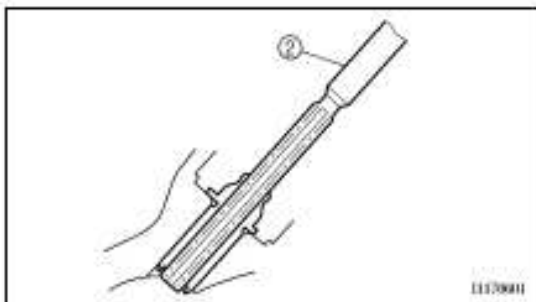

NOTE: _____
 After replacing the valve guide reface the valve seat.

VALVES AND VALVE SPRINGS

3. Inspect:
 - Valve face
Pitting/wear → Grind the face.
 - Valve stem end
Mushroom shape or diameter larger than the body of the stem → Replace.

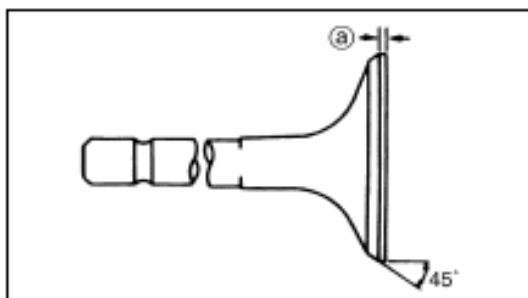

4. Measure:
 - Margin thickness @
Out of specification → Replace.

	Margin thickness:
	Intake:
	0.4 ~ 0.8 mm (0.0157 ~ 0.0315 in)
	Exhaust:
	0.8 ~ 1.2 mm (0.0315 ~ 0.0472 in)

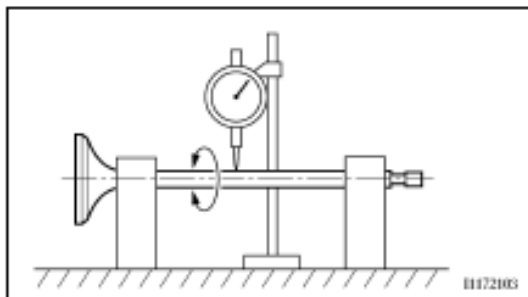

5. Measure:
 - Runout (valve stem)
Out of specification → Replace.

	Runout limit:
	0.01 mm (0.0004 in)

- NOTE:**
- When installing a new valve always replace the guide.
 - If the valve is removed or replaced always replace the oil seal.

6. Eliminate:
 - Carbon deposits
(from the valve face and valve seat)
7. Inspect:
 - Valve seats
Pitting/wear → Reface the valve seat.

VALVES AND VALVE SPRINGS

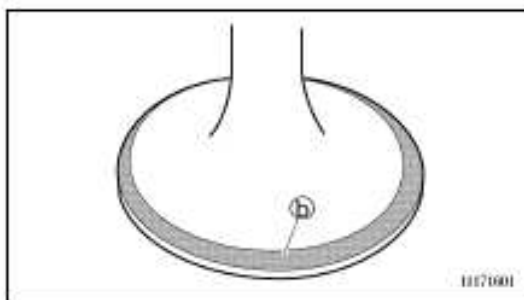
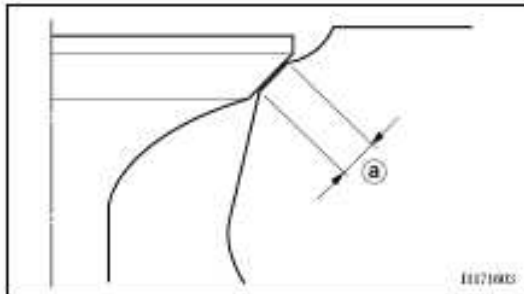

8. Measure:

- Valve seat width (a)
- Out of specification → Reface the valve seat.



Valve seat width:

Intake:

0.9 - 1.1 mm (0.0354 - 0.0433 in)

<Limit>: 1.6 mm (0.0630 in)

Exhaust:

0.9 - 1.1 mm (0.0354 - 0.0433 in)

<Limit>: 1.6 mm (0.0630 in)

Measurement steps:

- Apply Mechanic's blueing dye (Dykem) (b) to the valve face.
- Install the valve into the cylinder head.
- Press the valve through the valve guide and onto the valve seat to make a clear pattern.
- Measure the valve seat width. Where the valve seat and valve face made contact, blueing will have been removed.
- If the valve seat is too wide, too narrow, or the seat is not centered, the valve seat must be refaced.

9. Lap:

- Valve face
- Valve seat

NOTE:

After refacing the valve seat or replacing the valve and valve guide, the valve seat and valve face should be lapped.

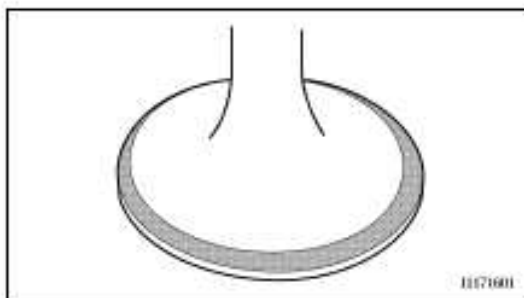

Lapping steps:

- Apply a coarse lapping compound to the valve face.

CAUTION:

Do not let the compound enter the gap between the valve stem and the valve guide.

- Apply molybdenum disulfide oil to the valve stem.

VALVES AND VALVE SPRINGS

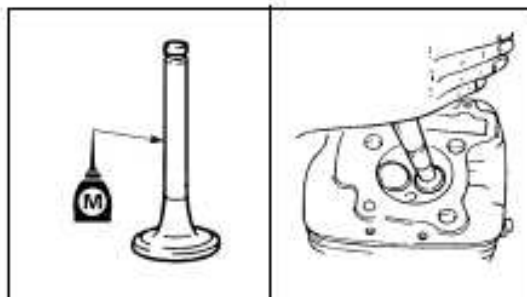

- Install the valve into the cylinder head.
- Turn the valve until the valve face and valve seat are evenly polished, then clean off all of the compound.

NOTE: _____
For best lapping results, lightly tap the valve seat while rotating the valve back and forth between your hands.

- Apply a fine lapping compound to the valve face and repeat the above steps.

NOTE: _____
After every lapping operation be sure to clean off all of the compound from the valve face and valve seat.

- Apply Mechanic's blueing dye (Dykem) to the valve face.
- Install the valve into the cylinder head.
- Press the valve through the valve guide and onto the valve seat to make a clear pattern.
- Measure the valve seat width again. If the valve seat width is out of specification, reface and re-lap the valve seat.

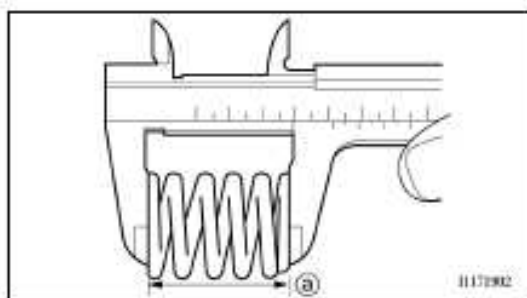

Valve spring

1. Measure:
 - Valve spring free length (a)
 - Out of specification → Replace.

	Free length (valve spring):
	Intake:
	32.55 mm (1.28 in)
	<Limit>: 31.2 mm (1.23 in)
	Exhaust:
	32.55 mm (1.28 in)
	<Limit>: 31.2 mm (1.23 in)

VALVES AND VALVE SPRINGS

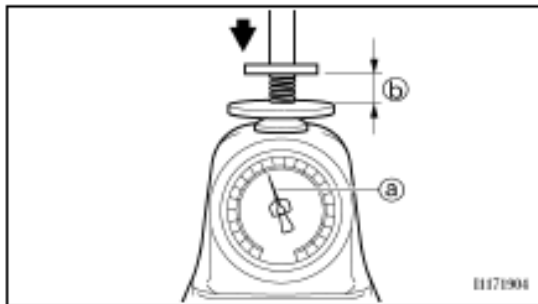

2. Measure:
- Compressed spring force **Ⓐ**
Out of specification → Replace.

Ⓑ Installed length

	Compressed spring force:
	Intake: 14.0 ~ 16.1 kg at 25.6 mm (30.86 ~ 35.49 lb at 1.01 in)
	Exhaust: 14.0 ~ 16.1 kg at 25.6 mm (30.86 ~ 35.49 lb at 1.01 in)

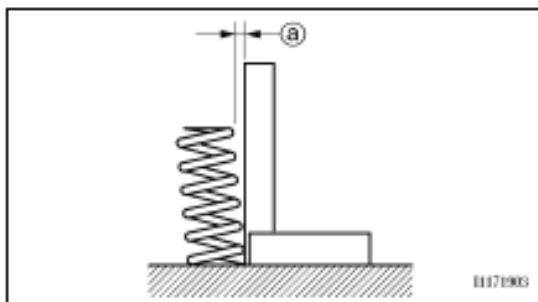

3. Measure:
- Spring tilt **Ⓐ**
Out of specification → Replace.

	Spring tilt limit:
	Intake: 2.5°/1.4 mm (0.06 in)
	Exhaust: 2.5°/1.4 mm (0.06 in)

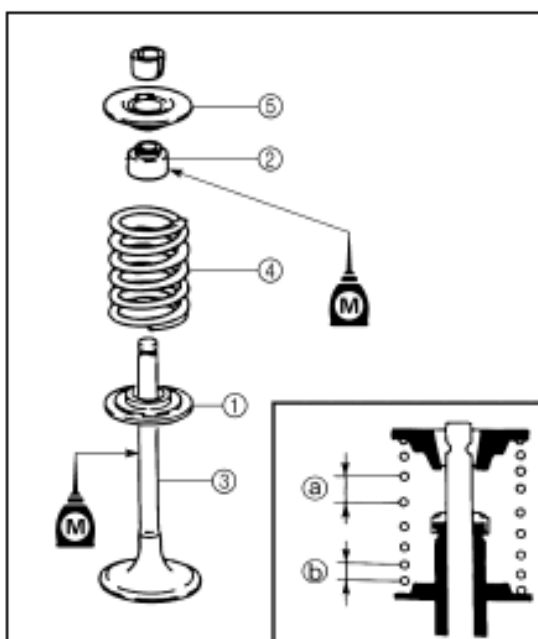

ASSEMBLY AND INSTALLATION

Valve

1. Apply:
 - Molybdenum disulfide oil
(onto the valve stem and valve stem seal)
2. Install:
 - Valve spring seats **Ⓐ**
 - Valve stem seals **Ⓑ**
 - Valves **Ⓒ**
 - Valve springs **Ⓓ**
 - Valve spring retainers **Ⓔ**

NOTE:

- Make sure that each valve is installed in its original place.
- Install the valve springs with the larger pitch **Ⓐ** facing upwards.

Ⓑ Smaller pitch

VALVES AND VALVE SPRINGS

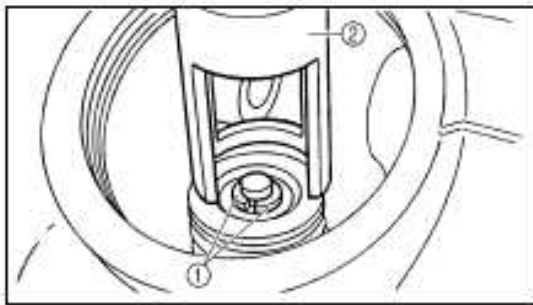

3. Install:
 - Valve cotters ①

NOTE: _____
 While compressing the valve spring with a valve spring compressor ②, install the valve cotters.

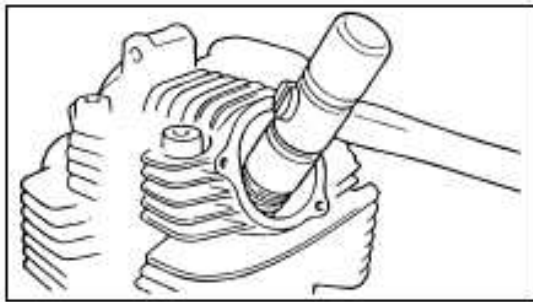

4. To secure the valve cotters onto the valve stem, lightly tap the valve tip with a piece of wood.

CAUTION: _____
 Hitting the valve tip with excessive force could damage the valve.

CYLINDER AND PISTON

CYLINDER AND PISTON

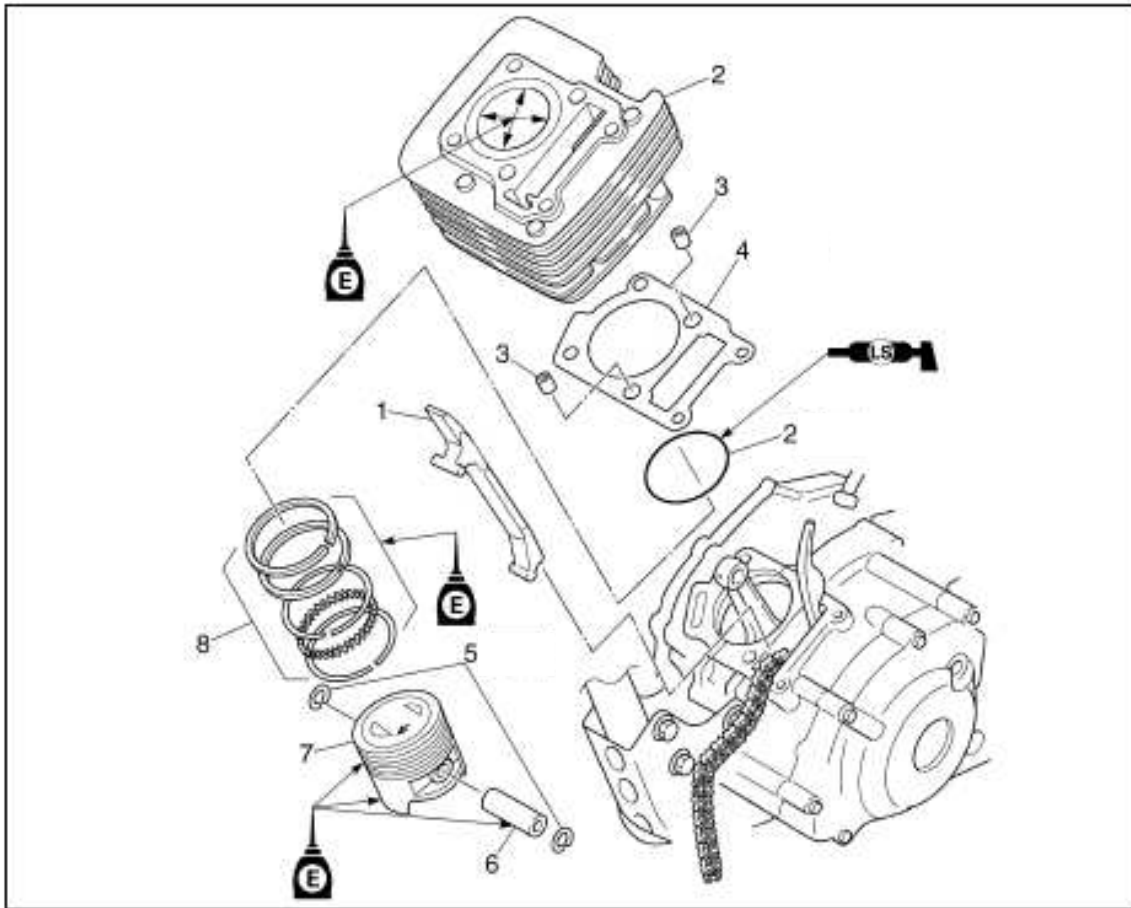

CYLINDER AND PISTON

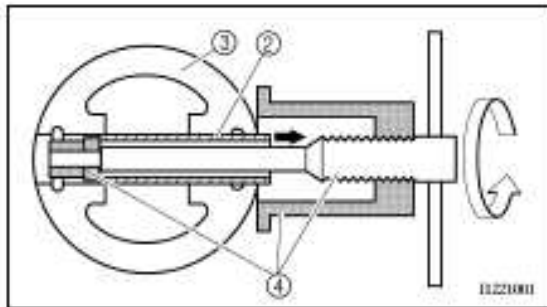
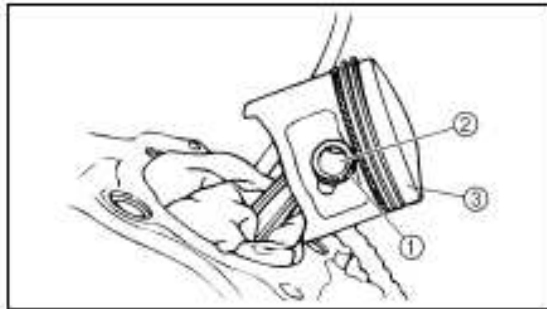

REMOVAL POINTS

Piston

1. Remove:
 - Piston pin clips ①
 - Piston pin ②
 - Piston ③

NOTE:

- Before removing the piston pin clip, cover the crankcase opening with a clean towel or rag to prevent the clip from falling into the crankcase cavity.
- Before removing each piston pin, deburr the clip groove and pin hole area. If the piston pin groove is deburred and the piston pin is still difficult to remove, use the piston pin puller ④.

CAUTION:

Do not use a hammer to drive the piston pin out.

Piston ring

1. Remove:
 - Piston rings

NOTE:

Spread the end gaps apart while at the same time lifting the piston ring over the top of the piston crown, as shown in the illustration.

INSPECTION

Cylinder and piston

1. Inspect:
 - Cylinder and piston walls
 Vertical scratches → Replace cylinder and piston.

CYLINDER AND PISTON

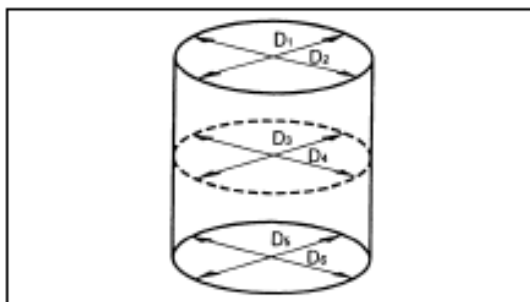

2. Measure:
- Piston-to-cylinder clearance

Piston-to-cylinder clearance measurement steps:

1st step:

- Measure the cylinder bore "C" with the cylinder bore gauge.

NOTE:

Measure the cylinder bore "C" in parallel to and at right angles to the crankshaft. Then, find the average of the measurements.

Cylinder bore "C"	54.000 ~ 54.019 mm (2.126 ~ 2.127 in)
Taper limit "T"	0.05 mm (0.002 in)
Out of round "R"	0.05 mm (0.002 in)

"C" = maximum of D₁ ~ D₆

"T" = maximum of D₁, or D₂ –
maximum of D₅ or D₆

"R" = maximum of D₁, D₃ or D₅ –
minimum of D₂, D₄ or D₆

- If out of specification, replace the cylinder, and replace the piston and piston rings as set.

2nd step:

- Measure the piston skirt diameter "P" with a micrometer.

Ⓐ 5 mm (0.20 in) from the piston bottom edge.

	Piston size P
Standard	53.977 ~ 53.996 mm (2.1251 ~ 2.1258 in)

- If out of specification, replace the piston and piston rings as a set.

3rd step:

- Calculate the piston-to-cylinder clearance with following formula.

Piston-to-cylinder clearance =
Cylinder bore "C" –
Piston skirt diameter "P"



Piston-to-cylinder clearance:
0.020 ~ 0.026 mm
(0.0008 ~ 0.0010 in)
<Limit>: 0.15 mm (0.006 in)

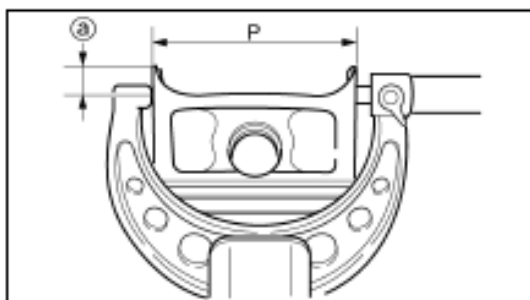

TECHNICAL INFORMATION

CYLINDER AND PISTON

- If out of specification, replace the cylinder, and replace the piston and piston rings as a set.

Piston pin

1. Inspect:

- Piston pin
Blue discoloration/grooves → Replace, then inspect the lubrication system.

2. Measure:

- Piston pin-to-piston clearance

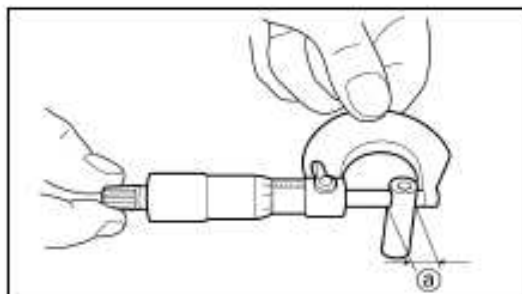

Measurement steps:

- Measure the piston pin outside diameter (a).
If out of specification, replace the piston pin.



Outside diameter (piston pin):
14.991 - 15.000 mm
(0.5902 - 0.5906 in)
<Limit>: 14.971 mm (0.5894 in)

- Measure the piston inside diameter (b).
If out of specification, replace the piston.

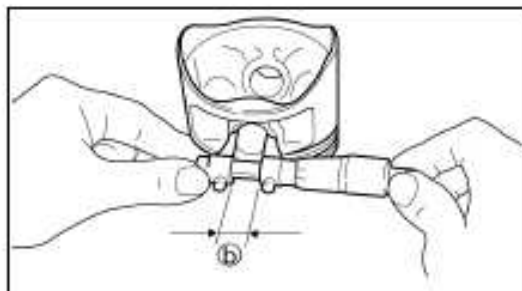

Inside diameter (piston):
15.002 - 15.013 mm
(0.5906 - 0.5911 in)
<Limit>: 15.043 mm (0.5922 in)

TECHNICAL INFORMATION

CYLINDER AND PISTON

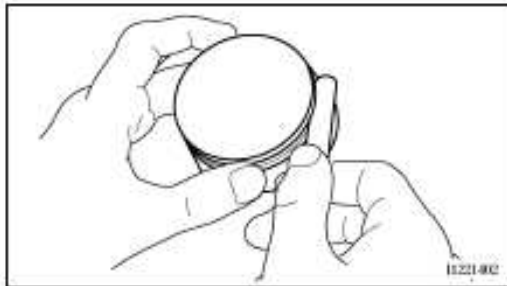

Piston ring

1. Measure:
 - Ring side clearance
Use a feeler gauge.
Out of specification → Replace the piston and rings as a set.

NOTE: Clean carbon from the piston ring grooves and rings before measuring the side clearance.

	Side clearance:	
	Standard	<Limit>
Top ring	0.035 ~ 0.090 mm (0.0014 ~ 0.0035 in)	0.12 mm (0.0047 in)
2nd ring	0.020 ~ 0.060 mm (0.0008 ~ 0.0024 in)	0.12 mm (0.0047 in)



2. Position:
 - Piston ring
(in cylinder)

NOTE: Insert a ring into the cylinder and push it approximately 40 mm (1.57 in) into the cylinder. Push the ring with the piston crown so that the ring will be at a right angle to the cylinder bore.

④ 40 mm (1.57 in)

3. Measure:
 - Ring end gap
Out of specification → Replace.

NOTE: You cannot measure the end gap on the expander spacer of the oil control ring. If the oil control ring rails show excessive gap, replace all three rings.

	End gap:	
	Standard	<Limit>
Top ring	0.15 ~ 0.30 mm (0.006 ~ 0.012 in)	0.4 mm (0.016 in)
2nd ring	0.30 ~ 0.45 mm (0.012 ~ 0.018 in)	0.55 mm (0.022 in)
Oil ring	0.20 ~ 0.70 mm (0.01 ~ 0.03 in)	—

TECHNICAL INFORMATION

CYLINDER AND PISTON

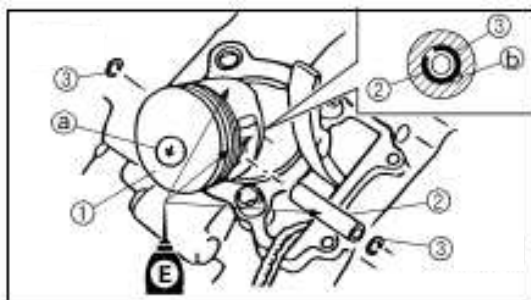
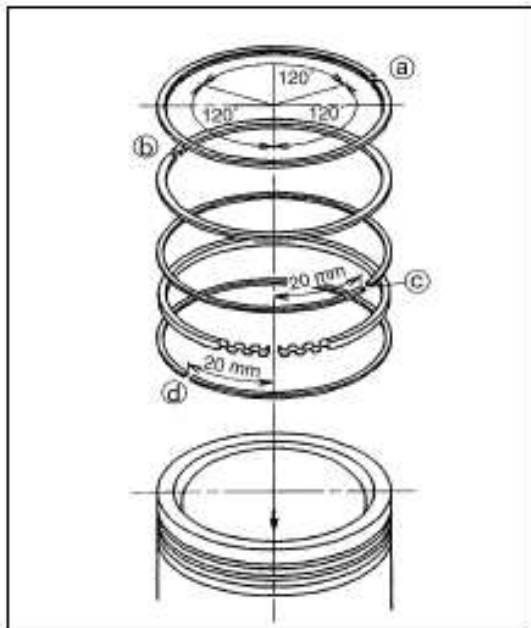
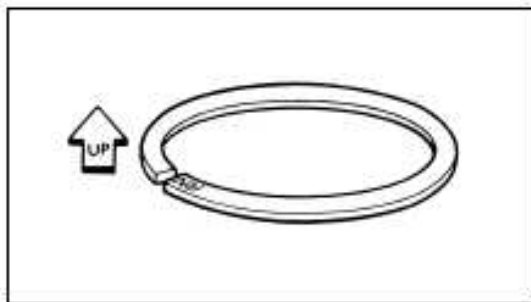

ASSEMBLY AND INSTALLATION

Piston ring and piston

1. Install:
 - Piston rings (onto the piston)

NOTE:

- Be sure to install the 2nd piston ring so that the manufacturer's mark or number are located on the upper side of the ring.
- Lubricate the piston and piston rings liberally with engine oil.

2. Position:

- Top ring
 - 2nd ring
 - Oil ring
- Offset the piston ring end gaps as shown.

- (a): Top ring end
- (b): 2nd ring end
- (c): Oil ring end (upper)
- (d): Oil ring end (lower)

3. Install:

- Piston ①
- Piston pin ②
- Piston pin clips ③

NOTE:

- Apply engine oil onto the piston pin, piston rings and piston.
- Be sure that the arrow mark (a) on the piston points to the exhaust side of the engine.
- Before installing the piston pin clip, cover the crankcase with a clean rag to prevent the piston pin clip from falling into the crankcase.
- When removing the piston pin clip, pop it out using the small opening (b).

4. Lubricate:

- Piston
- Piston rings
- Inside of cylinder

NOTE:

Apply a liberal coating of engine oil.

CYLINDER AND PISTON

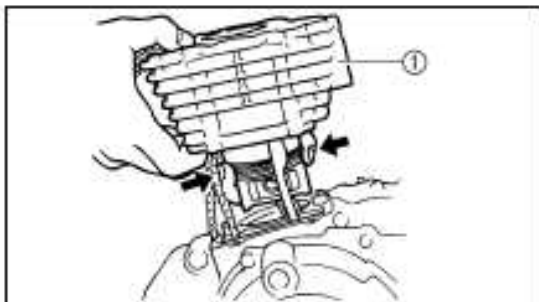
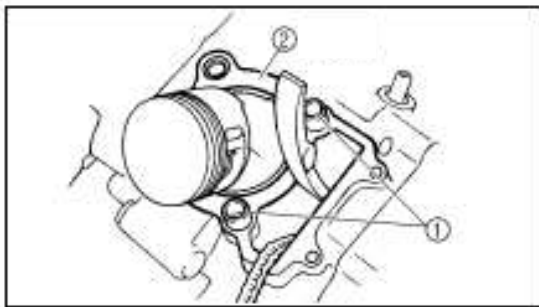

Cylinder

1. Install:
 - Dowel pins ①
 - Gasket (cylinder) ②

2. Install:
 - O-ring
 - Cylinder ①
 - Exhaust timing chain guide

CAUTION:

- Install the cylinder with one hand while compressing the piston rings with the other hand.
- Pass the timing chain through the cylinder timing chain cavity.
- Be careful not to damage the timing chain guide during installation.

NOTE:

After installing, check the smooth movement of the piston.

TECHNICAL INFORMATION

CLUTCH AND PRIMARY DRIVEN GEAR

CLUTCH AND PRIMARY DRIVEN GEAR

CLUTCH PLATE AND FRICTION PLATE

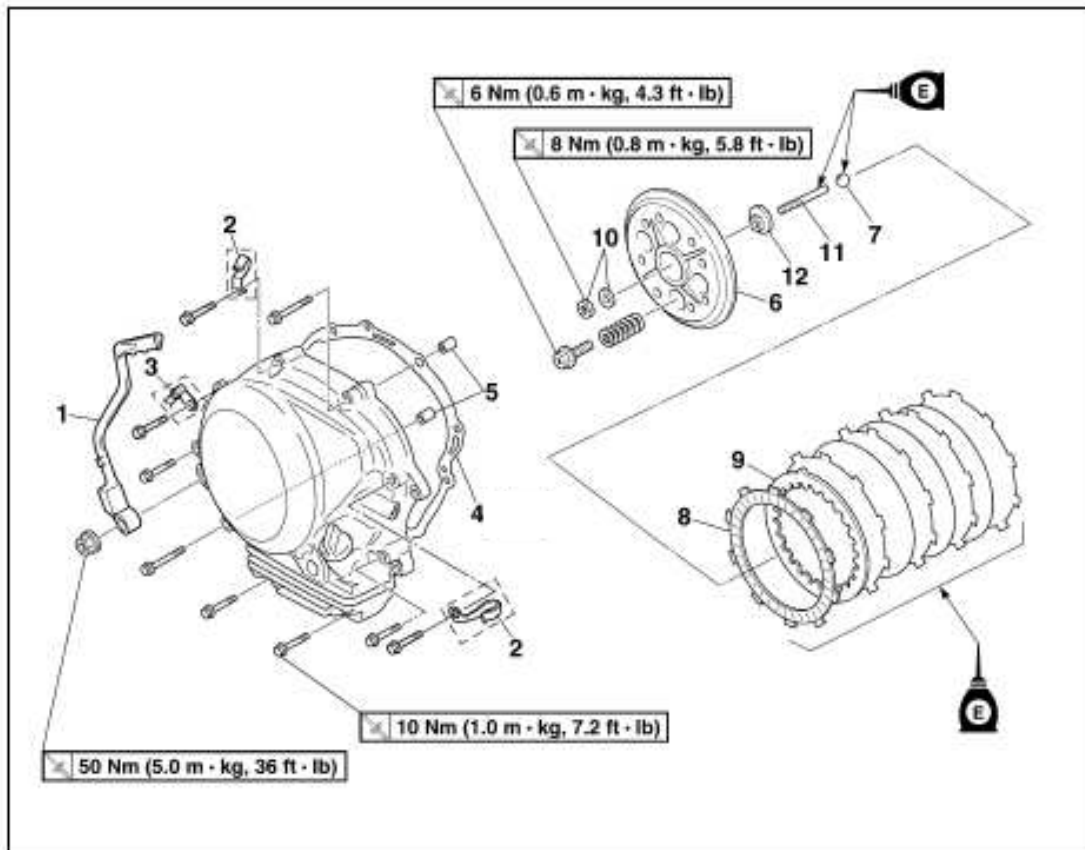

CLUTCH AND PRIMARY DRIVEN GEAR

PRIMARY DRIVEN GEAR

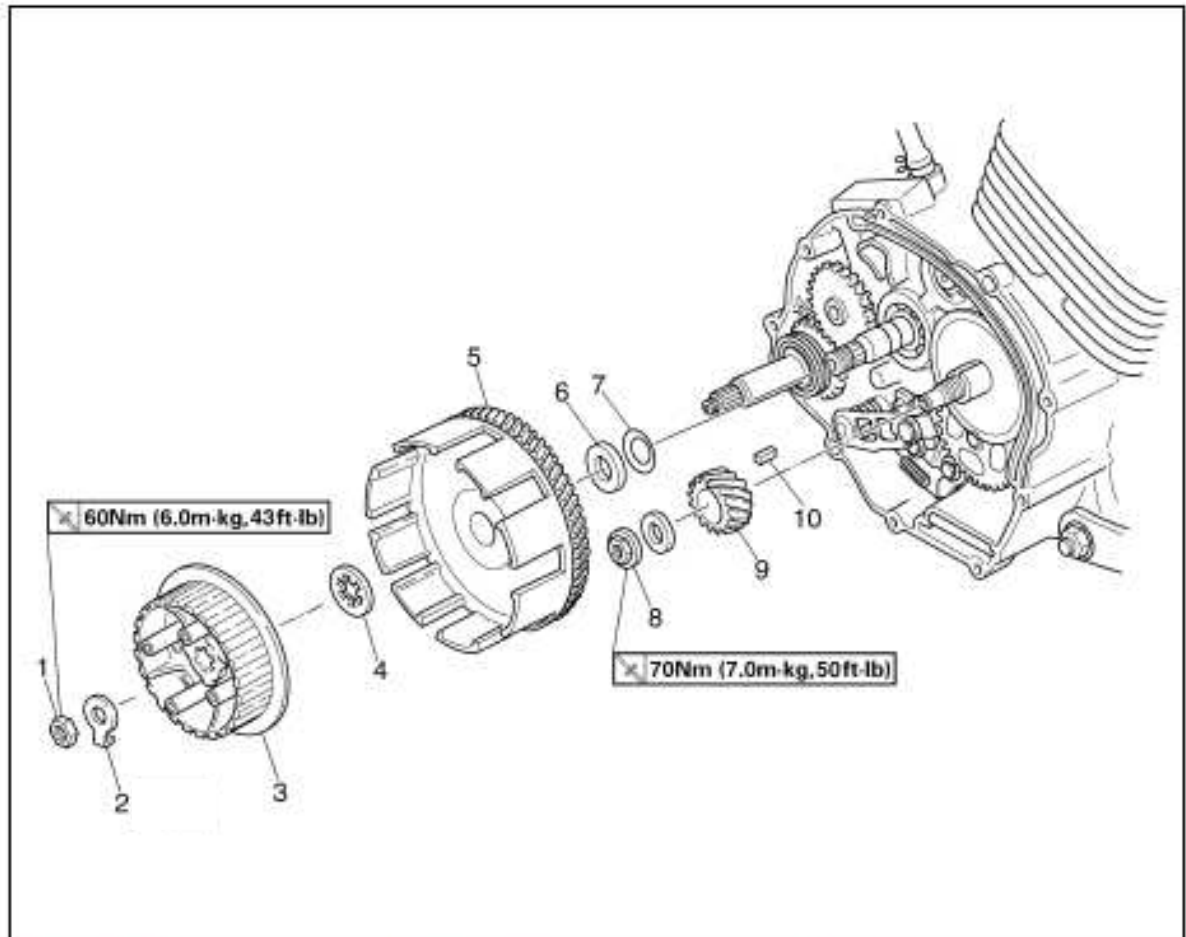

CLUTCH AND PRIMARY DRIVEN GEAR

PUSH LEVER

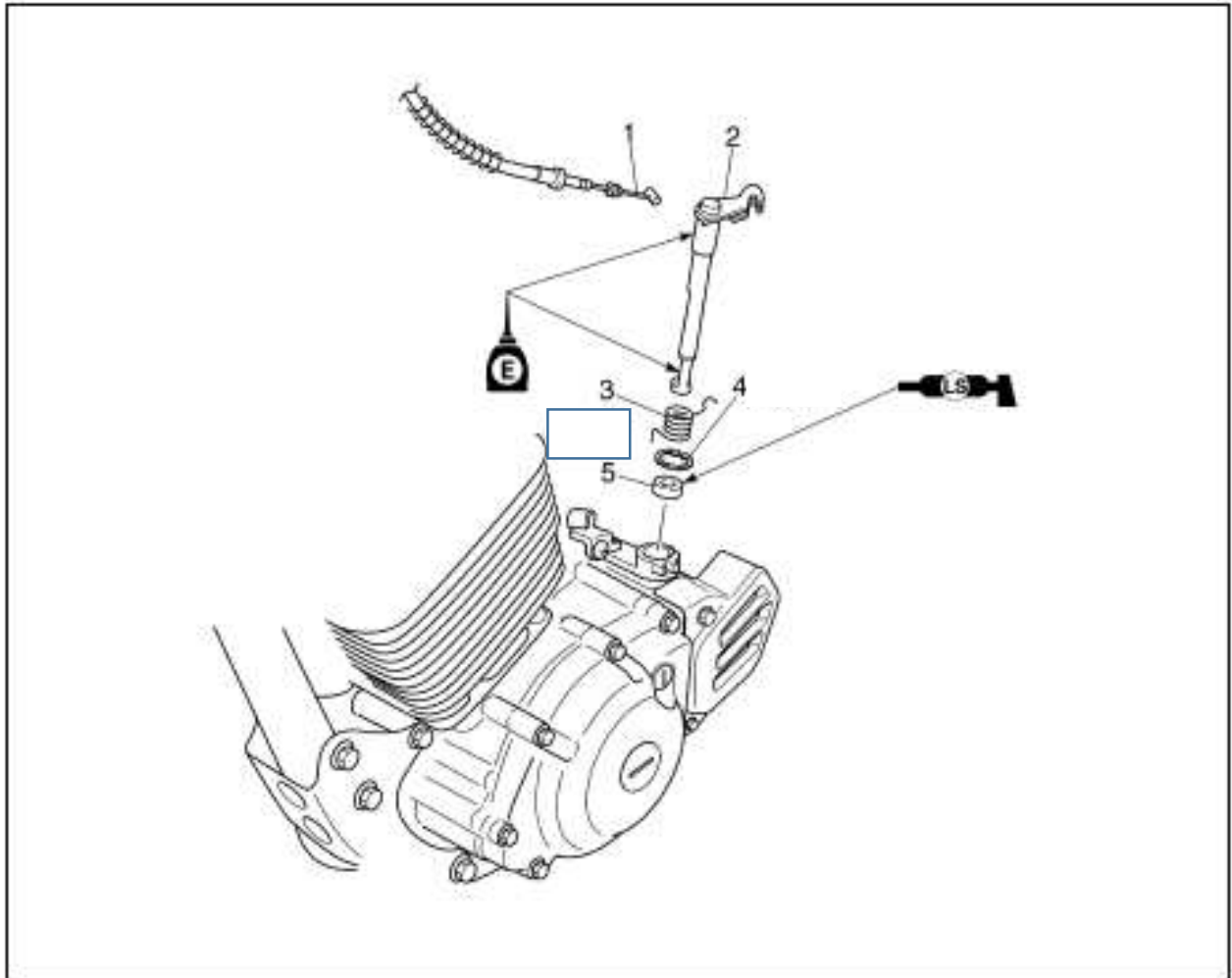

TECHNICAL INFORMATION

CLUTCH AND PRIMARY DRIVEN GEAR

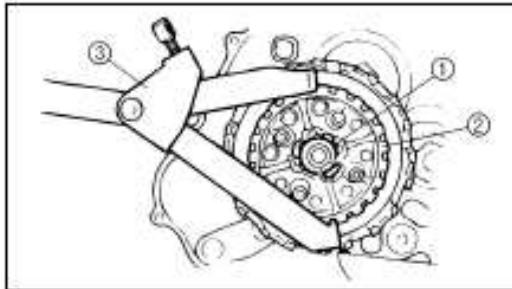

REMOVAL POINTS

Clutch boss

1. Remove:
 - Nut ①
 - Lock washer
 - Clutch boss ②

NOTE:

Straighten the lock washer tab and use the clutch holding tool ③ to hold the clutch boss.

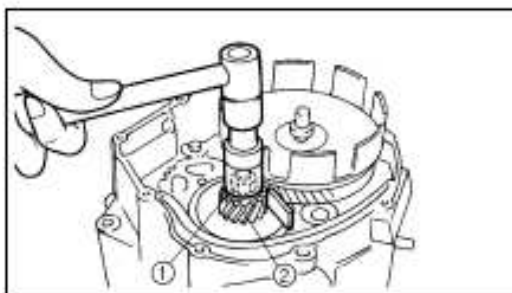
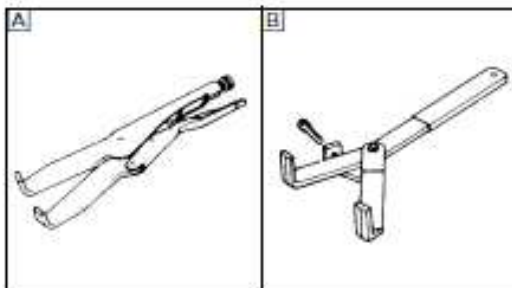

Primary drive gear

1. Remove:
 - Nut (primary drive gear) ①
 - Primary drive gear ②

NOTE:

- Place a folded rag or aluminum plate between the teeth of the primary drive gear and primary driven gear.
- Take care not to damage the gear teeth.

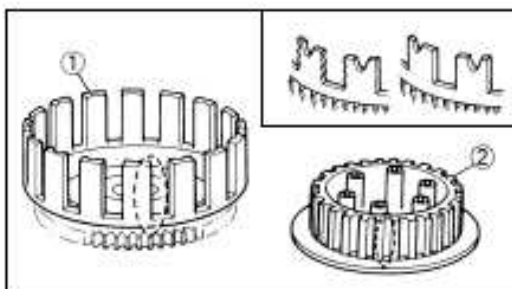

INSPECTION

Clutch housing and boss

1. Inspect:
 - Clutch housing ①
Cracks/wear/damage → Replace.
 - Clutch boss ②
Scoring/wear/damage → Replace.

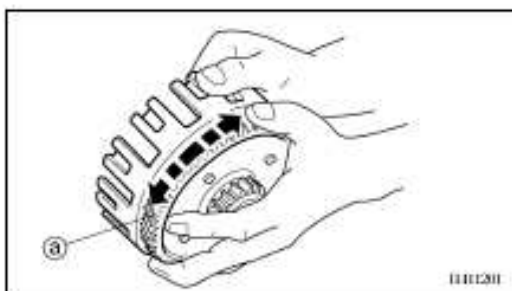

Primary driven gear

1. Check:
 - Circumferential play
Free play exists → Replace.
 - Gear teeth ③
Wear/damage → Replace.

TECHNICAL INFORMATION

CLUTCH AND PRIMARY DRIVEN GEAR

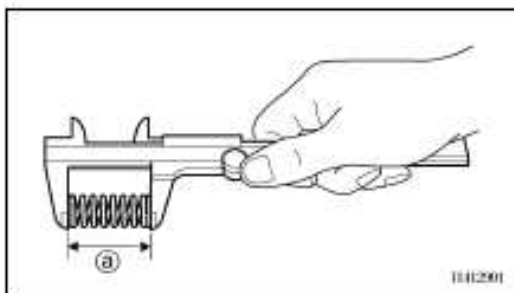

Clutch spring

1. Measure:
 - Clutch spring free length ③
 - Out of specification → Replace springs as a set.

	<p>Clutch spring free length: 33 mm (1.30 in) <Limit>: 31 mm (1.22 in)</p>
--	---



Friction plate

1. Measure:
 - Friction plate thickness
 - Out of specification → Replace friction plate as a set.
 - Measure at all four points.

	<p>Friction plate thickness: 2.92 ~ 3.08 mm (0.115 ~ 0.121 in) <Limit>: 2.8 mm (0.110 in)</p>
--	---

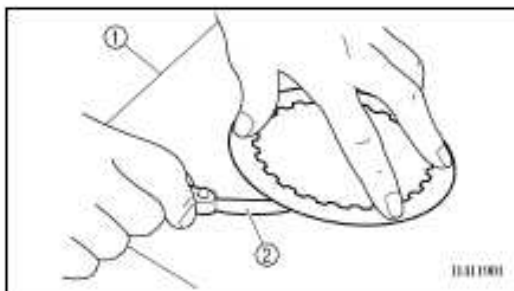

Clutch plate

1. Measure:
 - Clutch plate warpage
 - Out of specification → Replace clutch plate as a set.
 - Use a surface plate ① and thickness gauge ②.

	<p>Warp limit: 0.2 mm (0.008 in)</p>
--	--

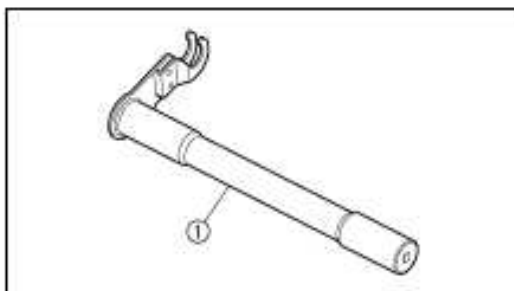

Push lever

1. Inspect:
 - Push lever ①
 - Wear/damage → Replace.

TECHNICAL INFORMATION

CLUTCH AND PRIMARY DRIVEN GEAR

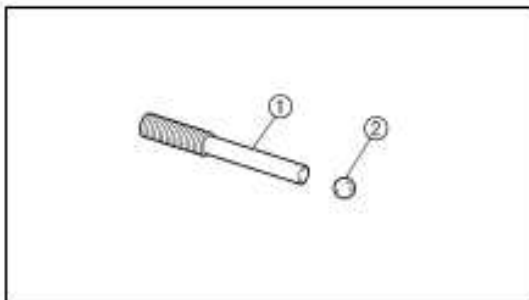

Push rod

1. Inspect:
 - Push rod 1 ①
 - Ball ②
 Wear/damage/bend → Replace.

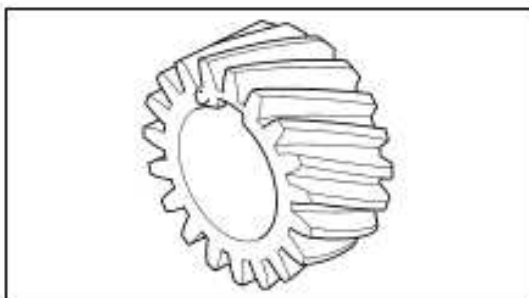

Primary drive gear

1. Inspect:
 - Primary drive gear
 Wear/damage → Replace.

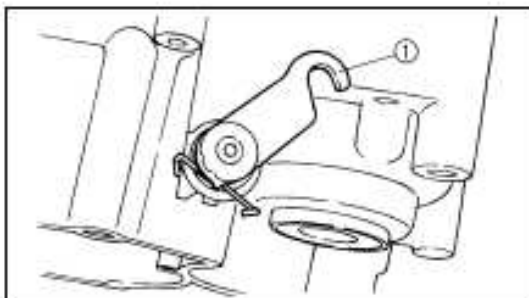

ASSEMBLY AND INSTALLATION

Push lever

1. Install:
 - Push lever ①

NOTE:

- Apply the lithium soap base grease on the oil seal lip.
- Apply the engine oil on the push lever.

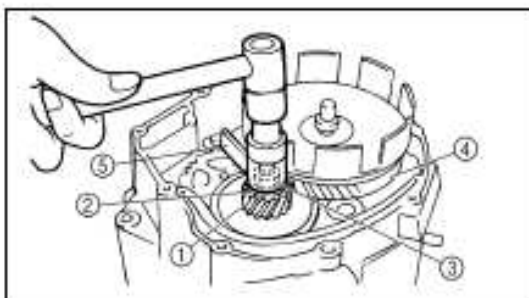

Primary drive gear

1. Install:
 - Straight key
 - Primary drive gear ①
 - Washer ②
 - Nut (primary drive gear) ③
 - 70 Nm (7.0 m · kg, 50 ft · lb)**
 - Primary driven gear ④

NOTE:

- Install the primary drive gear with the stamp ⑤ facing out.
- Place a folded rag or aluminum plate ⑤ between the teeth of the primary drive gear and primary driven gear.

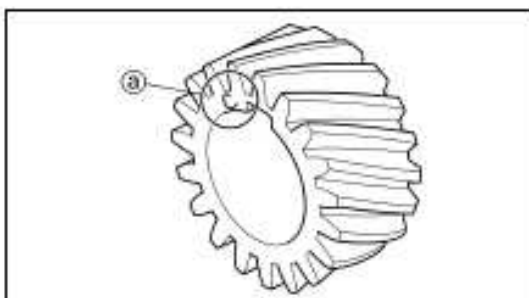

TECHNICAL INFORMATION

CLUTCH AND PRIMARY DRIVEN GEAR

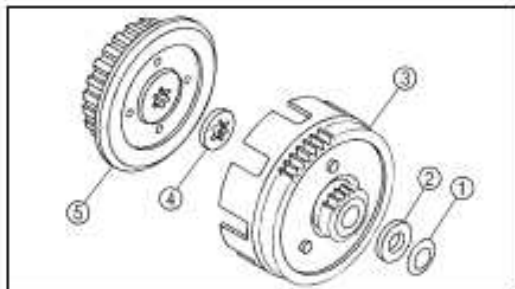

Clutch

1. Install:
 - Conical spring washer ①
 - Thrust plate ②
 - Primary driven gear ③
 - Thrust plate ④
 - Clutch boss ⑤

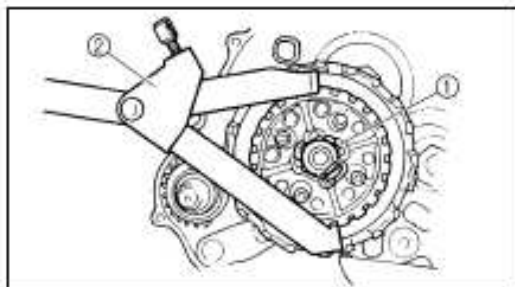

2. Install:
 - Lock washer
 - Nut (clutch boss) ①

60 Nm (6.0 m - kg, 43 ft - lb)

NOTE: Use the clutch holding tool ② to hold the clutch boss.

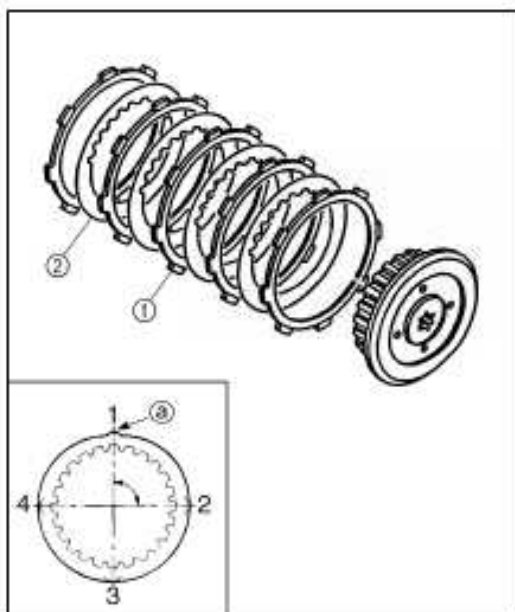
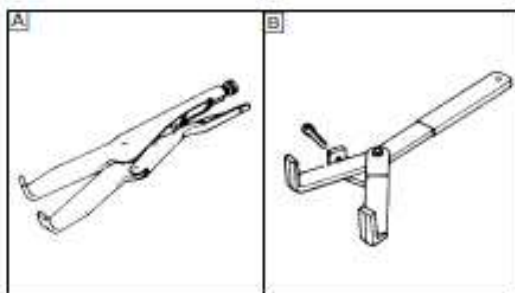

4. Install:
 - Friction plate ①
 - Clutch plate ②

NOTE:

- Install the clutch plates and friction plates alternately on the clutch boss, starting with a friction plate and ending with a friction plate.
- Apply the engine oil on the friction plates and clutch plates.
- Be sure to install a clutch plate with projection ③ offset approximately 90° from previous plates projection. Continue this procedure in a clockwise direction until all clutch plates are installed.

TECHNICAL INFORMATION

CLUTCH AND PRIMARY DRIVEN GEAR

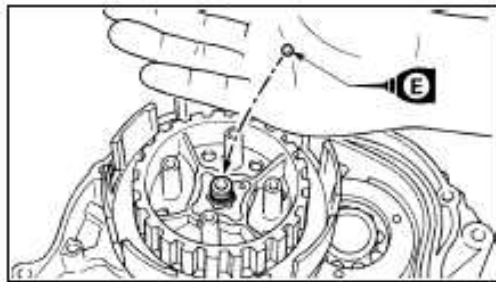

5. Install:
- Ball

NOTE: _____
Apply the engine oil on the ball.

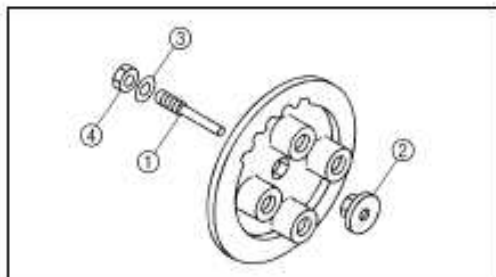

6. Install:
- Push rod 1 (1)
 - Push plate (2)
 - Washer (3)
 - Nut (push rod 1) (4)

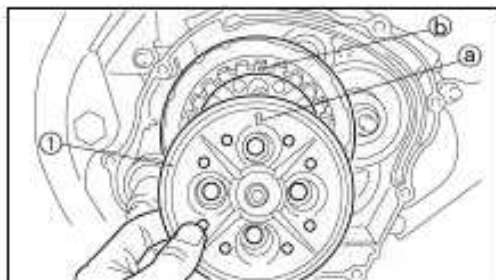

7. Install:
- Pressure plate (1)
 - Clutch spring (2)
 - Bolt (clutch spring) (3)

6 Nm (0.6 m - kg, 4.3 ft - lb)

NOTE: _____
• Align the arrow mark (a) on the pressure plate with the punched mark (b) on the clutch boss.
• Tighten the bolts in stage, using a crisscross pattern.

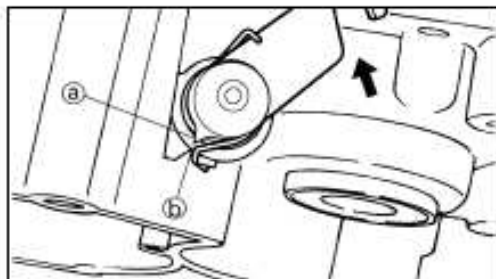
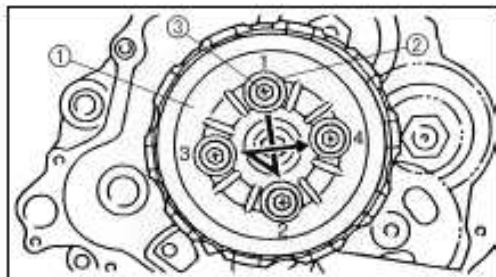

8. Check:
- Push lever position
Push the push lever assembly in the arrow direction and make sure that the mach mark are aligned → adjust.

(a) Match mark on the push lever assembly
(b) Match mark on the crankcase

TECHNICAL INFORMATION

CLUTCH AND PRIMARY DRIVEN GEAR

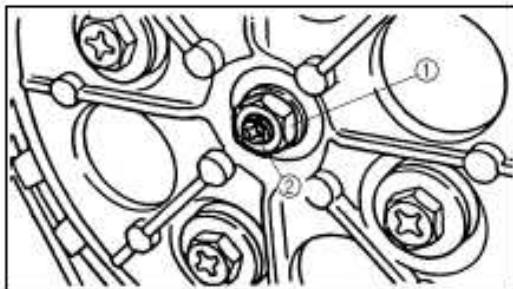

9. Adjust:
- Push lever position

- Adjustment steps:**
- Loosen the locknut ①.
 - Turn the push rod 1 ② clockwise or counterclockwise to match alignment marks.
 - Hold the push rod 1 to prevent it from moving and tighten the locknut to specification.
 - Tighten the locknut ①.



Locknut:
8 Nm (0.8 m • kg, 5.8 ft • lb)

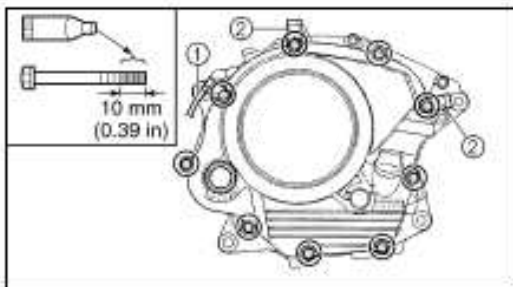

10. Install:
- Dowel pins
 - Gasket (right crankcase cover)
 - Right crankcase cover

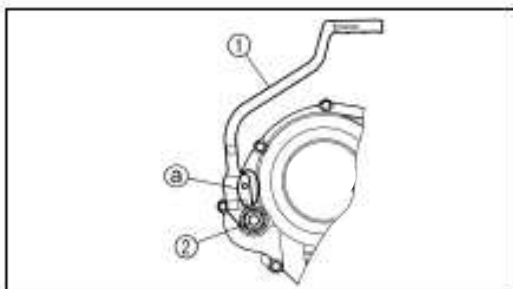

11. Install:
- Kickstarter crank ①
 - Nut (kickstarter crank) ②

50 Nm (5.0 m • kg, 36 ft • lb)

NOTE:
Install the kickstarter crank so that there is 5 - 10 mm (0.2 - 0.4 in) ③ between the kickstarter crank and the right crankcase cover.

OIL PUMP

OIL PUMP

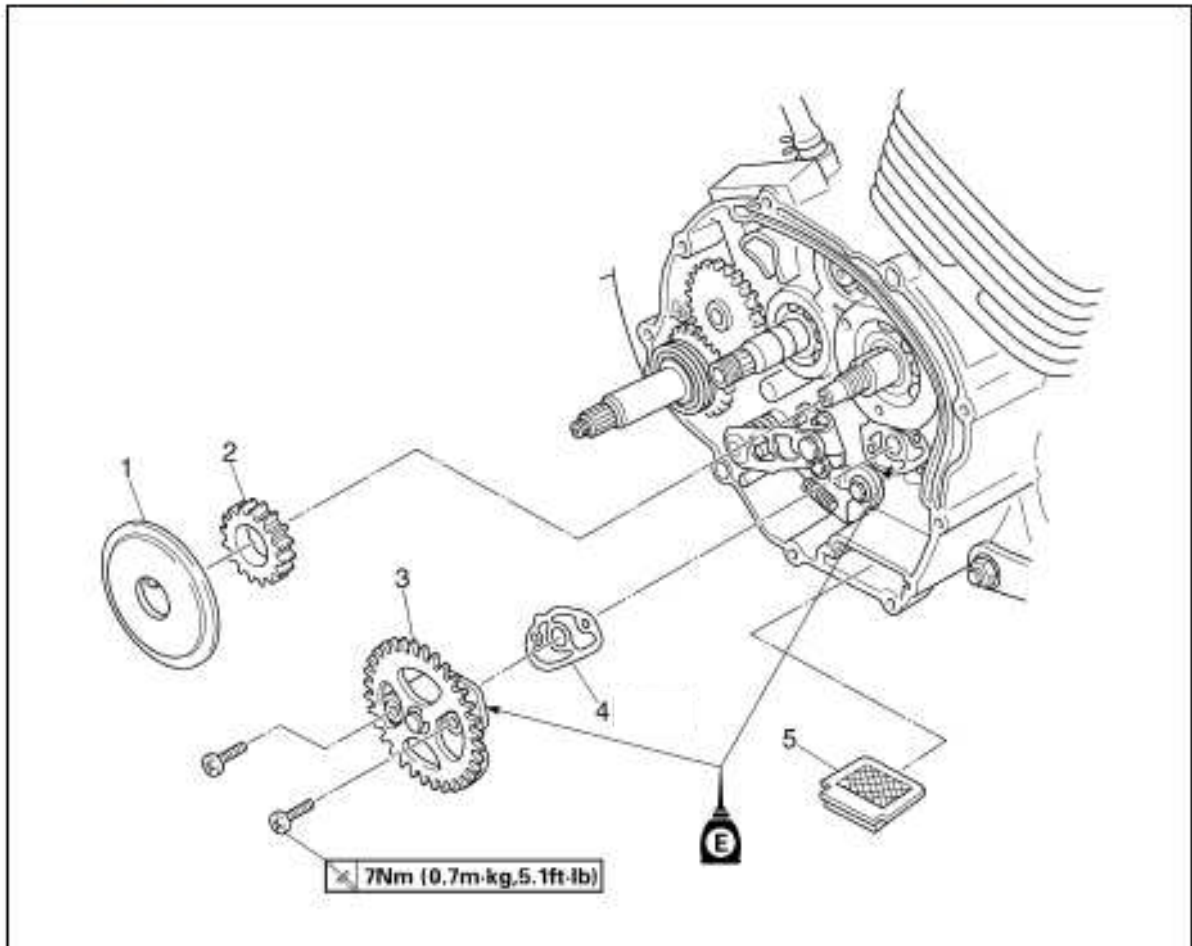

OIL PUMP

OIL PUMP DISASSEMBLY

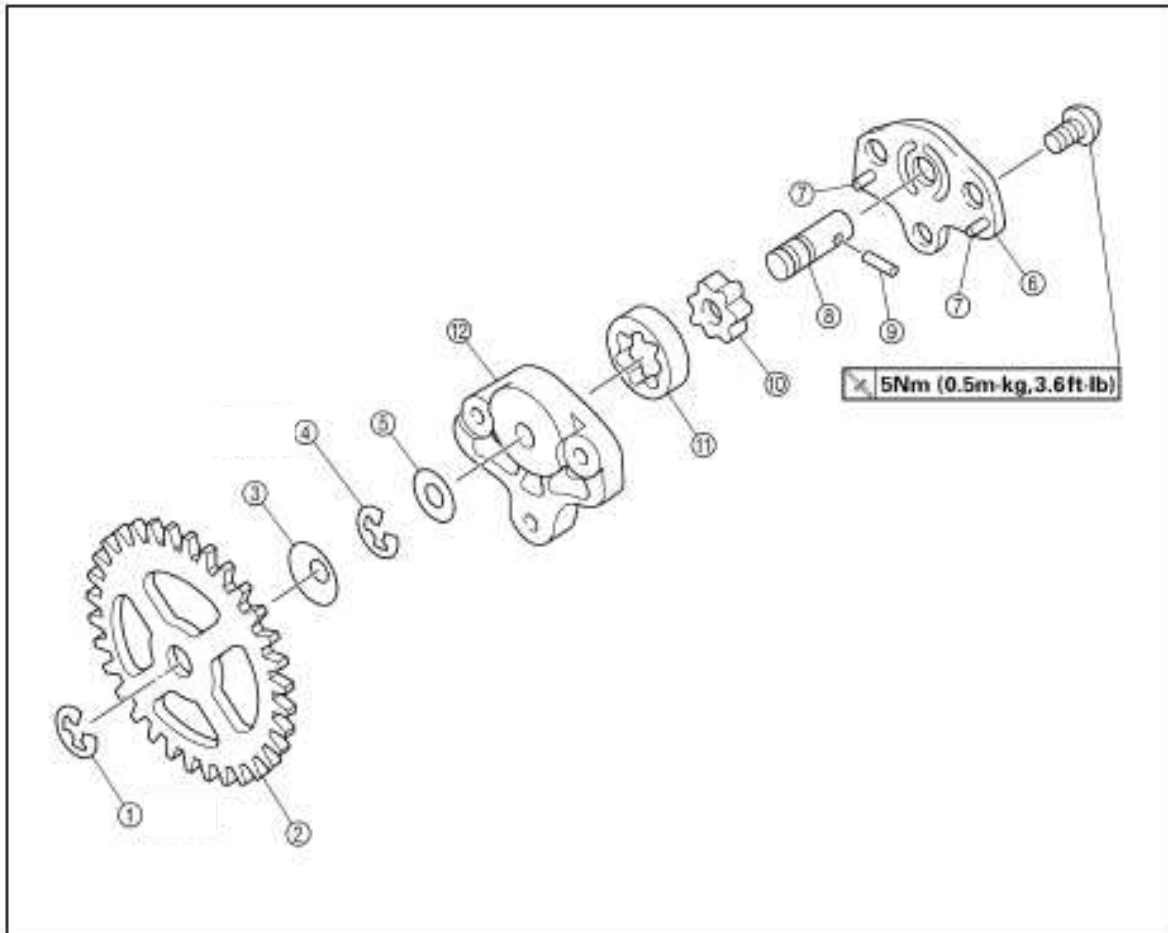

OIL PUMP

INSPECTION

Oil pump

1. Inspect:
 - Oil pump drive gear
 - Oil pump driven gear
 - Oil pump housing
 - Oil pump cover
 Cracks/wear/damage → Replace.

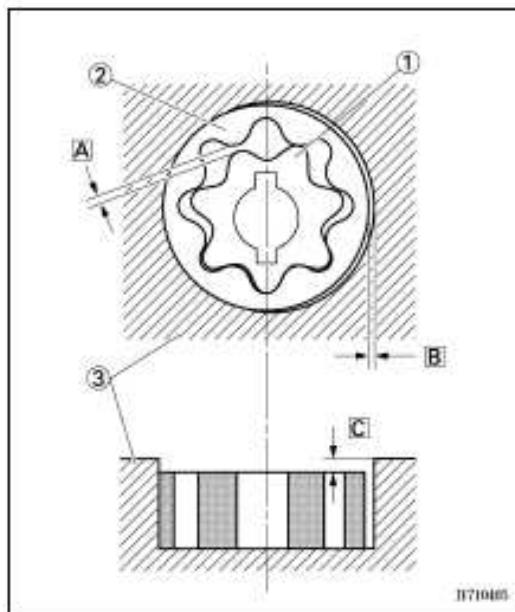

2. Measure:
 - Tip clearance **A**
(between the inner rotor ① and the outer rotor ②)
 - Side clearance **B**
(between the outer rotor ② and the oil pump housing ③)
Out of specification → Replace the oil pump assembly.
 - Housing and rotor clearance **C**
(between the pump housing ③ and the rotors ① ②)
Out of specification → Replace the oil pump assembly.

	Tip clearance A:
	0.15 mm (0.0059 in) <Limit>: 0.20 mm (0.0079 in)
	Side clearance B:
	0.06 - 0.10 mm (0.0024 - 0.0039 in) <Limit>: 0.15 mm (0.0059 in)
	Housing and rotor clearance C:
	0.06 - 0.10 mm (0.0024 - 0.0039 in) <Limit>: 0.15 mm (0.0059 in)

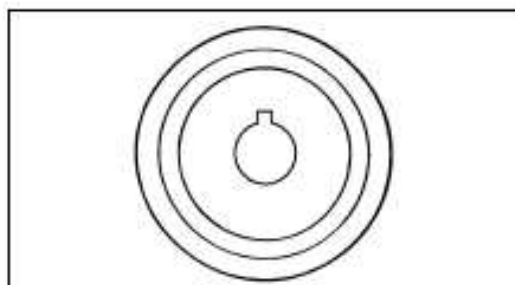

Rotary filter

1. Inspect:
 - Rotary filter
 Cracks/damage → Replace.

OIL PUMP

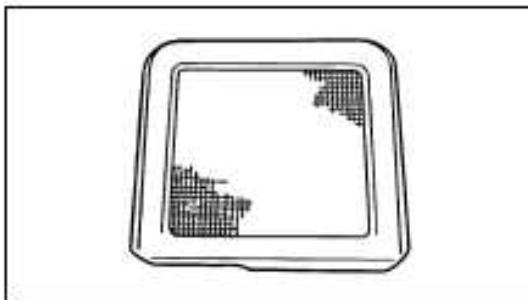

Oil strainer

1. Inspect:
 - Oil strainer
 - Cracks/damage → Replace.
 - Contamination → Clean the flushing oil.

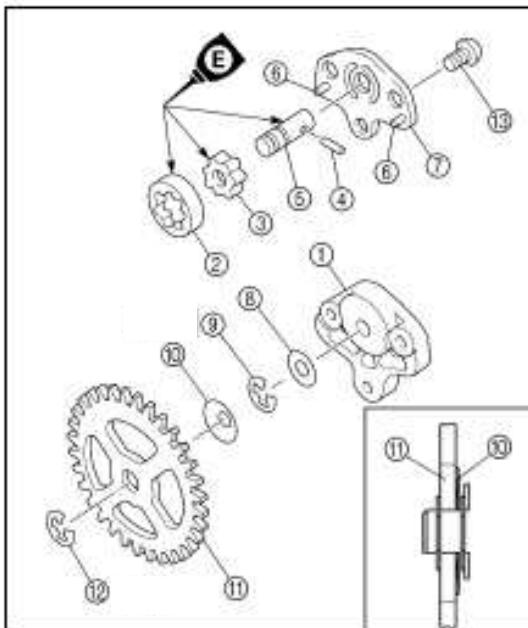

ASSEMBLY AND INSTALLATION

Oil pump

1. Install:
 - Oil pump housing ①
 - Outer rotor ②
 - Inner rotor ③
 - Pin ④
 - Oil pump shaft ⑤
 - Pin ⑥
 - Oil pump cover ⑦
 - Washer ⑧
 - Circlip ⑨
 - Conical spring washer ⑩
 - Oil pump driven gear ⑪
 - Circlip ⑫
 - Screws ⑬

5 Nm (0.5 m - kg, 3.6 ft - lb)

NOTE:

- Apply engine oil onto the outer rotor, inner rotor and oil pump shaft.
- Install the conical spring washer in the direction as shown.

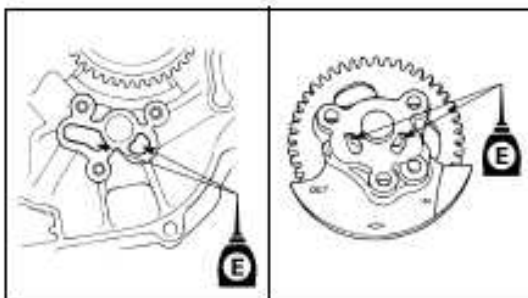

2. Install:
 - Oil strainer
 - Gasket
 - Oil pump assembly
 - Screws (oil pump assembly)

7 Nm (0.7 m - kg, 5.1 ft - lb)

NOTE:

Apply engine oil onto the crankcase oil passage and oil pump assembly.

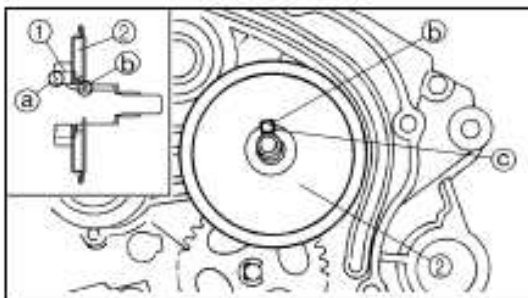

3. Install:
 - Oil pump drive gear ①
 - Rotary filter ②

NOTE:

- Install the oil pump drive gear with its groove ② facing the engine.
- Install the rotary filter with the dog ② facing out.
- Align the rotary filter dog ② with groove ③ of the crankshaft.

TECHNICAL INFORMATION

KICK AXLE AND SHIFT SHAFT

KICK AXLE AND SHIFT SHAFT
KICK AXLE AND SHIFT SHAFT

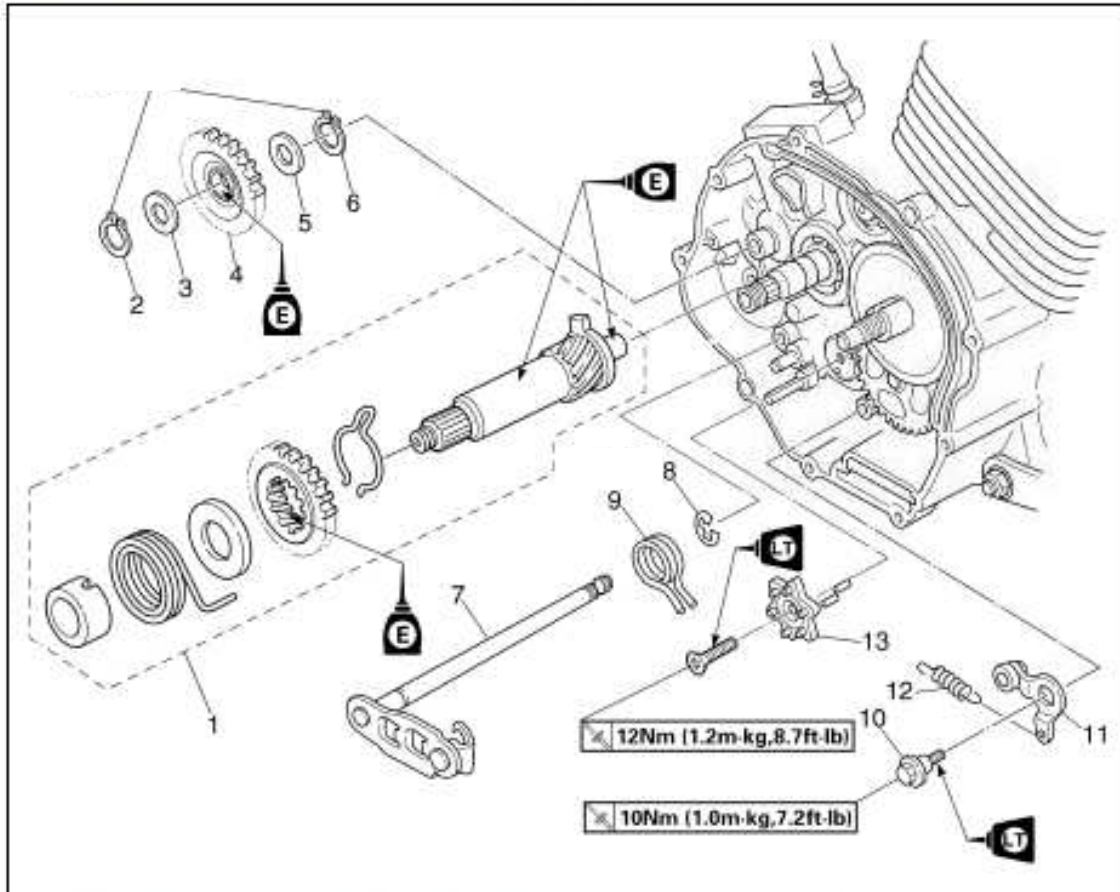

TECHNICAL INFORMATION

KICK AXLE AND SHIFT SHAFT



REMOVAL POINTS

Kick axle

1. Remove:
 - Kick axle assembly ①

NOTE:

Unhook the torsion spring ② from the hole in the crankcase.

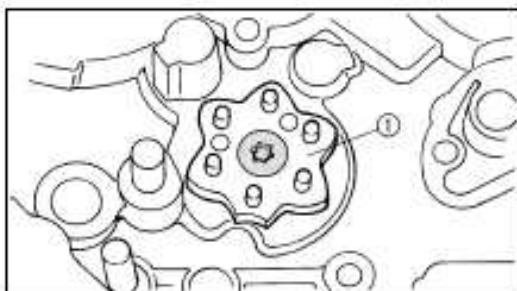

Segment

1. Remove:
 - Screw (segment)
 - Segment ①

NOTE:

Loosen the screw using the T30 bit.

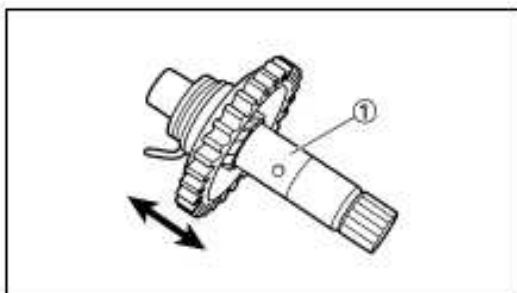

INSPECTION

Kick axle and kickstarter segment gear

1. Check:
 - Kickstarter segment gear smooth movement
Unsmooth movement → Replace.
2. Inspect:
 - Kick axle ①
Wear/damage → Replace.

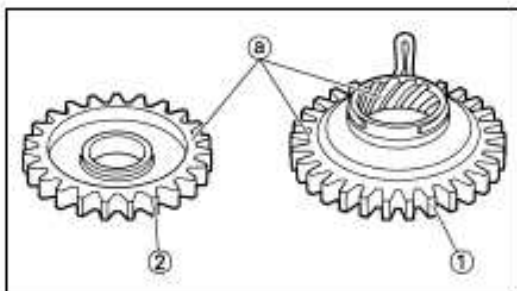

Kickstarter segment gear and kick idle gear

1. Inspect:
 - Kickstarter segment gear ①
 - Kick idle gear ②
 - Gear teeth ③
Wear/damage → Replace.

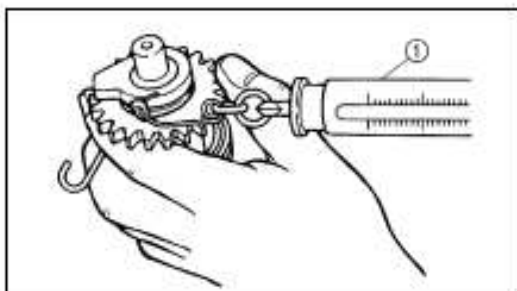

Kick axle clip

1. Measure:
 - Kick axle clip friction force (torsion spring)
Out of specification → Replace.
Use a spring gauge ①.

	<p>Kick axle clip friction force: 0.65 - 1.35 kg (1.4 - 3.0 lb)</p>
---	--

KICK AXLE AND SHIFT SHAFT

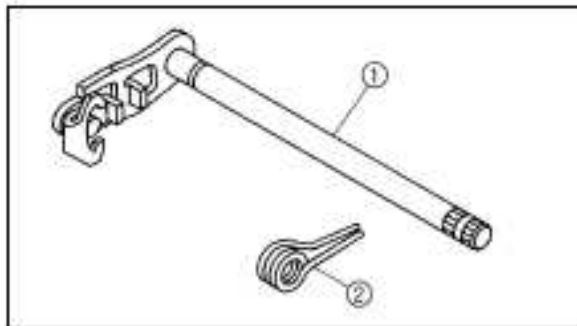

EC484400

Shift shaft

1. Inspect:
 - Shift shaft ①
Bend/damage → Replace.
 - Spring ②
Broken → Replace.

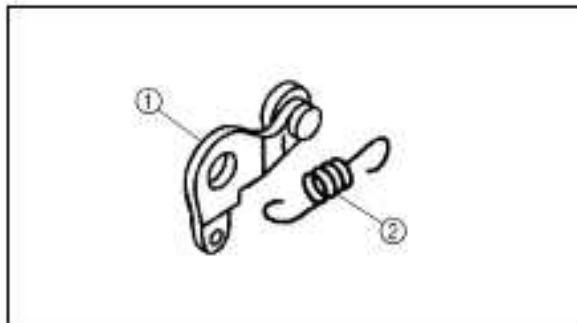

EC484500

Stopper lever

1. Inspect:
 - Stopper lever ①
Wear/damage → Replace.
 - Torsion spring ②
Broken → Replace.

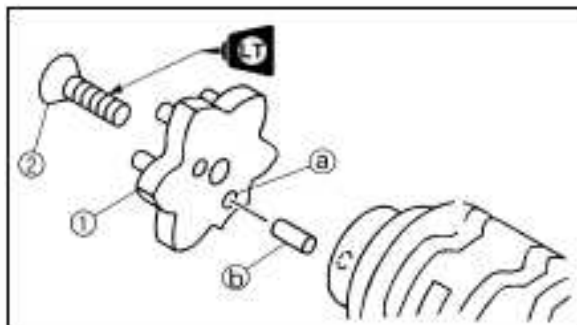

EC4C5000

ASSEMBLY AND INSTALLATION

Segment

1. Install:
 - Segment ①
 - Screw (segment) ②

12 Nm (1.2 m · kg, 8.7 ft · lb)

NOTE:

- Align the notch (a) on the segment with the pin (b) on the shift cam.
- Tighten the screw using the T30 bit.

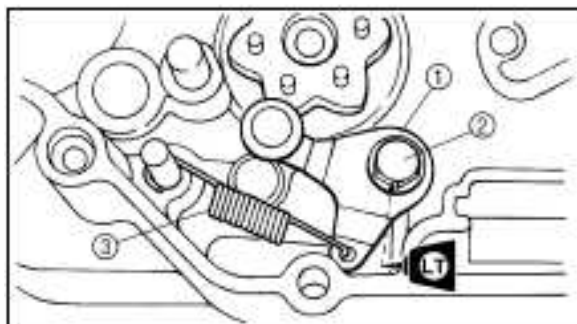

Stopper lever

1. Install:
 - Stopper lever ①
 - Bolt (stopper lever) ②

10 Nm (1.0 m · kg, 7.2 ft · lb)

- Torsion spring ③

NOTE:

- Align the stopper lever roller with the slot on segment.

TECHNICAL INFORMATION

KICK AXLE AND SHIFT SHAFT

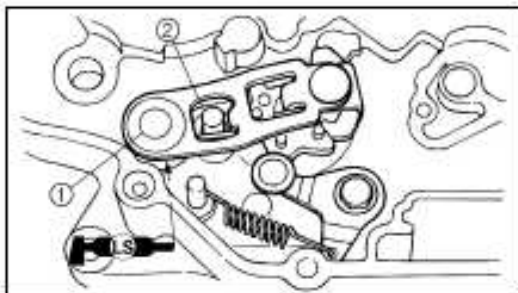

Shift shaft

1. Install:
 - Shift shaft (1)

NOTE:

- Apply the lithium soap base grease on the oil seal lip of the left crankcase side.
- Hook the spring ends onto the stopper (2).

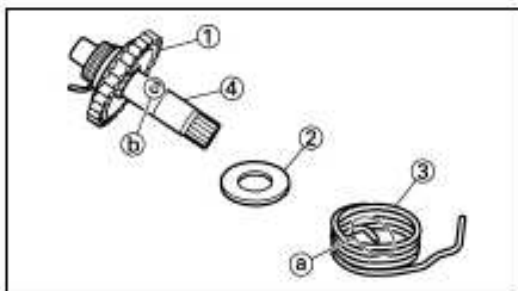

Kick axle assembly

1. Install:
 - Kickstarter segment gear (1)
 - Plain washer (2)
 - Torsion spring (3)
 On kick axle (4).

NOTE:

Make sure the stopper (a) of the torsion spring fits into the hole (b) on the kick axle.

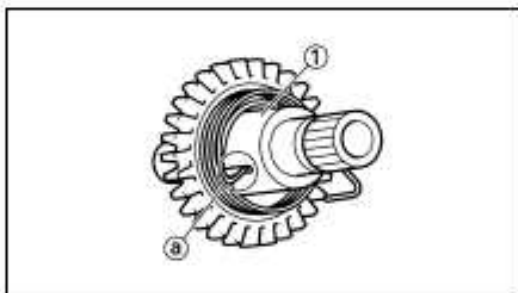

2. Install:
 - Spring guide (1)

NOTE:

Slide the spring guide into the kick axle, make sure the groove (a) in the spring guide fits on the stopper of the torsion spring.

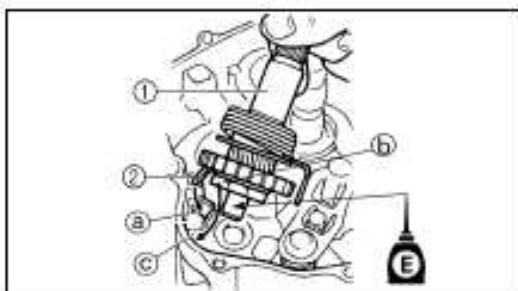

3. Install:
 - Kick axle assembly (1)

NOTE:

- Apply the engine oil on the kick axle.
- Slide the kick axle assembly into the crankcase, make sure the clip (2) and kick axle stopper (b) fit into their home positions (a), (c).

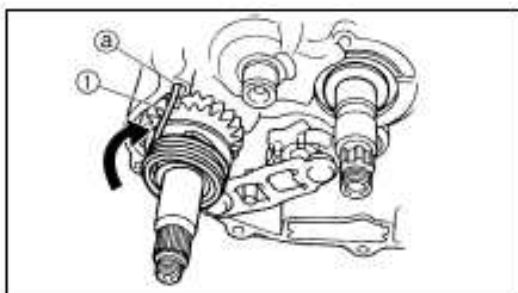

4. Hook:
 - Torsion spring (1)

NOTE:

Turn the torsion spring clockwise and hook into the proper hole (a) in the crankcase.

KICK AXLE AND SHIFT SHAFT

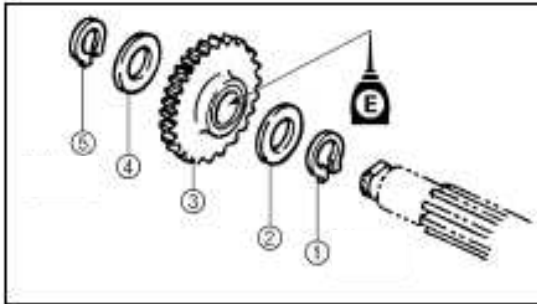

Kick idle gear

1. Install:
 - Circlip ①
 - Washer ②
 - Kick idle gear ③
 - Washer ④
 - Circlip ⑤

NOTE:

- Apply the engine oil on the kick idle gear inner circumference.
- Install the kick idle gear with its depressed side toward you.

TECHNICAL INFORMATION

CDI MAGNETO

CDI MAGNETO

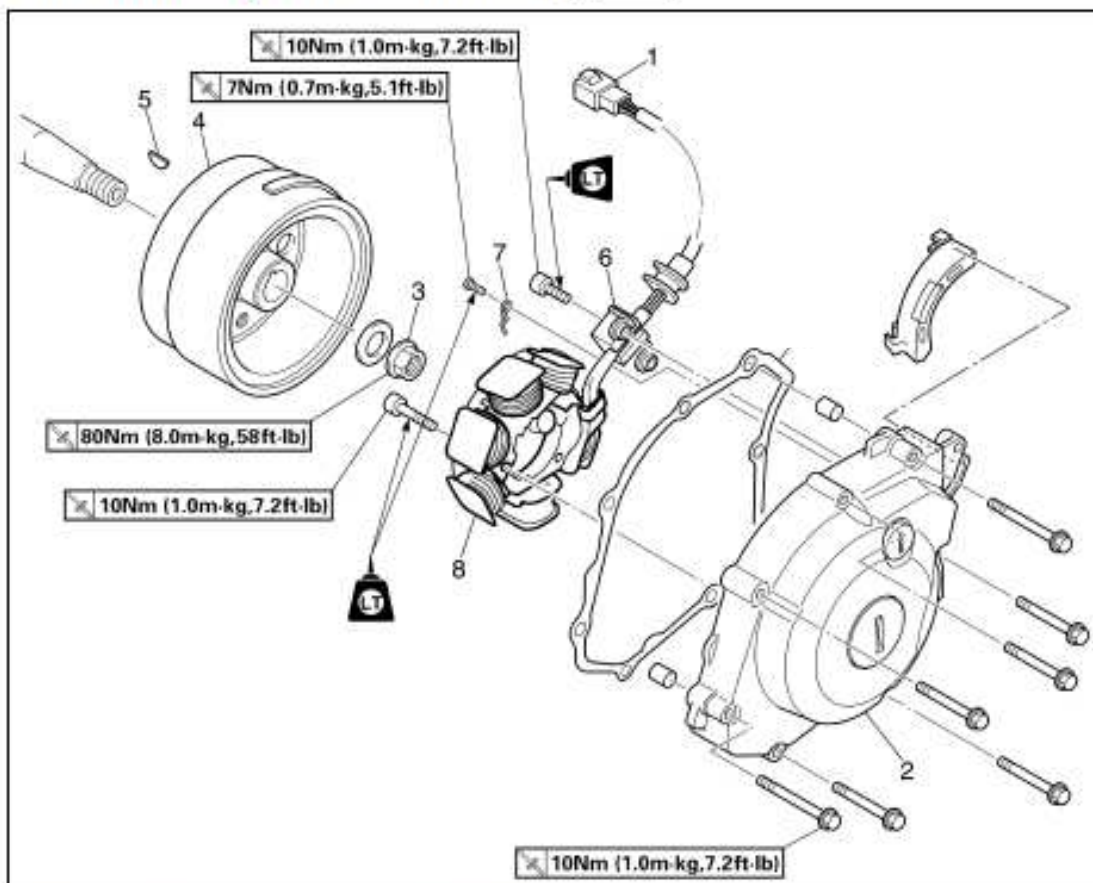

TECHNICAL INFORMATION

CDI MAGNETO

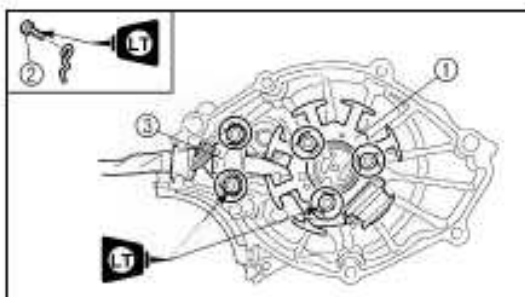
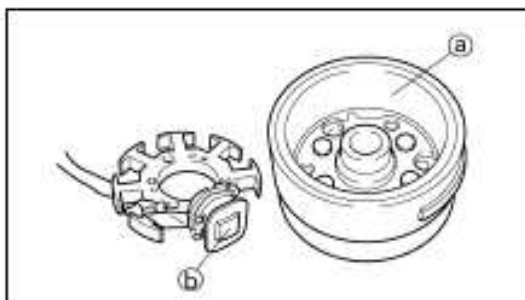
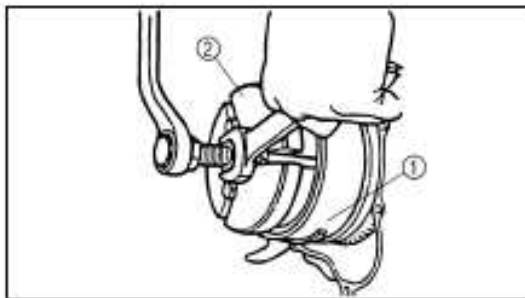
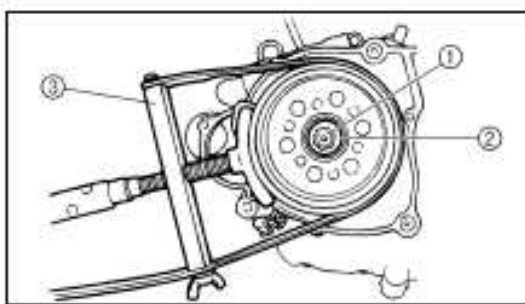

REMOVAL POINTS

Rotor

1. Remove:
 - Nut (rotor) ①
 - Plain washer ②
 - Use the sheave holder ③.

2. Remove:
 - Rotor ①
 - Use the flywheel puller ②.

INSPECTION

CDI magneto

1. Inspect:
 - Rotor inner surface ③
 - Stator outer surface ④

Damage → Inspect the crankshaft runout and crankshaft bearing.
If necessary, replace CDI magneto and/or stator.

Woodruff key

1. Inspect:
 - Woodruff key ①

Damage → Replace.

ASSEMBLY AND INSTALLATION

CDI magneto

1. Install:
 - Stator ①
 - Bolt (stator)
 - 10 Nm (1.0 m · kg, 7.2 ft · lb)
 - Lead guide
 - Screw (lead guide) ②
 - 7 Nm (0.7 m · kg, 5.1 ft · lb)
 - Pickup coil ③
 - Bolt (pickup coil)
 - 10 Nm (1.0 m · kg, 7.2 ft · lb)

TECHNICAL INFORMATION

CDI MAGNETO

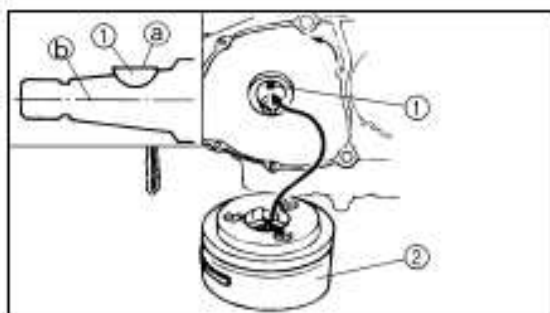

2. Install:
 - Woodruff key ①
 - Rotor ②

NOTE:

- Clean the tapered portions of the crankshaft and rotor.
- When installing the woodruff key, make sure that its flat surface ③ is in parallel with the crankshaft center line ④.
- When installing the rotor, align the keyway of the rotor with the woodruff key.

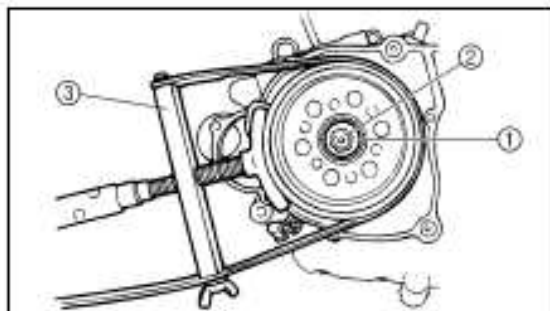

3. Install:
 - Plain washer ①
 - Nut (rotor) ②

80 Nm (8.0 m · kg, 58 ft · lb)

Use the sheave holder ③.

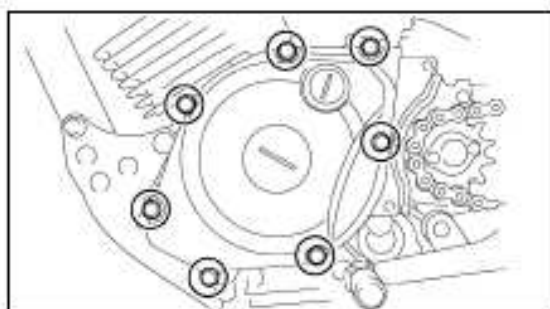

4. Install:
 - Dowel pin
 - Gasket **New**
 - Left crankcase cover
 - Bolt (left crankcase cover)

10 Nm (1.0 m · kg, 7.2 ft · lb)

NOTE:

Tighten the screws in stage, using a crisscross pattern.

5. Connect:
 - CDI magneto lead

Refer to "CABLE ROUTING DIAGRAM" section in the CHAPTER 2.

CDI MAGNETO AND STARTER CLUTCH

CDI MAGNETO AND STARTER CLUTCH

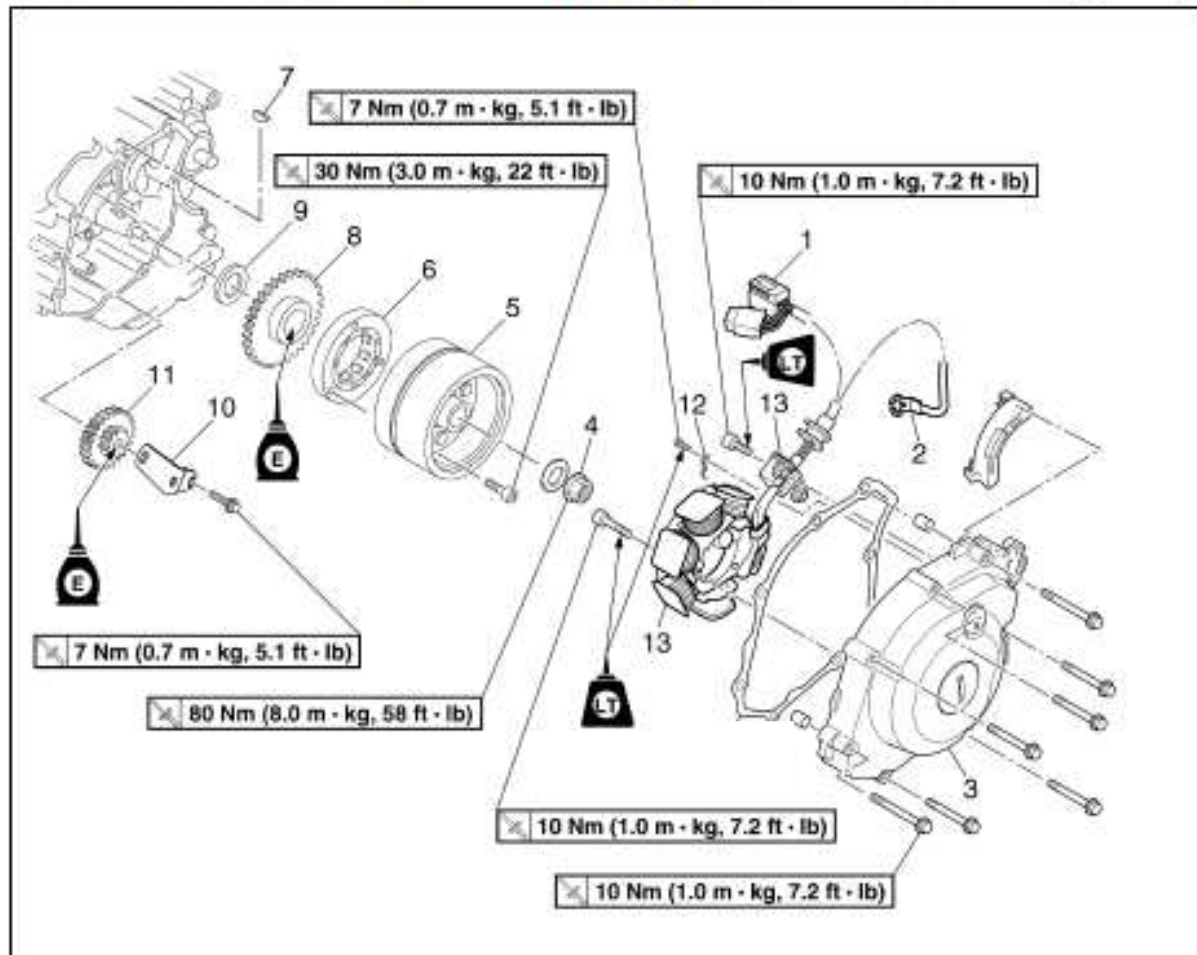

TECHNICAL INFORMATION

CDI MAGNETO AND STARTER CLUTCH

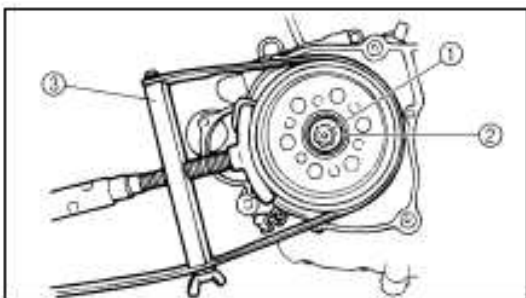

REMOVAL POINTS

Rotor

1. Remove:
 - Nut (rotor) ①
 - Plain washer ②
 - Use the sheave holder ③.

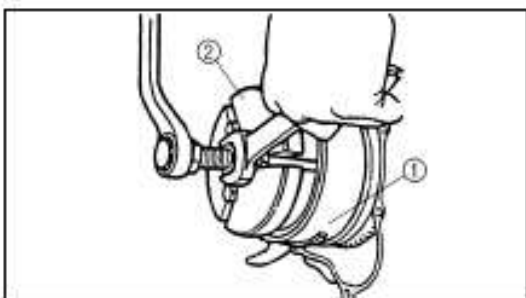

2. Remove:
 - Rotor ①
 - Use the flywheel puller ②.

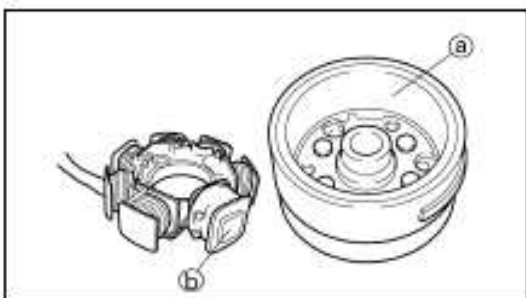

INSPECTION

CDI magneto

1. Inspect:
 - Rotor inner surface ②
 - Stator outer surface ③

Damage → Inspect the crankshaft runout and crankshaft bearing.
If necessary, replace CDI magneto and/or stator.

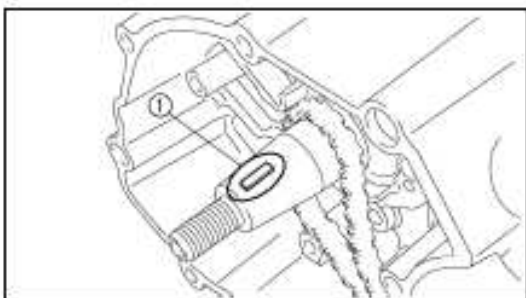

Woodruff key

1. Inspect:
 - Woodruff key ①

Damage → Replace.

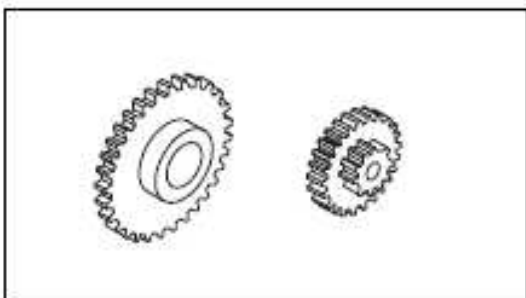

Starter clutch

1. Check:
 - Starter clutch

Damage/wear → Replace.
2. Check:
 - Idle gear
 - Starter clutch gear

Pitting/burrs/chips/roughness/wear → Replace the defective parts.

TECHNICAL INFORMATION

CDI MAGNETO AND STARTER CLUTCH

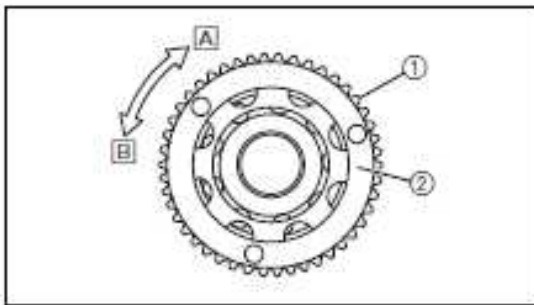

3. Check:
- Starter clutch operation

- Install the starter clutch drive gear (1) onto the starter clutch (2) and hold the starter clutch.
- When turning the starter clutch drive gear counterclockwise [B], the starter clutch and the starter clutch drive gear should engage. If the starter clutch drive gear and starter clutch do not engage, the starter clutch is faulty and must be replaced.
- When turning the starter clutch drive gear clockwise [A], it should turn freely. If the starter clutch drive gear does not turn freely, the starter clutch is faulty and must be replaced.

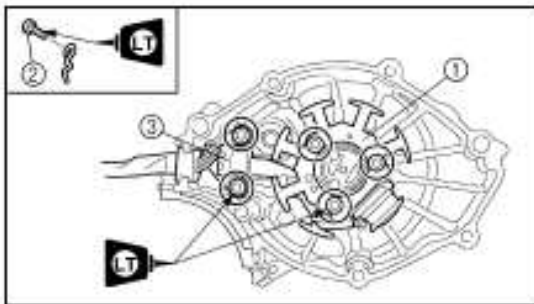

ASSEMBLY AND INSTALLATION
CDI magneto

1. Install:
- Stator (1)
 - Bolt (stator)
 - 10 Nm (1.0 m · kg, 7.2 ft · lb)
 - Lead guide
 - Screw (lead guide) (2)
 - 7 Nm (0.7 m · kg, 5.1 ft · lb)
 - Pickup coil (3)
 - Bolt (pickup coil)
 - 10 Nm (1.0 m · kg, 7.2 ft · lb)

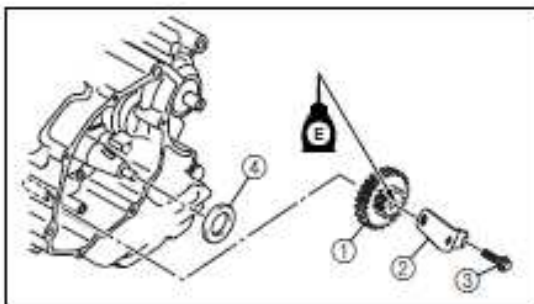

2. Install:
- Stator idle gear (1)
 - Plate (2)
 - Bolt (3) 7 Nm (0.7 m · kg, 5.1 ft · lb)
 - Washer (4)

NOTE: _____
Apply the engine oil on the starter idle gear inner circumference.

TECHNICAL INFORMATION

CDI MAGNETO AND STARTER CLUTCH

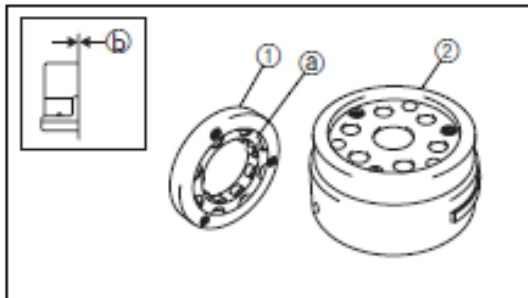

3. Install the starter clutch (1) on the rotor (2).

NOTE:

- Install the starter clutch with its plate portion (a) facing the rotor.
- Insert the plate portion of the starter clutch so that it is flush with the surface of contact (b) with the rotor.

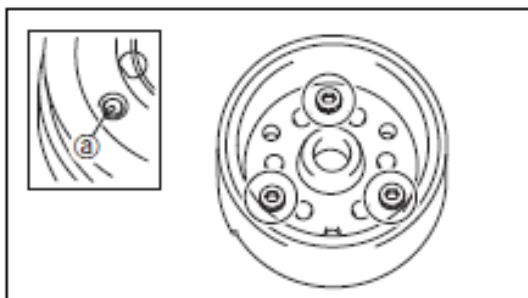

4. Tighten:

- Bolt (starter clutch)

30 Nm (3.0 m · kg, 22 ft · lb)

NOTE:

Caulk (a) the end of the starter clutch holding bolt near its outer diameter to serve as a stopper.

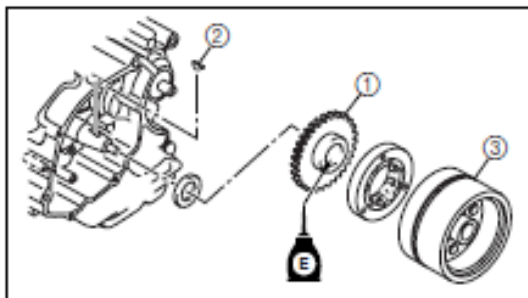

5. Install:

- Starter wheel gear (1)
- Woodruff key (2)
- Rotor (3)

NOTE:

- Clean the tapered portion of the crankshaft and the magneto hub.
- When installing the magneto rotor, make sure the woodruff key is properly seated in the key way of the crankshaft.
- Apply the engine oil on the starter wheel gear inner circumference.

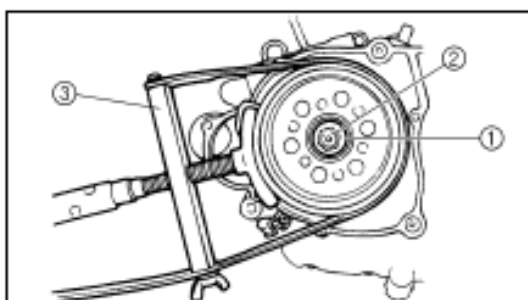

6. Install:

- Plain washer (1)
- Nut (magneto) (2)

80 Nm (8.0 m · kg, 58 ft · lb)

NOTE:

Tighten the nut (magneto) while holding the magneto with a sheave holder (3).

CDI MAGNETO AND STARTER CLUTCH

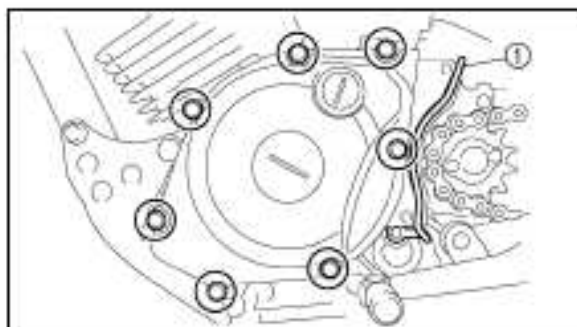

7. Install:
 - Crankcase cover (left)
8. Connect:
 - Neutral switch lead ①

NOTE: Pass the neutral switch lead into the crankcase cover groove as shown.

9. Connect:
 - CDI magneto lead

TECHNICAL INFORMATION

CRANKCASE, CRANKSHAFT AND BALANCER

CRANKCASE, CRANKSHAFT AND BALANCER

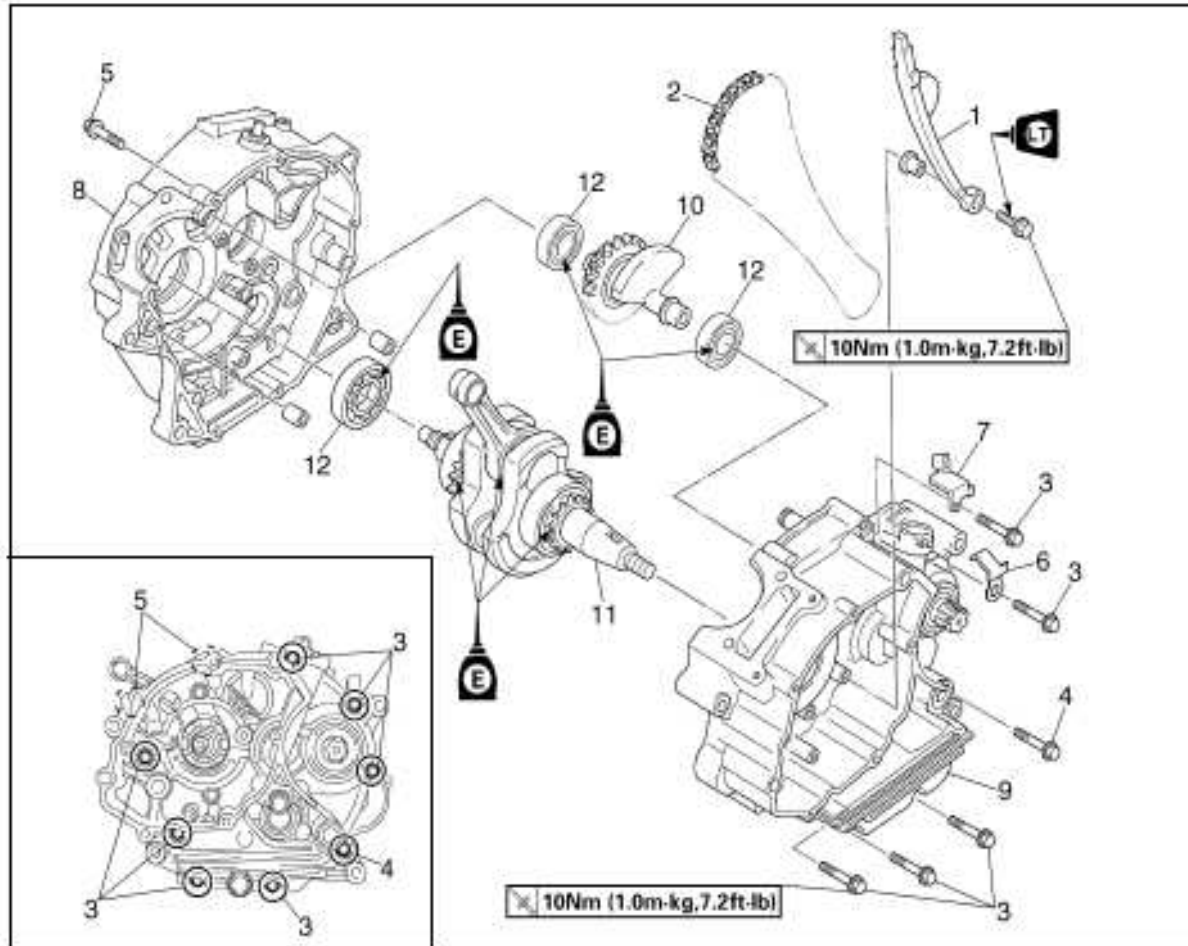

CRANKCASE, CRANKSHAFT AND BALANCER

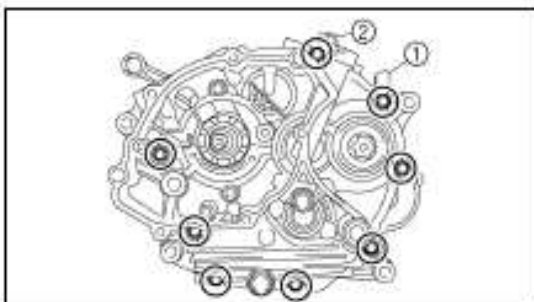

REMOVAL POINTS

Crankcase

1. Remove:
 - Bolt (crankcase)
 - Lead guide ①
 - Clutch cable holder ②

NOTE:

Loosen each bolt 1/4 of a turn at a time and after all the bolts are loosened, remove them.

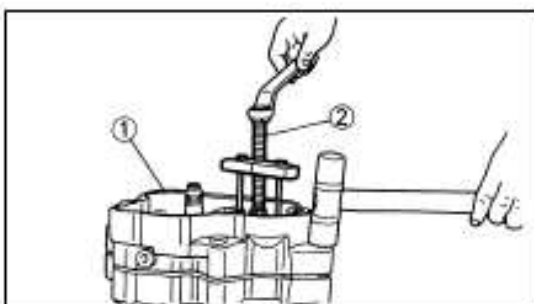
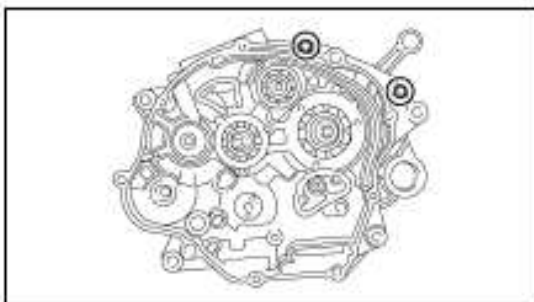

2. Remove:
 - Right crankcase ①
 - Use the crankcase separating tool ②.

NOTE:

- Fully tighten the tool holding bolts, but make sure the tool body is parallel with the case. If necessary, one screw may be backed out slightly to level tool body.
- As pressure is applied, alternately tap on the front engine mounting boss and transmission shafts.

CAUTION:

Use soft hammer to tap on the case half. Tap only on reinforced portions of case. Do not tap on gasket mating surface. Work slowly and carefully. Make sure the case halves separate evenly. If one end "hangs up", take pressure off the push screw, realign, and start over. If the cases do not separate, check for a remaining case screw or fitting. Do not force.

CRANKCASE, CRANKSHAFT AND BALANCER

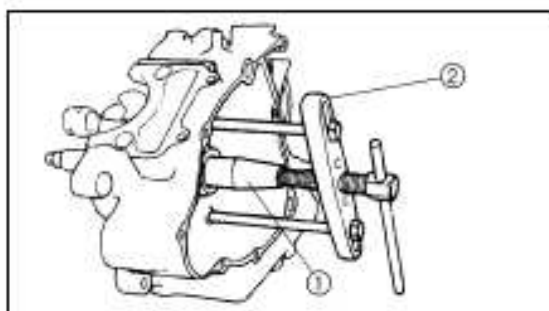

Crankshaft

1. Remove:
 - Crankshaft ①
 - Use the crankcase separating tool ②.

CAUTION:

Do not use a hammer to drive out the crankshaft.

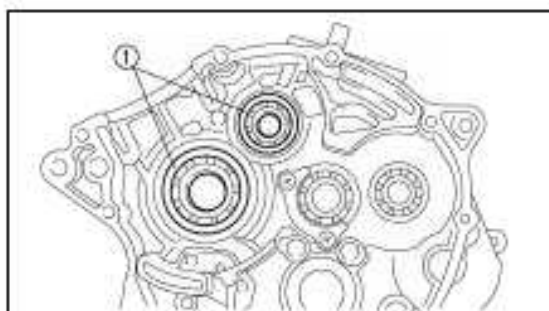

Bearing

1. Remove:
 - Bearing ①

NOTE:

- Remove the bearing from the crankcase by pressing its inner race as shown in.
- Do not use the removed bearing.

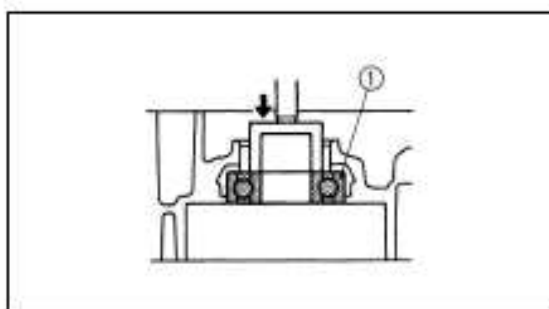

INSPECTION

Timing chain and timing chain guide

1. Inspect:
 - Timing chain
 - Cracks/stiff → Replace the timing chain and camshaft sprocket as a set.
2. Inspect:
 - Timing chain guide
 - Wear/damage → Replace.

CRANKCASE, CRANKSHAFT AND BALANCER

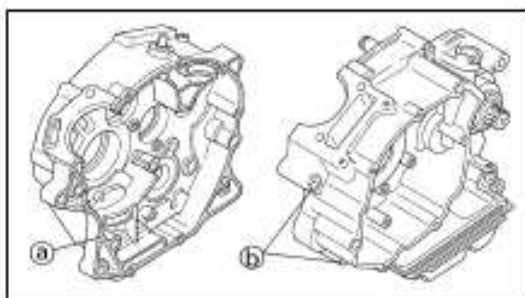

Crankcase

1. Inspect:
 - Contacting surface (a)
Scratches → Replace.
 - Engine mounting boss (b), crankcase
Cracks/damage → Replace.

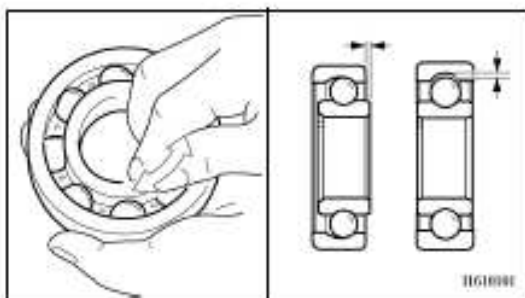

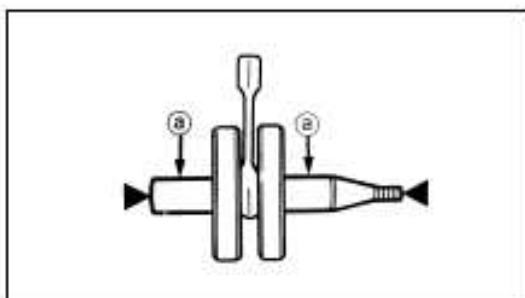

2. Inspect:
 - Bearing
Rotate inner race with a finger.
Rough spot/seizure → Replace.

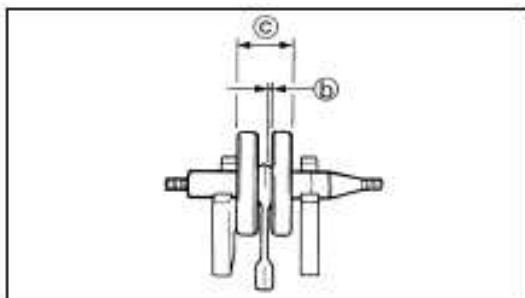

Crankshaft

1. Measure:
 - Runout limit (a)
 - Connecting rod big end side clearance (b)
 - Crank width (c)
Out of specification → Replace.
Use the dial gauge and a thickness gauge.



	Standard	<Limit>
Runout limit:	—	0.03 mm (0.0012 in)
Side clearance:	0.15 - 0.45 mm (0.0059 - 0.0177 in)	0.50 mm (0.02 in)
Crack width:	46.95 - 47.00 mm (1.848 - 1.850 in)	—

CRANKCASE, CRANKSHAFT AND BALANCER



Balancer

1. Inspect:
 - Balancer
 - Cracks/damage → Replace.

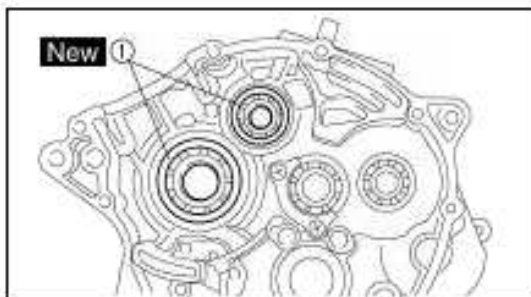

ASSEMBLY AND INSTALLATION

Bearing

1. Install:
 - Bearing ①
 - On crankcase (left and right).

NOTE: _____
Install the bearing by pressing its outer race parallel.

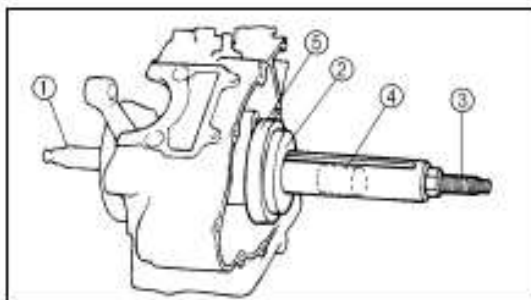

Crankshaft

1. Install:
 - Crankshaft ①
 - Use the crankshaft installing tool ②, ③, ④, ⑤.

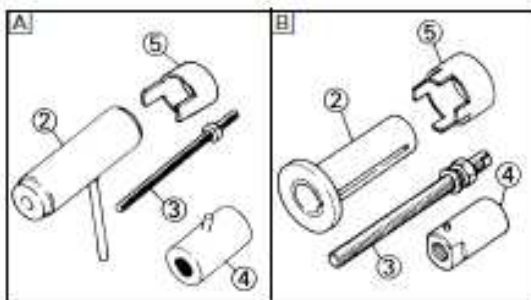

NOTE: _____

- Hold the connecting rod at top dead center with one hand while turning the nut of the installing tool with the other. Operate the installing tool until the crankshaft bottoms against the bearing.
- Before installing the crankshaft, clean the contacting surface of crankcase.

CAUTION: _____
Do not use a hammer to drive in the crankshaft.

CRANKCASE, CRANKSHAFT AND BALANCER

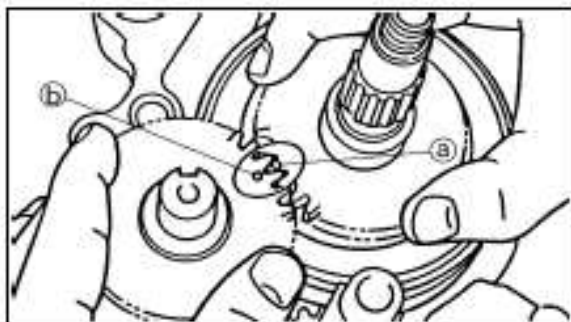

2. Install:
 - Balancer

NOTE: _____
Align the punched mark (a) on the balancer drive gear with the punched mark (b) on the balancer driven gear.

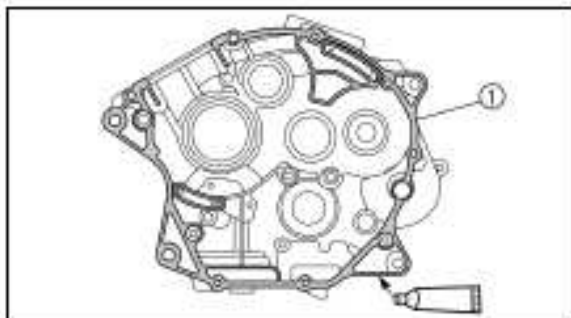

- Crankcase**
1. Apply:
 - Sealant
 On the right crankcase (1).

NOTE: _____
Clean the contacting surface of crankcase (left and right) before applying the sealant.

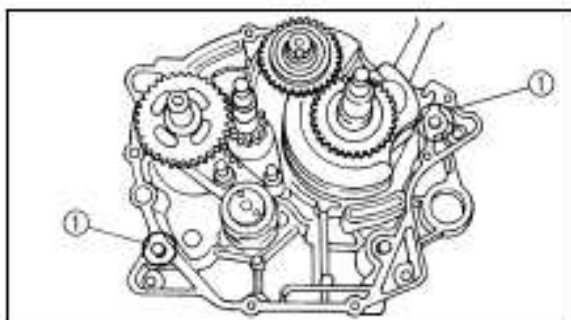

2. Install:
 - Dowel pin (1)
 - Right crankcase
 On left crankcase.

NOTE: _____
• Fit the right crankcase onto the left crankcase. Tap lightly on the case with soft hammer.
• When installing the crankcase, the connecting rod should be positioned at TDC (top dead center).

CRANKCASE, CRANKSHAFT AND BALANCER

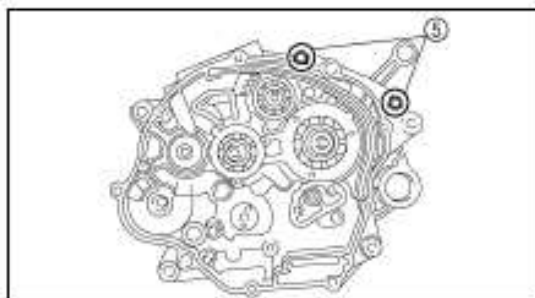
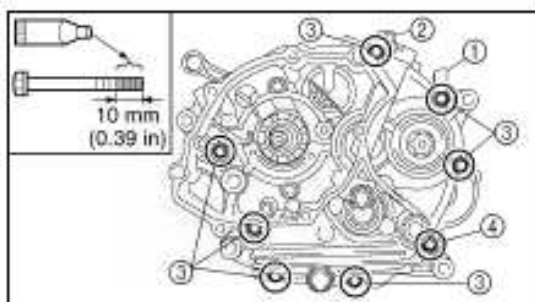

3. Tighten:
- Lead guide ①
 - Clutch cable holder ②
 - Bolt (crankcase) [45 mm (1.8 in)] ③

	10 Nm (1.0 m - kg, 7.2 ft · lb)
--	---------------------------------
 - Bolt (crankcase) [55 mm (2.2 in)] ④

	10 Nm (1.0 m - kg, 7.2 ft · lb)
--	---------------------------------
 - Bolt (crankcase) [30 mm (1.2 in)] ⑤

	10 Nm (1.0 m - kg, 7.2 ft · lb)
--	---------------------------------

4. Check:
- Crankshaft and transmission operation
Unsmooth operation → Repair.

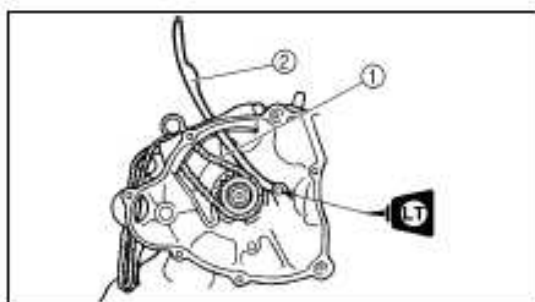

5. Install:
- Timing chain ①
 - Intake timing chain guide ②
 - Bolt (intake timing chain guide)

	10 Nm (1.0 m - kg, 7.2 ft · lb)
--	---------------------------------

TRANSMISSION, SHIFT CAM AND SHIFT FORK

ENG



TRANSMISSION, SHIFT CAM AND SHIFT FORK

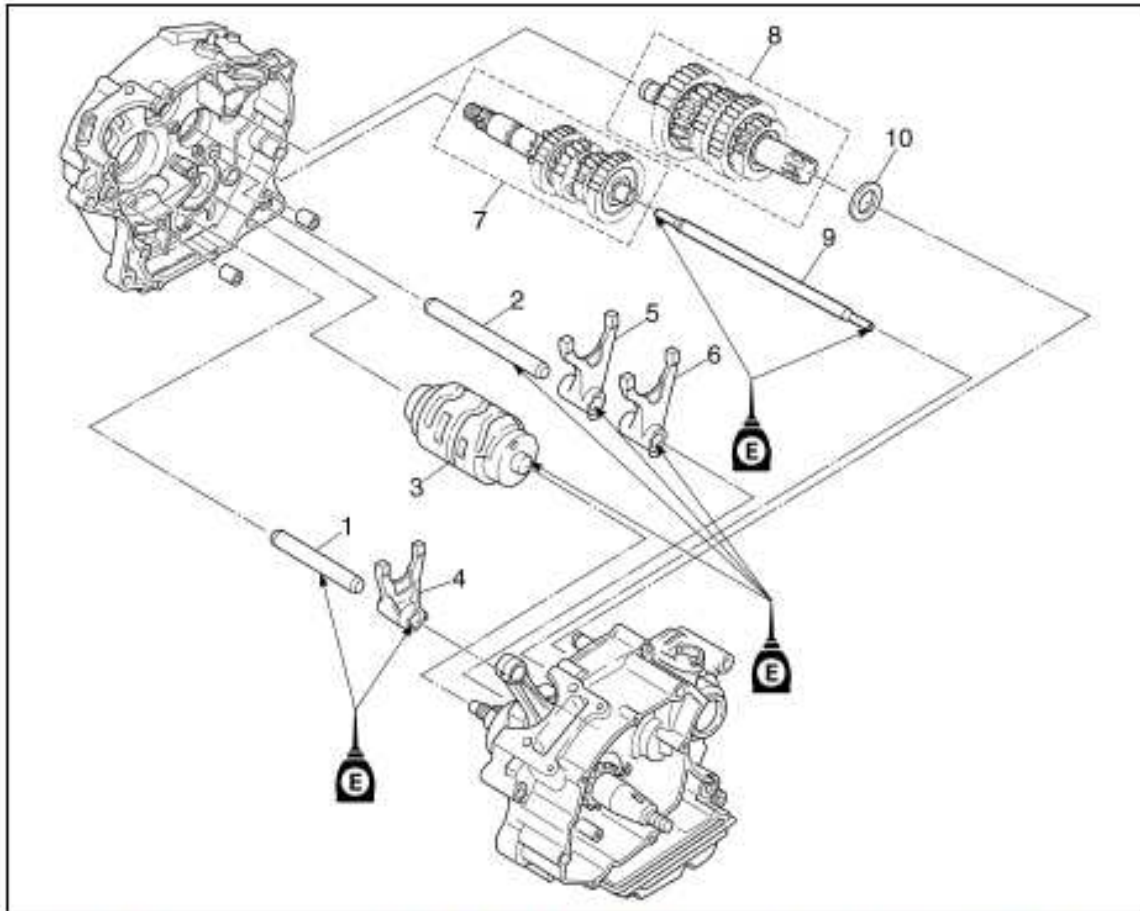

TRANSMISSION, SHIFT CAM AND SHIFT FORK

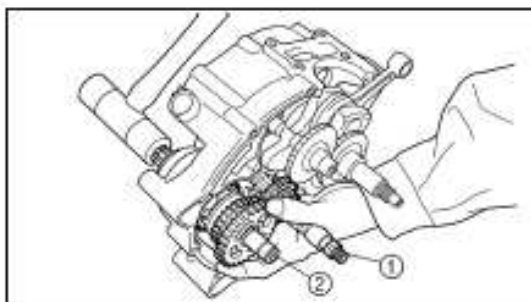

REMOVAL POINTS

Transmission

1. Remove:
 - Main axle ①
 - Drive axle ②

NOTE:

- Tap lightly on the transmission drive axle with a soft hammer to remove.
- Remove assembly carefully. Note the position of each part. Pay particular attention to the location and direction of shift forks.

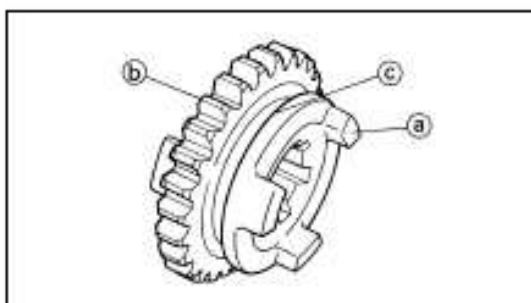

INSPECTION

Gears

1. Inspect:
 - Matching dog ①
 - Gear teeth ②
 - Shift fork groove ③
 Wear/damage → Replace.

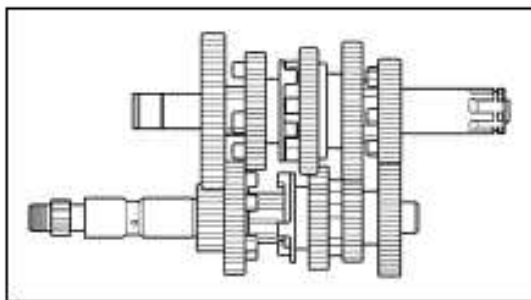

2. Check:
 - Gears movement
 Unsmooth movement → Repair or replace.

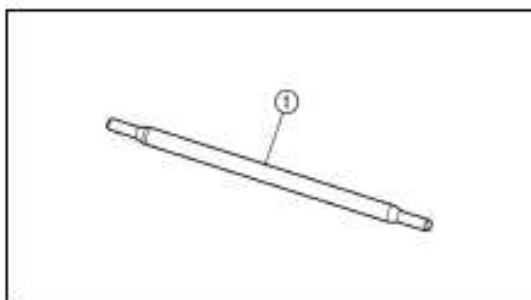

Push rod

1. Inspect:
 - Push rod 2 ①
 Wear/damage/bend → Replace.

TECHNICAL INFORMATION

TRANSMISSION, SHIFT CAM AND SHIFT FORK

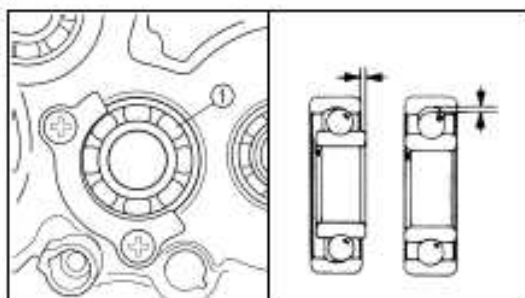

Bearing

1. Inspect:
 - Bearing ①
Rotate inner race with a finger.
Rough spot/seizure → Replace.

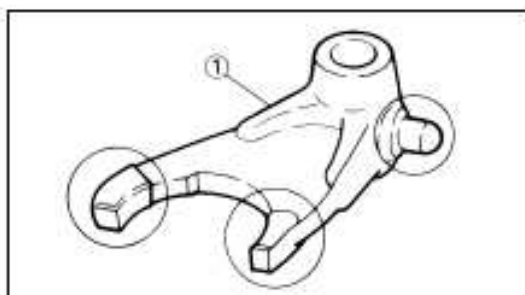

Shift fork and shift cam

1. Inspect:
 - Shift fork ①
Wear/damage/scratches → Replace.

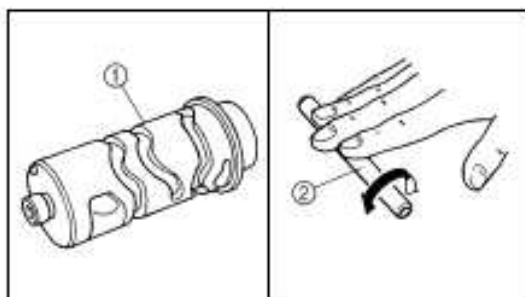

2. Inspect:
 - Shift cam ①
 - Shift fork guide bar ②
Bend/wear/damage → Replace.

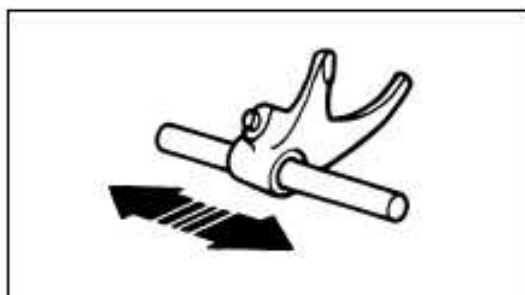

3. Check:
 - Shift fork movement
On its guide bar.
Unsmooth operation → Replace shift
fork and/or guide bar.

NOTE: _____
For a malfunctioning shift fork, replace not only the shift fork itself but the two gears each adjacent to the shift fork.

TRANSMISSION, SHIFT CAM AND SHIFT FORK

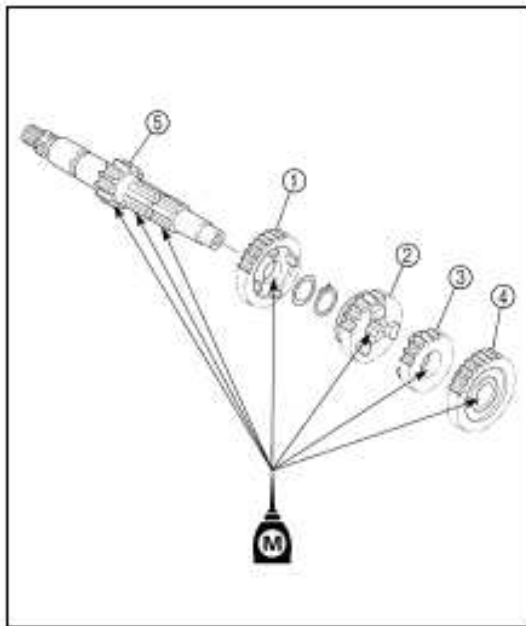

Transmission

1. Install:
 - 4th pinion gear (22T) ①
 - 3rd pinion gear (19T) ②
 - 2nd pinion gear (18T) ③
 - 5th pinion gear (24T) ④
 - On main axle ⑤.

NOTE:

- Apply the molybdenum disulfide oil on the gears' inner circumference.
- Install the 5th pinion gear so that measurement ③ is 83.25 - 83.45 mm (3.278 - 3.285 in).

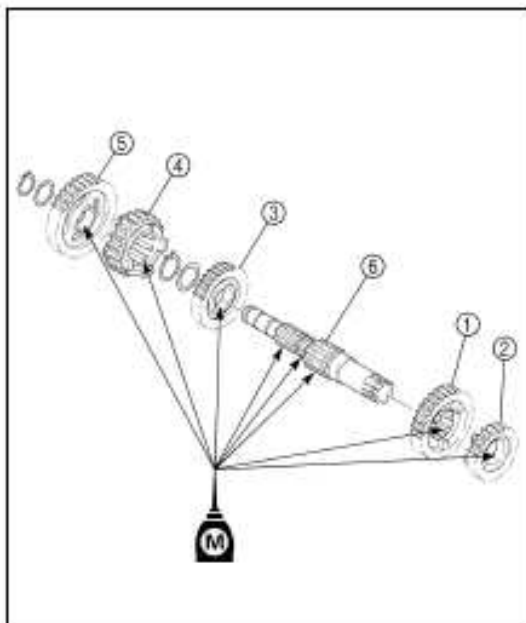
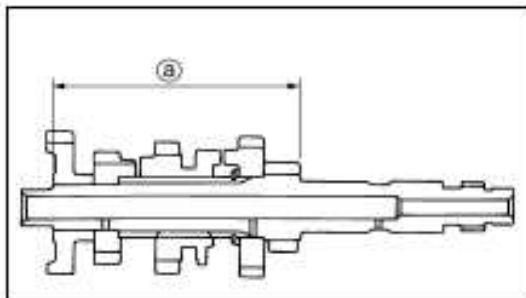

2. Install:
 - 2nd wheel gear (32T) ①
 - 5th wheel gear (21T) ②
 - 3rd wheel gear (25T) ③
 - 4th wheel gear (23T) ④
 - 1st wheel gear (37T) ⑤
 - On drive axle ⑥.

NOTE:

- Apply the molybdenum disulfide oil on the gears' inner circumference.

TECHNICAL INFORMATION

TRANSMISSION, SHIFT CAM AND SHIFT FORK

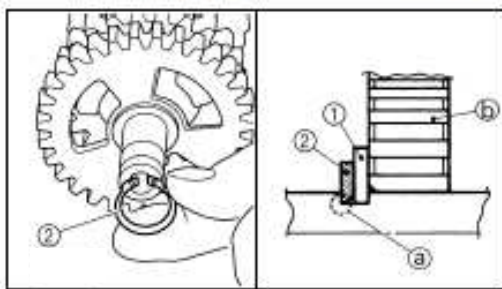

3. Install:
- Plain washer ①
 - Circlip ② **New**

NOTE:

- Be sure the circlip sharp-edged corner ② is positioned opposite side to the plain washer and gear ⑤.
- Be sure the circlip end ③ is positioned at axle spline groove ④.

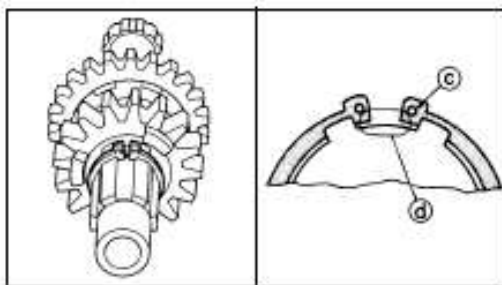

4. Install:
- Push rod 2
On main axle.

NOTE:

Apply the engine oil on the push rod 2.

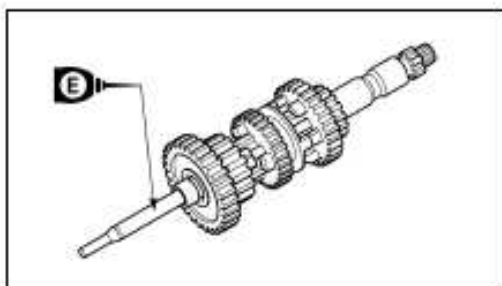

5. Install:
- Washer ①
On drive axle.

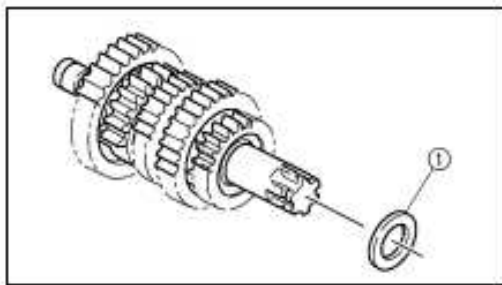

6. Install:
- Main axle
 - Drive axle
Install these in the left crankcase at the same time.

NOTE:

- Apply the lithium soap base grease on the oil seal lip.
- When installing the drive axle into the crankcase, pay careful attention to the crankcase oil seal lip.

TRANSMISSION, SHIFT CAM AND SHIFT FORK

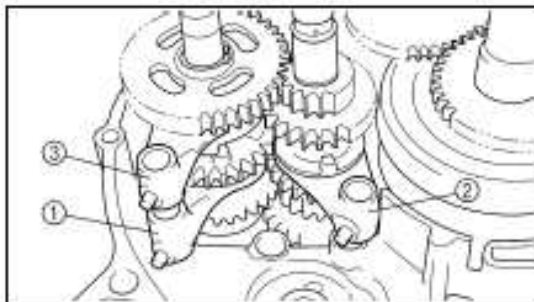

Shift cam and shift fork

1. Install:
 - Shift fork 1 (L) ①
 - Shift fork 2 (C) ②
 - Shift fork 3 (R) ③

NOTE:

- Mesh the shift fork #1 (L) with the 2nd wheel gear and #3 (R) with the 4th wheel gear on the drive axle.
- Mesh the shift fork #2 (C) with the 3rd pinion gear on the main axle.

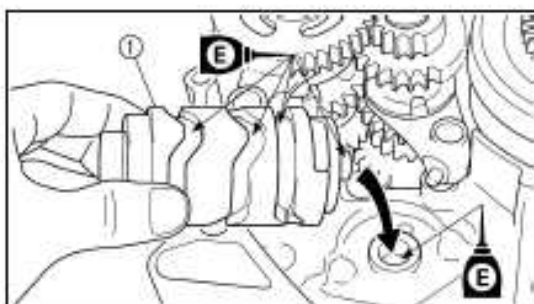

2. Install:
 - Shift cam ①

NOTE:

Apply the engine oil on the shift cam.

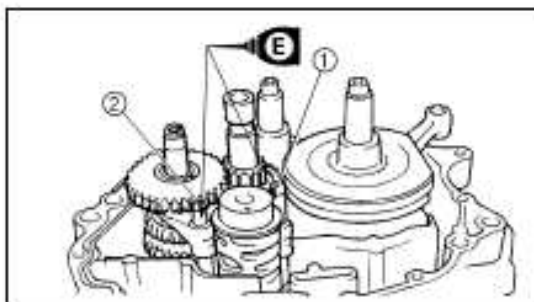

3. Install:
 - Shift fork guide bar 1 (short) ①
 - Shift fork guide bar 2 (long) ②

NOTE:

- Apply the engine oil on the guide bars.
- Be sure the long bar is inserted into the shift forks #1 and #3 and the short one into #2.

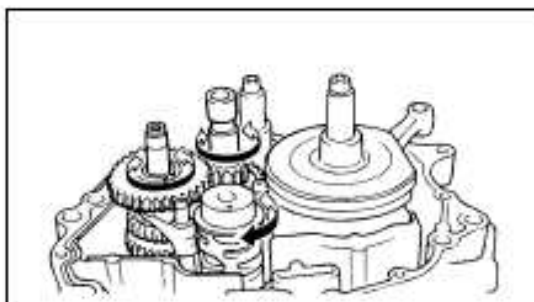

4. Check:
 - Shifter operation
 - Transmission operation
 - Unsmooth operation → Repair.

TECHNICAL INFORMATION

ELECTRICAL COMPONENTS AND WIRING DIAGRAM

N°	DESCRIPCIÓN	N°	DESCRIPCIÓN
1	VELOCIMETER	9	FRONT LIGHT
2	SPEED SENSOR	10	NEUTRAL
3	BRAKE	11	POWER
4	FRONT RIGHT BLINKER	12	HORN
5	FRONT LEFT BLINKER	13	BRAKE
6	FLASHER UNIT	14	REAR LIGHT
7	HANDLEBAR SWITCH	15	REAR RIGHT BLINKER
8	BLINKER SWITCH	16	REAR LEFT BLINKER

COLOR CODE	
YE	YELLOW/AMILLO/AMARILLO
RD	RED/ROJO/ROJO
BK	BLACK/NEGRO/NEGRO
BU	BLUE/AZUL/AZUL
BR	BROWN/MARRON/MARRON
GN	GREEN/VERDE/VERDE
VI	VIOLET/VIOLETA/VIOLETA
WH	WHITE/BLANCO/BLANCO
GY	GREY/GRIS/GRIS
PK	PINK/ROSA/ROSA
OR	ORANGE/ANARANJA/ANARANJA

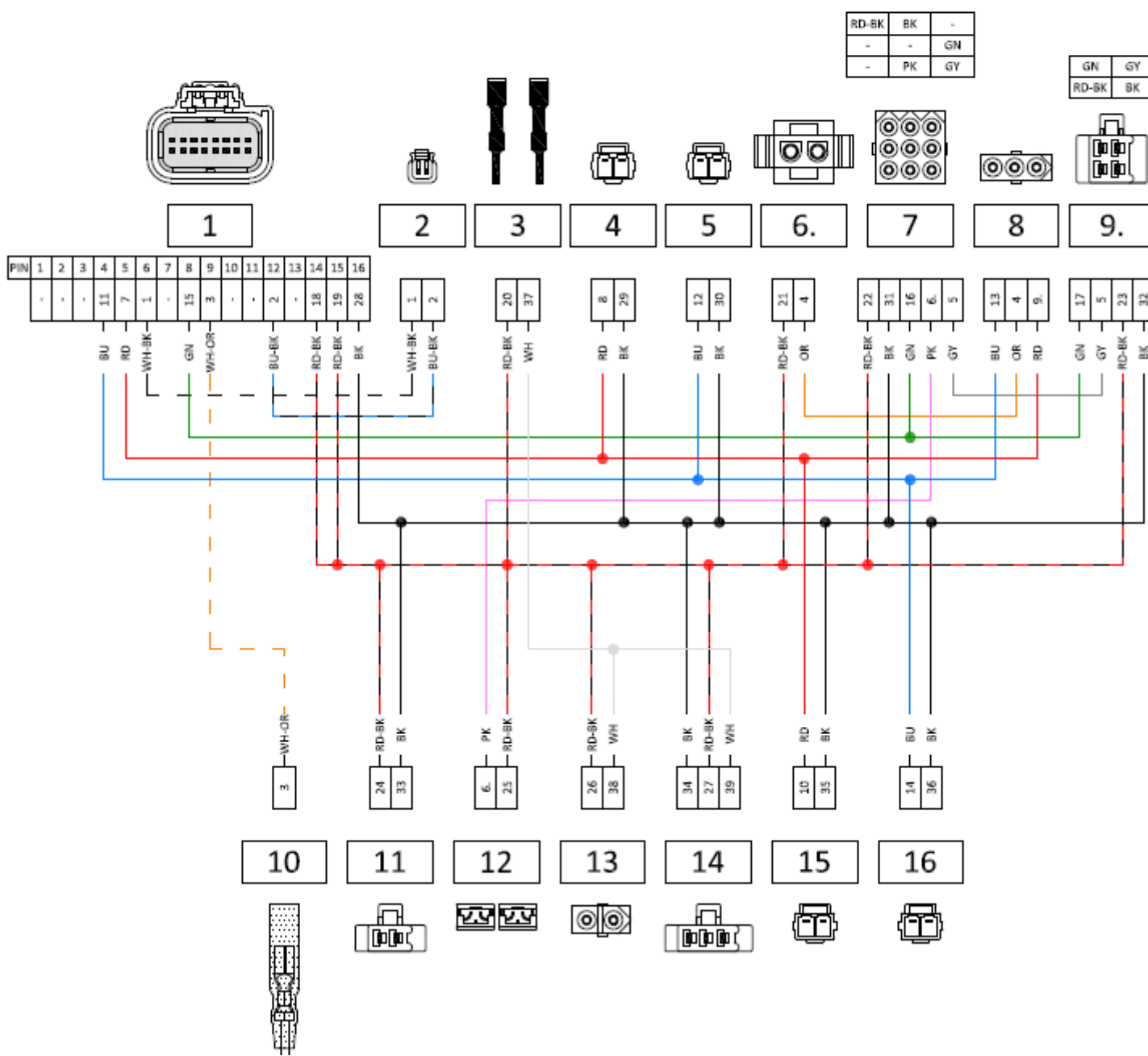

TECHNICAL INFORMATION

ELECTRICAL COMPONENTS AND WIRING DIAGRAM

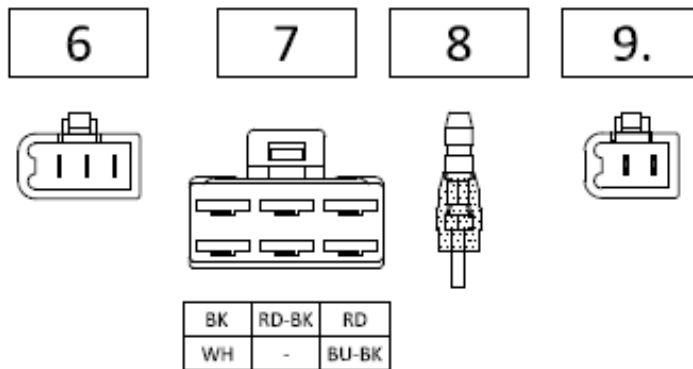
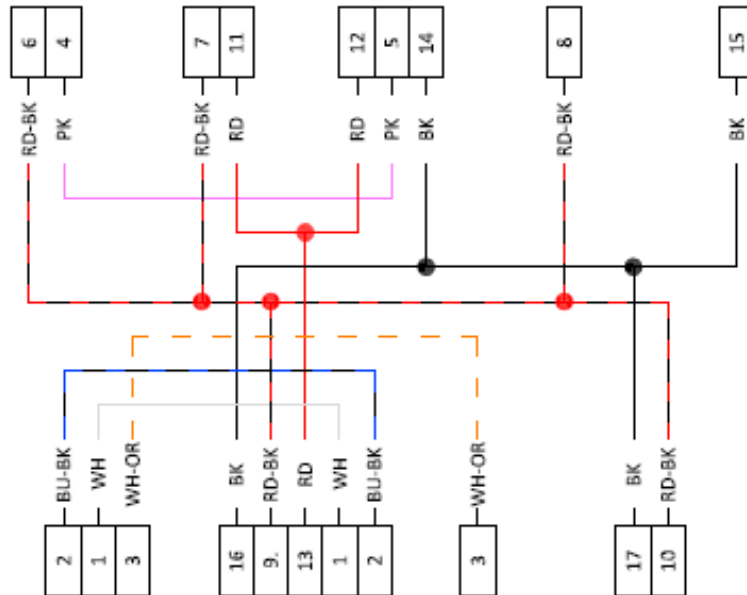
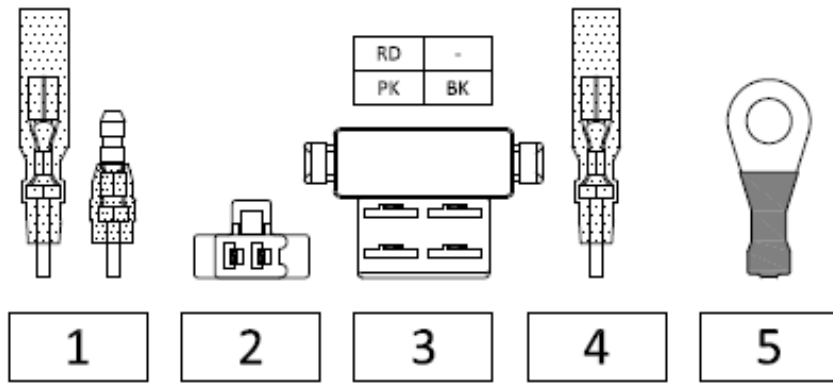

COLOR CODE	
YE	YELLOW
RD	RED
BK	BLACK
BU	BLUE
BR	BROWN
GN	GREEN
VI	VIOLET
WH	WHITE
GY	GREY
PK	PINK
OR	ORANGE

TECHNICAL INFORMATION

ELECTRICAL COMPONENTS AND WIRING DIAGRAM

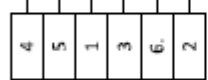
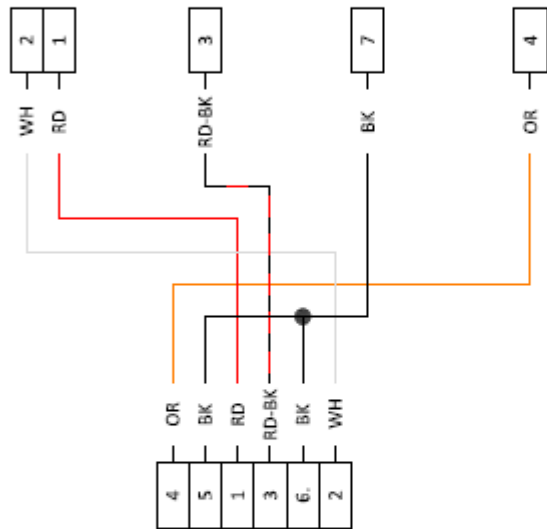
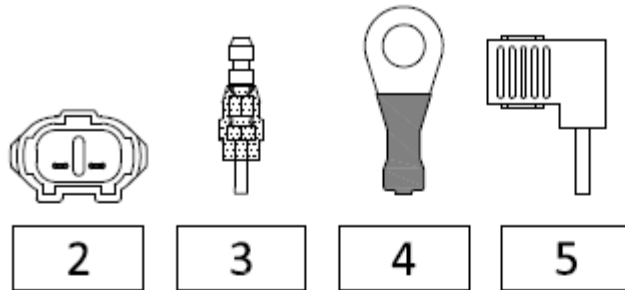

1



OR	BK	RD
RD-BK	BK	WH

COLOR CODE	
YE	YELLOW
RD	RED
BK	BLACK
BU	BLUE
BR	BROWN
GN	GREEN
VI	VIOLET
WH	WHITE
GY	GREY
PK	PINK
OR	ORANGE

SHERCO
Motorcycles

www.sherco.com

BRAKTEC

GALFER

MINERVA OIL

REIGER
SPORTSWEAR